

Module **B8**

Trigonometry

Introduction

In the previous modules we have looked at functions – both straight line and curved (parabolic, exponential, logarithmic). There are other families of functions that form patterns besides these. One of these new families of functions is called the trigonometric functions which are used in diverse fields of study such as electricity, music and oceanography. If you go on to study science, mathematics or engineering you will use these new functions.

The development of trigonometry has a long history. Like most things mathematical it is embedded in the practical, in this case surveying, astronomy or navigation. While it was used as early as Babylonian times, and trigonometric tables were used in a form in Greek times, it wasn't until the 15th century that trigonometry was related to other areas of mathematics, and later, came to be intricately related to all branches of mathematics.

You should have some knowledge of trigonometry from your previous studies (such as *Mathematics Tertiary Preparation Level A*). This module will draw on some of this knowledge, and relate it to your knowledge of algebra and functions learnt in previous modules.

On successful completion of this module you should be able to:

- solve real world problems using trigonometric ratios
- demonstrate an understanding of and use the sine, cosine and tangent of any angle and its inverse
- solve some trigonometric equations
- describe and sketch the trigonometric functions of sine, cosine and tangent.

8.1 The sine story

From your previous studies you should have read about sine ratios in triangles (pronounced sine – same as sign, the abbreviation sin is also pronounced sine). The sine story is an old one. While the concept was known by the Greeks, the word and concept of the ratio as a function of the angle was first used in a Hindu text in about the year 510 and the word *sine* was first used early in the 17th century.

Let's revisit the sine ratio before moving on to the sine function.

8.1.1 The sine ratio

What if you wanted to build a seesaw for a playground. It must be safe (not too steep) but exciting enough for children. It would be useful for you to make a model of this problem. Find different lengths of wood for the seesaw and the pivot (perhaps rulers, pencils and erasers on your desk will do!). Make sure the pivot is in the centre. Keep the model in front of you as you go through these exercises.

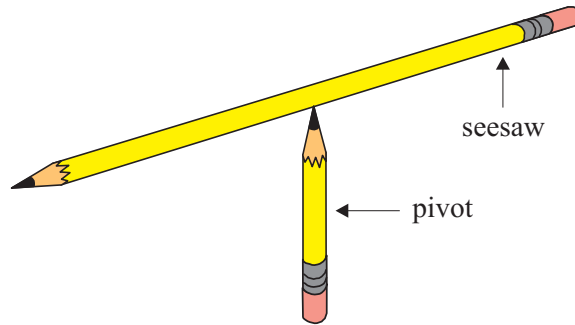

Recall that variables are those elements of a problem that can vary or change. Write down any variables you think would be involved in the seesaw problem.

Here are some variables you may have thought of:

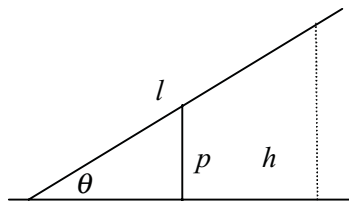

- The length of the seesaw (call it l).
- The length of the pivot (call it p).
- The height of the seesaw above the ground (call it h) – do you agree it is twice the length of the pivot ($h = 2p$)?
- The angle the seesaw makes with the ground (call it θ – we usually name angles with Greek letters – this symbol is called *theta*). Theta is also linked to the other two variables. Notice in your model that if you have either a longer seesaw or higher pivot the angle will change.

Note: In this module we will be using symbols α (alpha), β (beta), ϕ (phi), γ (gamma) and θ (*theta*) as variables representing angles.

Can you notice anything about the relationship between the variables in the seesaw? For example, you could say that the height of the seesaw is a function of the angle the seesaw makes with the ground ($h = f(\theta)$); it could also be seen as a function of the length of the seesaw, ($h = f(l)$). With the help of trigonometry, we can find the exact relationship between these variables. But first let's have a short review of the basic sine ratio.

Let's do some scale drawings. Say you wanted the seesaw to make the angle of 40° to the ground. Draw some possibilities using a protractor. Here are a couple. You could draw some different ones.

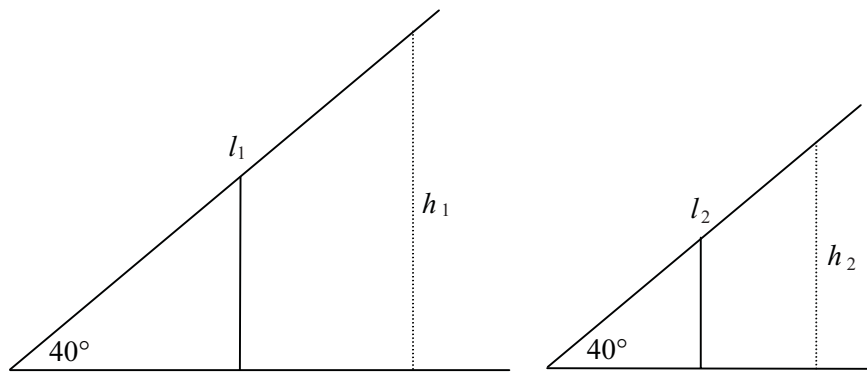

Measure the height of the seesaw above the ground and the length of the seesaw in each case. Now divide the height by the length. What do you notice?

You should have found it to be about 0.64 in each case.

So while the angle remains the same, the ratio of the height (h) to the length of the seesaw (l) is the same in each case no matter how long the seesaw. This ratio is called the **sine ratio**. In this case the sine of forty degrees is approximately equal to point six four.

We write $\sin 40^\circ \approx 0.64$.

If we changed the angle, another constant ratio would occur. An angle of 30° gives a $\sin 30^\circ = 0.50$. You would either say sine thirty degrees equals 0.50 or the sine of thirty degrees equals 0.50.

Remember

- we must be in a **right** angled triangle and
- the sine ratio is the ratio of the **opposite** side to the **hypotenuse**.

In a right angled triangle, sine of an angle = $\frac{\text{opposite side}}{\text{hypotenuse}}$

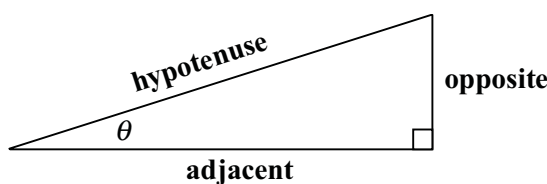

8.4 TPP7182 – Mathematics tertiary preparation level B

We can find the sine ratio of any angle by using our calculator.

Find the sine of the following angles on your calculator (correct to 4 decimal places if necessary). Before you start, make sure your calculator is in degree mode (a small DEG should appear on the top of the display).

θ	0°	12°	24°	30°	35°	48°	60°	70°	90°
$\sin \theta^\circ$									

Look at the solutions for a few moments. Write down any changes you see in the sine of the angles. Describe these changes.

θ	0°	12°	24°	30°	35°	48°	60°	70°	90°
$\sin \theta^\circ$	0	0.2079	0.4067	0.5	0.5736	0.7431	0.8660	0.9397	1

Hopefully you would have said some of these things about the sine ratios:

- they get larger as the angle gets larger; Point 1
- they are between and including 0 and 1; Point 2
- some of them are exact, others are approximate; Point 3
- they are not directly proportional e.g. the sine of 30° is not half the sine of 60° ; Point 4
- the difference between the sine of 12° and 24° is quite large (about 0.2), but the difference between 70° and 90° is quite small (about 0.06). Point 5

Go back and have a look at the model of the seesaw. We can see why the first two are true.

Point 1: Each time look at the ratio of the **opposite** side (height of the seesaw) to the **hypotenuse** (length of the seesaw). If you keep the hypotenuse a constant length (say at 1 metre) then as the angle gets bigger, the opposite side gets bigger and bigger – closer to the length of the hypotenuse. When it gets to be the same size as the hypotenuse, the angle is 90° (the seesaw is upright!). So as the angle gets larger, the ratio gets larger. The diagram below may help to show this more clearly. Remember your pivot is going to have to lengthen as well.

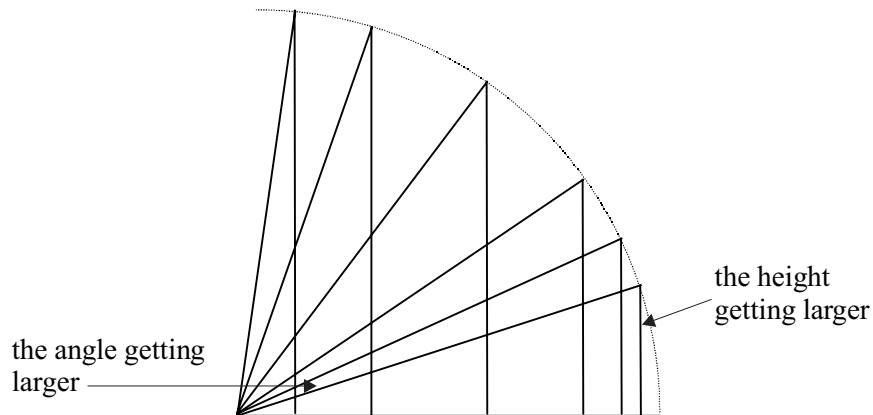

Notice the tops of the triangles makes an arc of a circle whose radius is the seesaw length. Remember this. We will come back to this point later.

- Point 2: The sine ratio can never be greater than 1 since it's the opposite side over the hypotenuse, and the hypotenuse is always the longest side in the triangle.
- Point 3: The only ratios here that are exact are 0° , 30° and 90° . All others are approximate. You may wonder how accurate to be in trigonometrical examples. Often we take it to 4 decimal places – but really be sensible – it depends on the situation. When measuring precise angles such as when erecting buildings or constructing intricate instruments, precision is important. When searching for boats in the ocean, if you are out by 10 metres it may not matter.
- Point 4: Why the ratio is not proportional is more difficult to see. If you graph the relationship between the size of the angle and the sine ratio, you will see there is a regular relationship (some sort of repeated pattern) – but it's not a linear relationship. We will graph this in the next section.
- Point 5: This gives a clue to the nature of the relationship between the sine and the angle. This is more easily seen when we graph the relationship in the next section.

The above five points are important concepts regarding the sine ratio. In the examples below you will use the sine ratio to solve problems, so you should keep these 5 points in mind when working on these activities.

Some further information that might help is that angles can often be of two types: **angles of elevation** and **angles of depression**.

The diagrams below will help to explain the meaning of these terms.

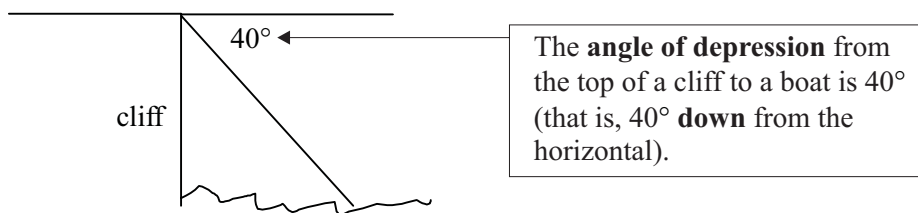
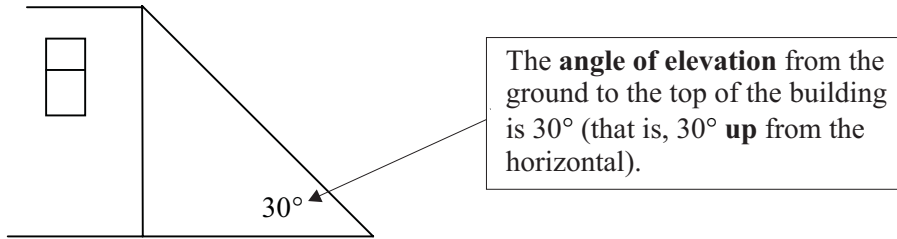

Example

A child 1.2 metres tall flies a kite at an angle of 35° to the horizontal (i.e. **the angle of elevation**). If the child used 138 metres of string, how far is the kite from the ground (assume the string is straight).

First we should draw a diagram and label the knowns and unknowns.

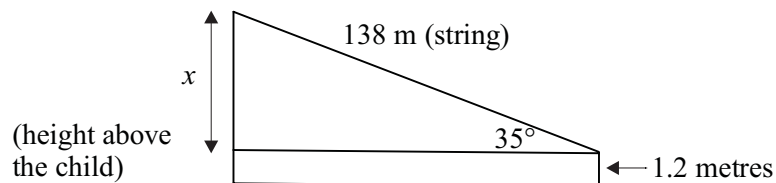

$$\sin 35^\circ = \frac{\text{opposite}}{\text{hypotenuse}}$$

$$\sin 35^\circ = \frac{x}{138}$$

$$138 \times \sin 35^\circ = x$$

$$x = 79.1535$$

The height of the kite above the ground is $(79.15 + 1.2) = 80.35$ metres (correct to 2 decimal places).

Example

In the example above, if the wind blew the kite so it is now 70° to the horizontal, will the kite be twice as far from the ground?

Since the sine ratios are not proportional, it will not be twice as high. You can check this.

$$\begin{aligned}\sin 70^\circ &= \frac{x}{138} \\ 138 \times \sin 70^\circ &= x \\ x &= 129.6776\end{aligned}$$

Activity 8.1

1. A missile was fired at an angle of elevation of 25° . What is its height after it has travelled 500 m (assuming it is travelling in a straight line)?
2. Jack West is in a boat. He sees another boat in front of him and talks to him over the radio. The other boat says 'I am exactly 20 km east of the lighthouse'. Jack then moves his boat so he is directly south of the other boat. His mate Jill, measures the angle between the other boat and the lighthouse and finds it to be 25° . How far are Jack and Jill from the lighthouse?
3. From a spacecraft approaching the planet Mathematica, the planet subtends an angle of 5° . Knowing that the radius of the planet Mathematica is about 4200 km, calculate the shortest distance from the spacecraft to the planet.

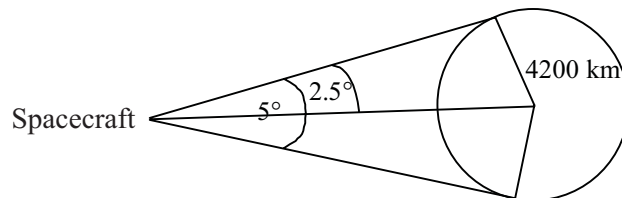

4. A pilot is in level flight at 1200 m altitude. The closest point on the ground he can see over the nose of the aeroplane is at an angle of depression of 20° . (This is called the cockpit cutoff angle.) How far is the plane from this point?
5. In question 2, a student, Chris Tryalot sent in the following solutions. Imagine you are a teacher. Comment on the four attempts.

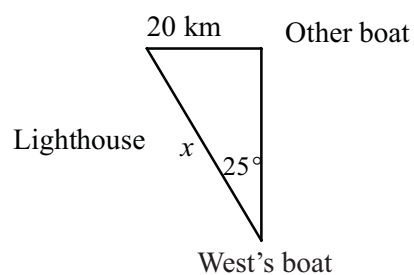
Attempt 1

$$\sin 25^\circ = \frac{\text{opp}}{\text{hyp}}$$

$$= \frac{20}{x}$$

$$0.4226 \times 20 = x$$

$$8.45 \approx x$$

So the lighthouse is 8.45 km north west of the West's boat

Attempt 2

$$47.324032$$

Attempt 3

$$\sin 25 = \frac{20}{x}$$

$$x = \frac{20}{\sin 25}$$

$$= \frac{4}{\sin 5}$$

$$\approx 46 \text{ km}$$

Attempt 4

$$x = \frac{20}{\sin 25}$$

$$= -151 \text{ km}$$

I must have made a mistake here somewhere, since the number is too big and what does the negative mean??

8.1.2 The sine function

In the previous section, we said that sine ratios are not directly proportional and we saw this in the kite example. We also saw that the sine ratio changes quite quickly at first then more slowly. Let’s have a closer look at the relationship between the angle and its sine.

Graph the points below on your own graph paper (you may use a graphing package – but at this stage it would be of greater benefit if you did this by hand and check it on a graphing package or a graphics calculator.). Use the graph paper in landscape (i.e. the horizontal being the longer side) and the horizontal axis in the middle of the page. Put the vertical axis 2 cm from the left hand side. Use a scale of 1 cm represents 20° on the horizontal and 1 cm represents 0.2 on the vertical axis. You will be using this graph again, so spend some time getting it correct and neat!

θ	0°	12°	24°	30°	35°	48°	60°	70°	90°
$\sin \theta^\circ$	0	0.208	0.407	0.5	0.574	0.743	0.866	0.940	1

What are the variables on the axes? Can you name the function to which this graph is referring? What are the domain and range?

- The variable on the horizontal axis is the angle θ (so the domain here is 0° to 90°). You should label the axis itself as θ , not x .
- The variable on the vertical axis is the ratio itself (so the range is 0 to 1).
- The equation to this curve is: $f(\theta) = \sin \theta$. This is called the sine function.
- Can you see the curve rises relatively steeply at first then more slowly as the degrees get closer to 90°. This is an important concept in areas such as electricity. If you are looking at the magnitude of current going through a wire over time, it is not even but varies like the sine curve.

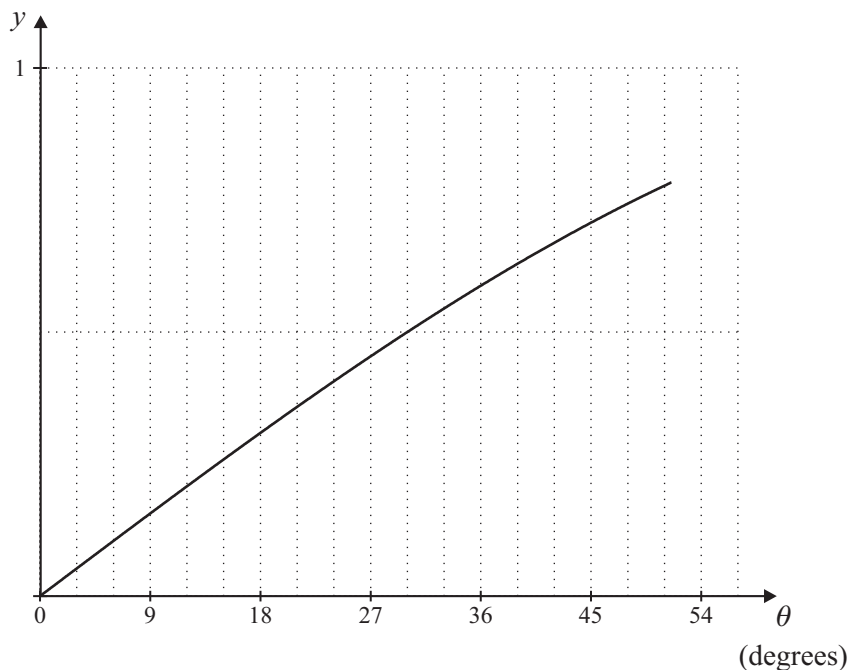

If you look at this in terms of the seesaw again, the values on the θ -axis are the angles that the seesaw makes with the ground. If we make the seesaw length 1 metre, then the values on the $f(\theta)$ -axis are the heights the seesaw is above ground.

Remember

$$\sin \theta = \frac{\text{opposite}}{\text{hypotenuse}}$$

$$= \frac{\text{height}}{\text{length}}$$

$$\sin \theta = \frac{h}{l} \qquad \begin{array}{l} h = \text{height above ground in m} \\ l = \text{length of seesaw in m} \end{array}$$

$$h = l \times \sin \theta$$

so when the length of the seesaw is 1 metre,

$$h = \sin \theta$$

Remember this. It is an important concept that we will develop further.

The idea that the sine ratio could be treated like an equation was first published by Francis Vieta in the 15th century and developed by Rene Descartes. The sine curve can actually be plotted as an endless wavy line – the exact graphic equivalent to the alternating electric current plotted against time. Joseph Fourier later discovered in the 18th century that all sound waves also followed this pattern.

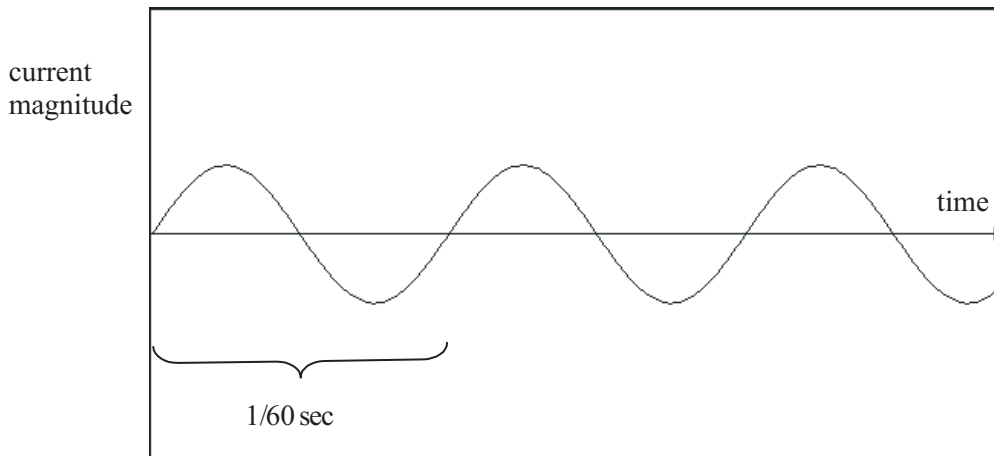

Previously we looked at the sine ratio of angles less than 90° , but if we want to extend our idea to include other angles, we have to think of something different. In the seesaw problem we could flip over the seesaw – not very healthy for children! But we now have angles greater than 90° .

So instead of thinking of an angle in a triangle, think of the definition of an angle as the amount of turning one line has to do to get into the position of another line. In fact the word angle comes from the Latin *angulus* meaning a little bending – like the word ankle.

Let's forget about a seesaw and think, instead, of the hands of a clock. This is a strange backwards clock! This clock has one hand always on the 3 and the other turning in an anticlockwise direction. With both hands at three, the angle is zero degrees. When the other hand is on the 12, the angle is 90° .

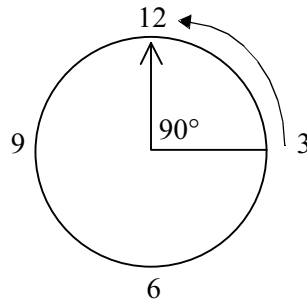

If we superimpose the coordinate system onto the clock with the centre of the clock as the origin, then we can position the angle according to a point P with the coordinates (x, y) .

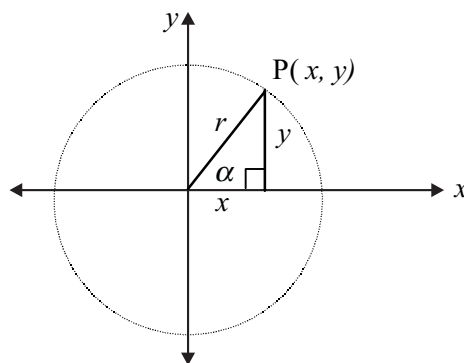

From the triangle in the circle, $\sin \alpha = \frac{y}{r}$ where y is the y -coordinate of P and r is the length of the radius.

Example

If the radius is 1 unit, what is the y -coordinate of P in the diagram below?

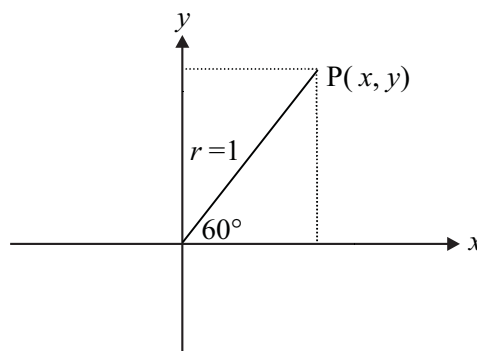

$$\sin 60^\circ = \frac{y}{r}$$

If $r = 1$ and $\sin 60^\circ \approx 0.8660$

then $y \approx 0.8660$

Activity 8.2

1. Find the value of y in the following diagrams.

(a)

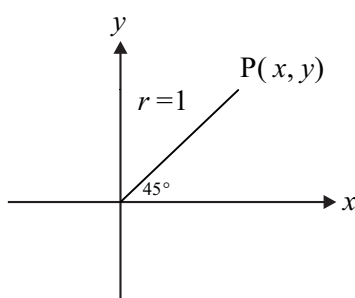

(b)

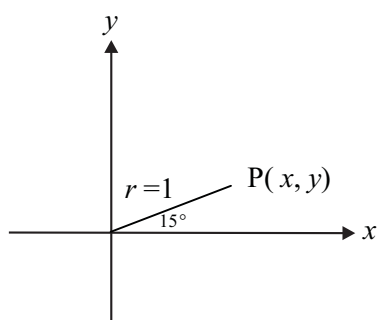

(c)

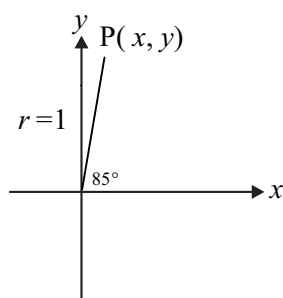

(d)

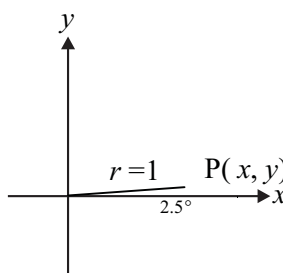

Now let's look at the angles greater than 90° in the diagrams below.

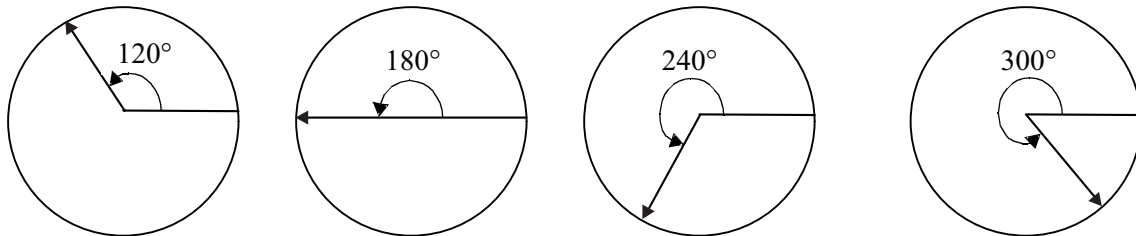

Again, superimpose the coordinate system on the circles. Now you can see that P lies in different **quadrants**.

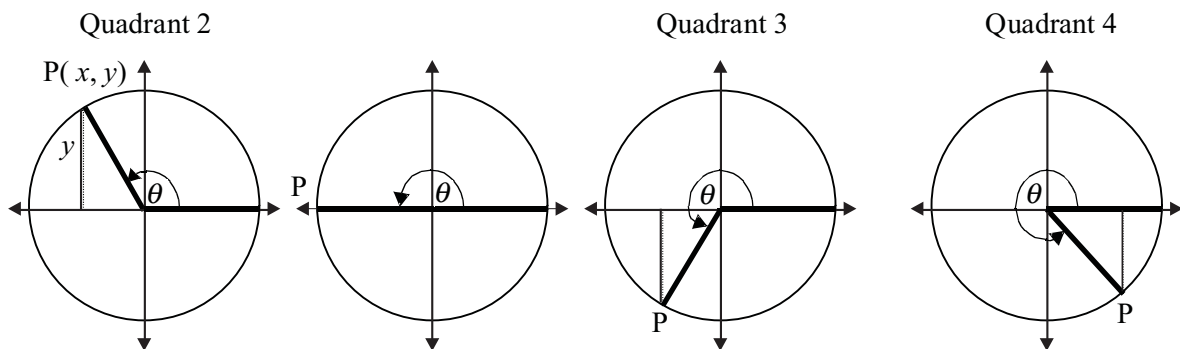

$\theta = 120^\circ$	$\theta = 180^\circ$	$\theta = 240^\circ$	$\theta = 300^\circ$
$\sin \theta \approx 0.8660$	$\sin \theta = 0$	$\sin \theta \approx -0.8660$	$\sin \theta \approx -0.8660$

If you look at P in each quadrant then the value of y can be positive or negative, but the value of r will always be positive since it's a length. Note the following:

- 120° is in the 2nd quadrant. So the y -coordinate of P will be 0.8660 (the same as $\sin 60^\circ$).
- 240° is in the 3rd quadrant. Notice the y -coordinate is negative so the sine is negative.
- 300° is in the 4th quadrant it's also negative. (same as $-\sin 60^\circ$)
- The sine of 240° and the sine of 300° are the same since they have the same y -coordinate.

You can see that the sine of angles between 90° and 180° are still positive, but the angles between 180° and 360° are negative. Can you see why this would be the case?

When the angles are between 180° and 360° we are measuring the opposite side as going downwards and would be negative. In each case the hypotenuse is positive. Check these answers on your calculator.

Activity 8.3

1. The following will be a useful summary. Try and think of a useful way to memorise this information. We will revisit this once we have looked at the other trigonometric ratios.

(a)

θ	$\sin \theta$
0°	
90°	
180°	
270°	
360°	

(b) Sine is positive in the _____ quadrants.

Sine is negative in the _____ quadrants.

2. Determine the quadrant in which the following angles occur and whether the sine of the angles will be positive or negative. Then, on your calculator find the sine of these angles:

α	Quadrant	Sign (\pm)	$\sin \alpha$
250°	3rd	-	0.9397
125°			
160°			
189°			
235°			
280°			
320°			
350°			
390°			

Example

Find an angle with the same sine as 250° .

Consider the angle 250°

- Place the angle 250° in a unit circle (a circle with radius 1 unit) and mark the point P on the circle.
- Find the y -coordinate of P.
- Find another point Q on the circle, with the same y -coordinate.
- What is the angle that places Q in this position?

To place the angle 250° in the unit circle draw a diagram as below.

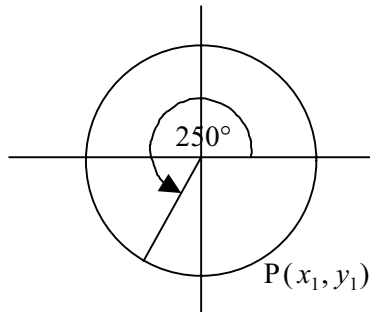

The y -coordinate of P is

$$y = \sin(250^\circ) = -0.9397$$

The point Q will lie in the 4th quadrant, as it has the same y -coordinate as P.

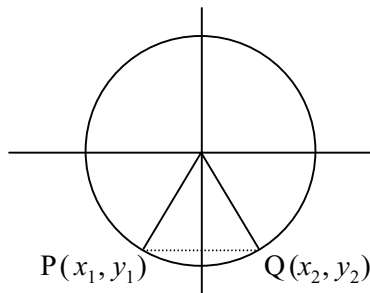

Notice the equivalent angles that are formed (in the diagram below α and β).

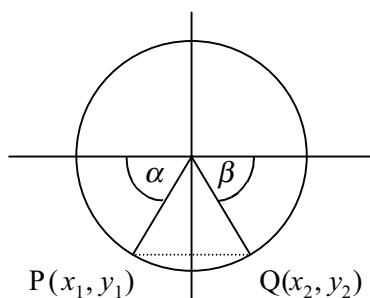

Since the original angle was 250° , the angle α will be $250^\circ - 180^\circ = 70^\circ$. Angle β will also be 70° . So the angle with the same sine as 250° will be $360^\circ - 70^\circ = 290^\circ$. Check this on the calculator. $\sin 290^\circ \approx -0.9397$.

Activity 8.4

Find angles with the same sine as (a) 310° and (b) 140° by following these steps.

Consider the angles (a) 310° and (b) 140°

- Place the angle in a unit circle and mark the point P on the circle.
- Find the y -coordinate of P.
- Find another point Q on the circle with the same y -coordinate.
- What is the angle that places Q in this position?

Imagine what would happen if you go beyond 360° – if you keep turning the other hand of the clock. You can have degrees more than 360° – but they would look like the 0° to 360° range. So $\sin 400^\circ = \sin (360^\circ + 40^\circ) = \sin 40^\circ \approx 0.6428$. Because 40° and 400° have the same P coordinates, we call them **co-terminal** angles.

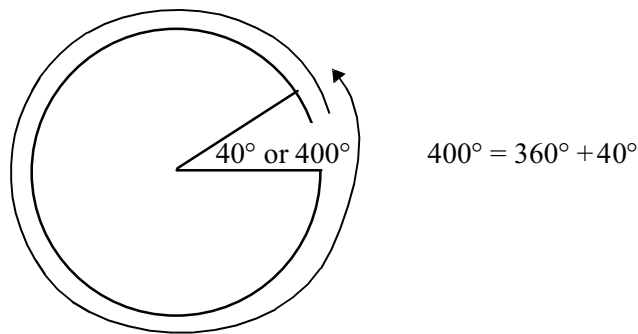

Activity 8.5

- For the angles below find their sine, and find other co-terminal angles.

α	$\sin \alpha$	Angle as multiple of 360°	Other co-terminal angles
920°	-0.3420	$360^\circ \times 2 + 200^\circ$	$200^\circ, 560^\circ, 1280^\circ$
520°			
600°			
650°			
800°			

- Plot the points below on the graph you drew earlier. Remember a sine curve was described as a continuous wavy line. Now what do you notice?

θ	125°	160°	189°	235°	280°	320°	350°	390°	400°	460°
$\sin \theta^\circ$	0.82	0.34	-0.16	-0.82	-0.98	-0.64	-0.17	0.5	0.64	0.98

Of course there is no reason to restrict the domain; it can go from zero to positive infinity ($0 < \theta < \infty$). Try this on a graphing package. It will look something like this for a domain from 0° to 1000° .

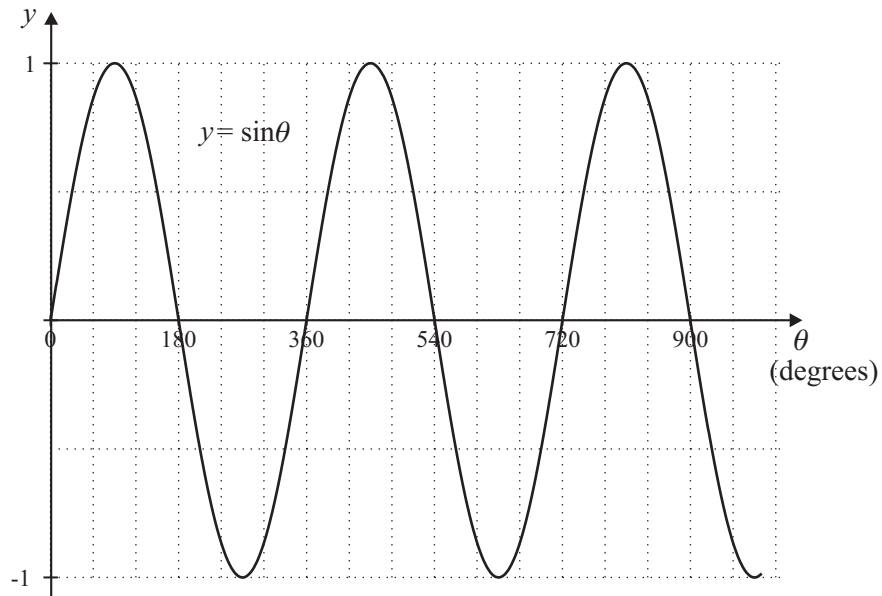

Can this function have an even bigger domain – can it go from 0° to negative infinity? We can define -20° as going in a clockwise direction. So $\sin(-20^\circ)$ will be the same as $\sin 340^\circ$.

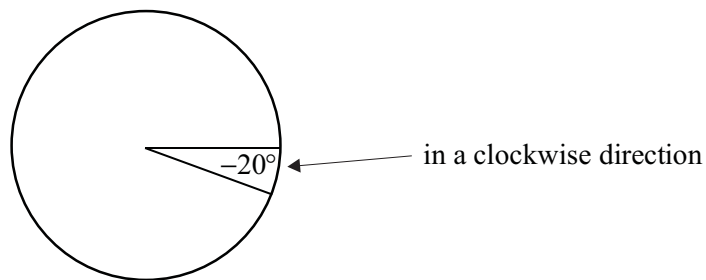

On a graph, the sine of negative angles will continue in the negative direction along the θ -axis.

On some graph paper sketch the graph of $y = \sin \beta$ from -360° to 360° . You will need to spend some time thinking about the scale on the β axis. It should look something like the one below.

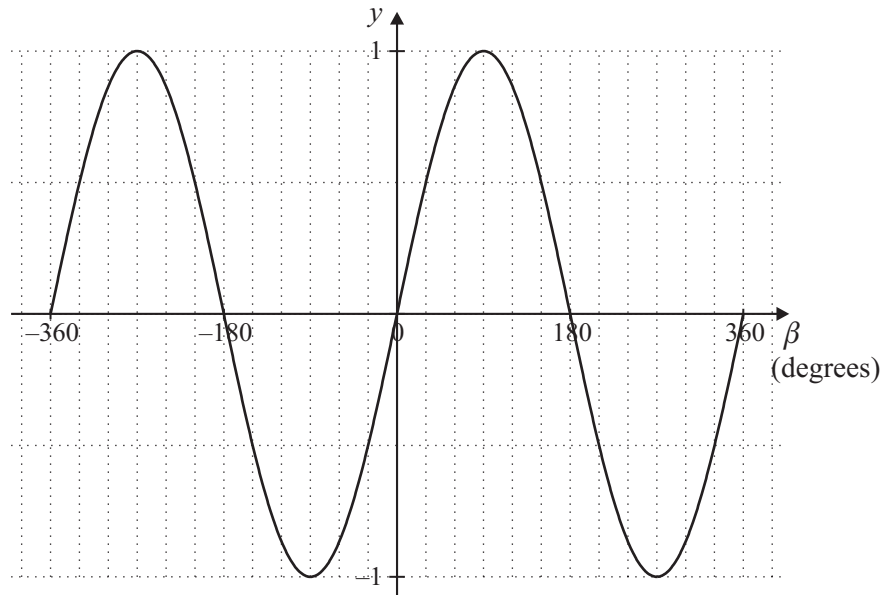

8.1.3 The inverse of the sine function

Practice reading **your** graph from activity 8.5. Pick a point on the graph, $\theta = 24^\circ$. You see that $y \approx 0.4$. This means that an angle of 24° has a sine ratio of about 0.4.

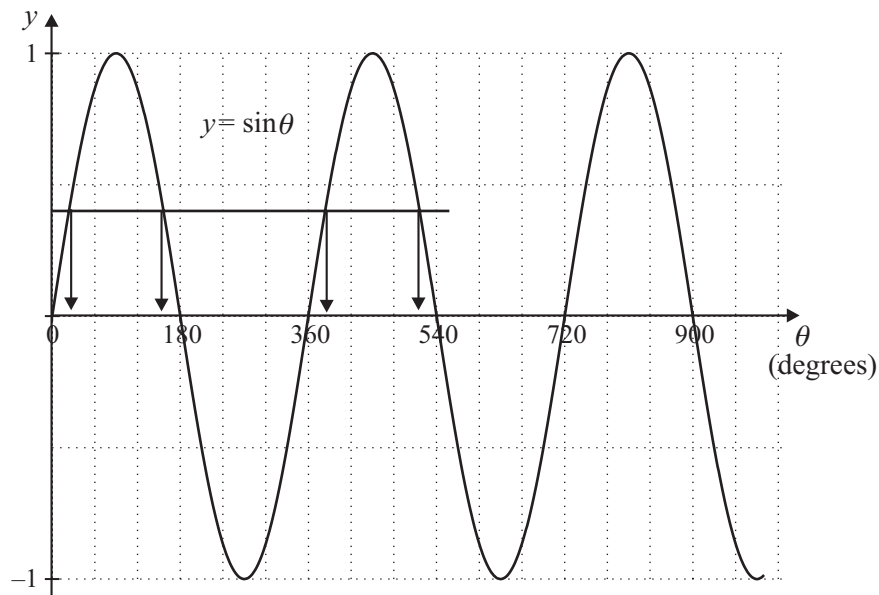

If we read it the other way. A sine ratio of 0.4 would have an angle of about 24° . But if you kept on reading from left to right – there are a lot more angles that have this same sine ratio. Can you see that 0.4 also gives θ values at 156° and 384° . There would be an infinite number of angles (think of the clock going round and round). How does this fit into your idea of a function? Can you see that each element of θ is associated with one element of y or $f(\theta)$. But

if we do it the other way around, each element of $f(\theta)$ is associated with many elements of θ . This means that $f(\theta) = \sin \theta$ is a function but its inverse is not a function if the domain is unrestricted. This is an important concept that will be developed as you do more work on functions and inverses in later courses.

You can find the size of an angle given its sine ratio by reading the graph. Try a few of these yourself by reading your graph.

Activity 8.6

1. Using your graph, find angles that have the following sines:
 - (a) 0.23
 - (b) 0.98
 - (c) -0.15
 - (d) -0.55

You can find these angles more accurately on your calculator. If an angle had a sine of 0.4, what could the angle be? While there are an infinite number of answers here, from reading the graph, we found 24° , 156° , and 384° . Now on your calculator look at the sine button. There should be a \sin^{-1} button usually above the sin button. Press 0.4 then the \sin^{-1} button this should give you the exact answer (correct to 8 or 9 decimal places) of 23.57817848. This angle is in the first quadrant. Remember there are more angles that have this sine. You must find them yourself. You have already attempted this in activities 8.4 and 8.5. Here are some steps that may be useful for you. You do not need to do step 2, but it allows you to see the relationship between the sine and it's inverse, and is a good estimation tool.

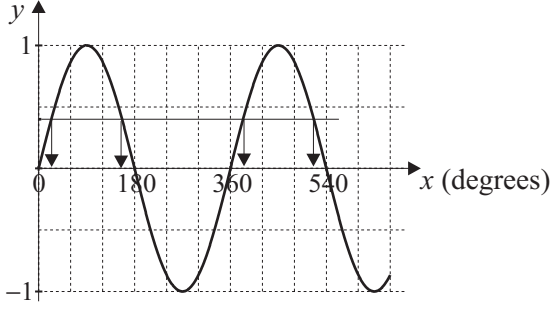
<p>Step 1 Find the angle in the first quadrant using a calculator</p>	$\sin^{-1} 0.4 = 23.578$
<p>Step 2 Draw a quick sketch of the sine curve to see which other angles give this same sine value.</p>	

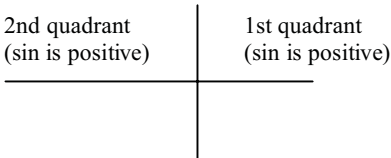
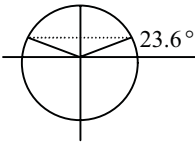
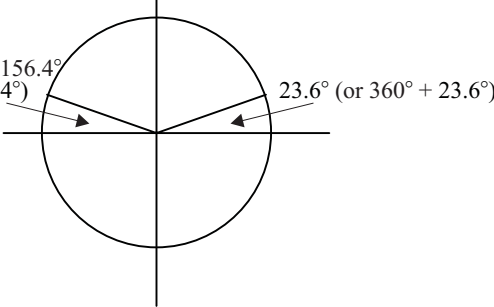
<p>Step 3 Decide which quadrant the other angle is in.</p>	
<p>Step 4 Sketch a circle; put in the angle from step 1. Locate the angle in the other quadrant. (y-coordinates will be the same).</p>	
<p>Step 5 Find the size of the angle in this other quadrant.</p>	<p>Sine of 156.4° ($180 - 23.6$) will be the same as the sine of 23.6°.</p>
<p>Step 6 Indicate other co-terminal points if necessary. Check this with the graph you drew previously.</p>	 <p>sine of 383.6° ($360^\circ + 23.6^\circ$) and 516.4° ($360^\circ + 156.4^\circ$) etc. will be the same as $\sin 23.6^\circ$.</p>
<p>Final Step Check your answer.</p>	<p> $\sin 23.6^\circ = 0.400349$ $\sin 156.4^\circ = 0.400349$ $\sin 383.6^\circ = 0.400349$ $\sin 516.4^\circ = 0.400349$ </p>

Example

Using your calculator, find the angles (to the nearest degree) in the domain between 0° and 360° that have a sine of 0.56.

Step 1

To find the angle in the first quadrant use your calculator.

$$\begin{aligned}\sin \theta &= 0.56 \\ \sin^{-1} 0.56 &= \theta \\ \theta &\approx 34^\circ\end{aligned}$$

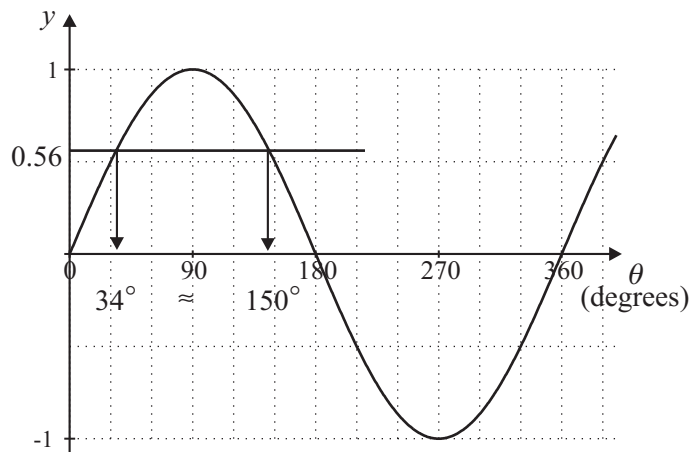
Step 2**Step 3**

Sin is positive in the first and second quadrants.

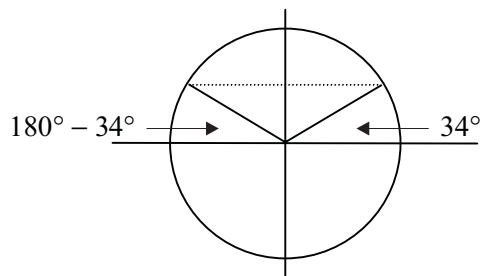
Step 4 and 5**Final Step**

Check by putting these angles in the calculator. $\sin 34^\circ = 0.559$; and $\sin 146^\circ = 0.559$.

Example

(As you become more practised with these examples, you may not need to do every step in detail.)

Using your calculator, find x (to the nearest degree) in the domain between 0° and -360° that satisfies the equation, $\sin x = 0.7$

Step 1

On your calculator find the angle that gives a sin of 0.7.

$$\sin^{-1} \theta = 0.7$$

$$\theta \approx 44^\circ$$

Notice that the calculator gives an acute angle but it's not in the stated domain.

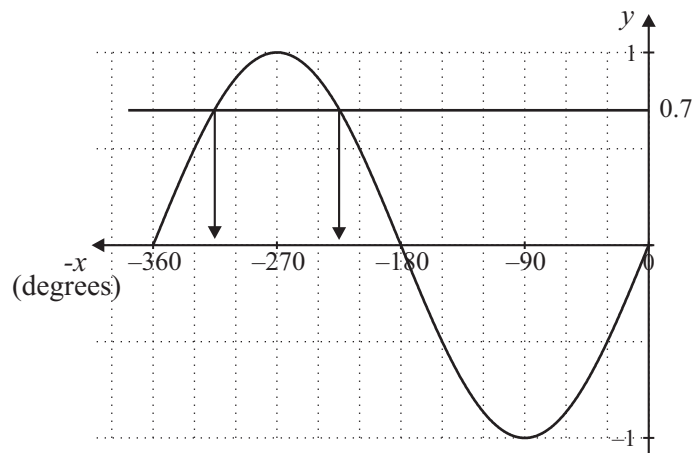
Step 2**Step 3**

Sin is positive in the first and second quadrants.

Step 4

The domain is between -360° and 0° , we must draw angles going in the negative direction and they must be in the 2nd and 3rd quadrants.

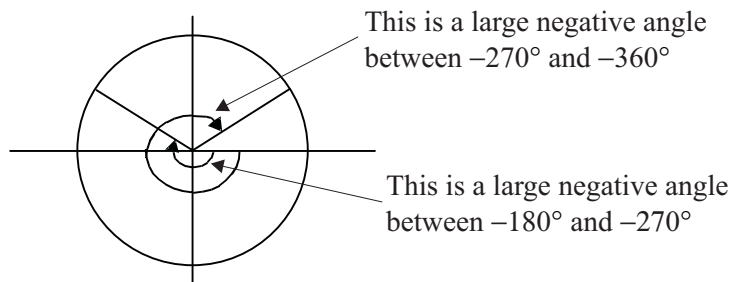

Step 5

The acute angle is 44° , so the angle in the 1st quadrant would be $-(360^\circ - 44^\circ) = -316^\circ$
 The angle in the 2nd quadrant would be $-(180^\circ + 44^\circ) = -224^\circ$

Step 6

Check by putting these angles in the calculator. $\sin(-224^\circ) = 0.6947$; and
 $\sin(-316^\circ) = 0.6947$.

Example

Find all angles between 0° and 360° (to the nearest tenth of a degree) that have a sin of -0.43 .

Step 1

$$\sin^{-1} \theta = -0.43$$

$$\theta \approx -25.5^\circ$$

Notice this gives an angle in the 4th quadrant.

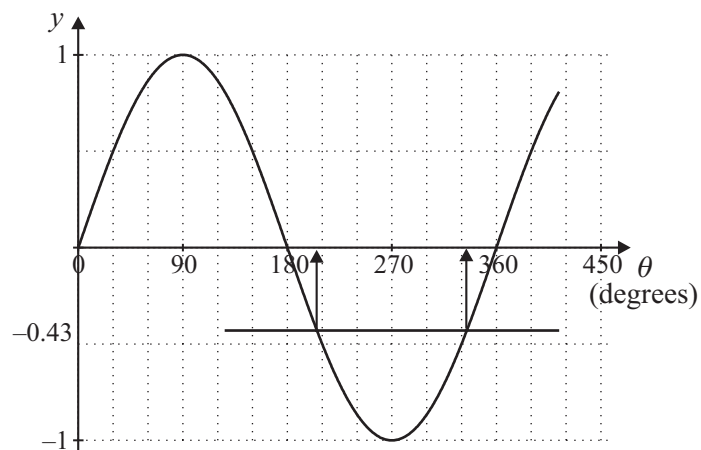
Step 2**Step 3**

Sin is negative in the 4th and 3rd quadrant.

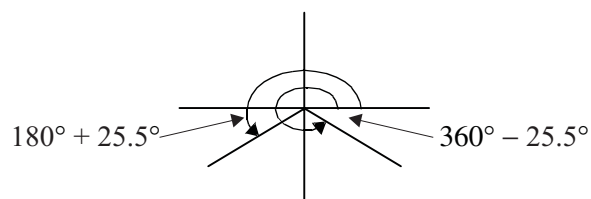
Step 4

Step 5

In the 4th quadrant:

$$-25.5^\circ \text{ is the same as } (360 - 25.5)^\circ = 334.5^\circ$$

In the 3rd quadrant:

$$(180 + 25.5)^\circ = 205.5^\circ$$

Step 6

Check $\sin 205.5^\circ \approx -0.43$
 $\sin 334.5^\circ \approx -0.43$

Activity 8.7

Find the angles (to the nearest degree) in the specified domain that have the following sines:

- (a) 0.4225 (from 0° to 360°)
- (b) 0.7124 (from 200° to 400°)
- (c) -0.5 (from 200° to 400°)
- (d) 0.1564 (from 0° to -270°)
- (e) 0.9511 (from 50° to 450°)
- (f) -0.8387 (from 0° to -360°)

8.1.4 Degrees, minutes and seconds

In activity 8.7, you were asked to find the angle whose sine is 0.7124 (i.e. $\sin^{-1} 0.7124$). You will find it is about 45.4305° (correct to 4 decimal places). But what does the decimal mean? It is 0.4305 of a degree. Just like hours are broken into smaller parts (minutes) and then smaller parts again (seconds) so are degrees. The word minute is from the Latin *pars minuta prima* – first small part, and second comes from *pars minuta secunda* – second small part. You can change from decimal fractions of a degree to minutes and seconds by multiplying by 60. So 0.4305 of a degree is $0.4305 \times 60 = 25.83$ minutes (use the symbol ' for minute). The 0.83 of a minute would then be $0.83 \times 60 = 49.8$ seconds (use the symbol '' for second).

Some calculators will do this for you (it may be the $^\circ ' ''$ key). So $45.43^\circ = 45^\circ 25' 50''$

Note:

$45^\circ 25' 50''$ means 45 degrees
 25 minutes (meaning 25/60 degree)
 50 seconds (meaning 50/60 of a minute or 50/3600 of a degree)

Example

Change $27^\circ 22' 55''$ to degrees.

$$\begin{aligned}27^\circ 22' 55'' &= 27 + \frac{22}{60} + \frac{55}{3600} \\ &\approx 27.3819^\circ\end{aligned}$$

Try this on your calculator.

Example

Change 75.87° to degrees, minutes and seconds.

$$\begin{aligned}75.87^\circ &= 75^\circ + \frac{87}{100} \times 60 \\ &= 75^\circ 52' 2'' \\ &= 75^\circ 52' + \frac{2}{10} \times 60 \\ &= 75^\circ 52' 12''\end{aligned}$$

Try this on your calculator. You may have to use the inv or shift key.

Activity 8.8

- Convert the following degrees in decimal form to degrees, minutes and seconds.
 - 36.8699°
 - 8.2150°
 - 128.0208°
- Convert the following to degrees in decimal form.
 - $22^\circ 14' 56''$
 - $4^\circ 29' 33''$
 - $285^\circ 05' 20''$

8.1.5 Amplitude

Go back to our seesaw once again. Here we saw the relationship between the height above the ground, length and the angle can be written as $h = l \sin \theta$.

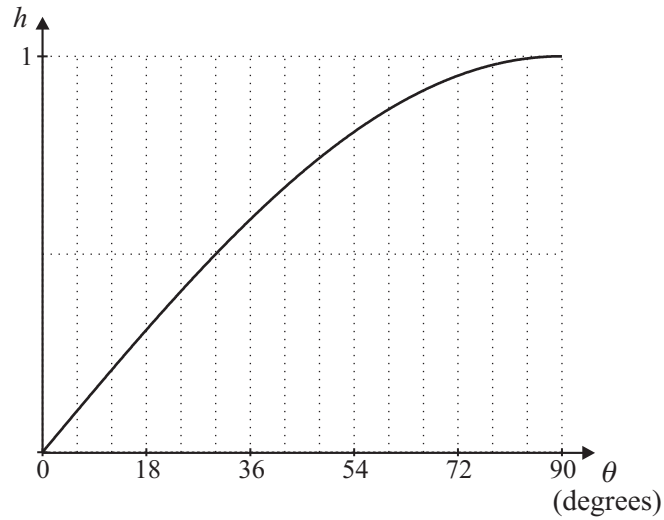

Looking at the graph (reproduced above) we can find the height of any seesaw if the length (l) of the seesaw was 1 metre. What if we changed the length of the seesaw to 2 metres? (Use your model.)

Write a sentence guessing what would happen.

If you said the heights would double you would be right.

Let's look at this graphically.

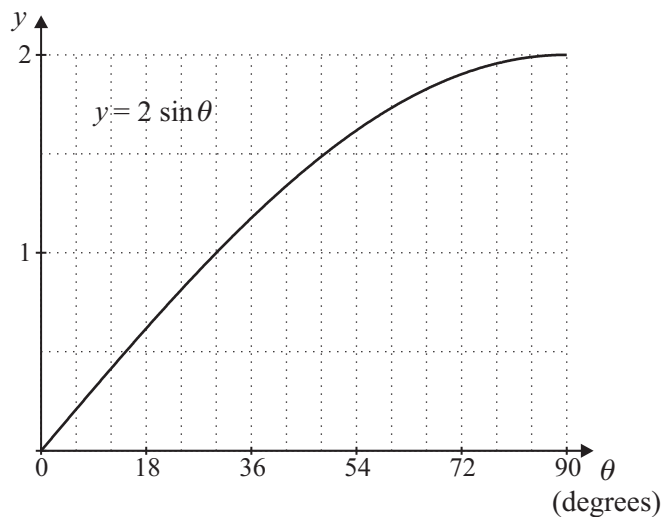

See the height of the ‘wave’ is higher. If we extend this idea to the function over a bigger domain you can see this very clearly:

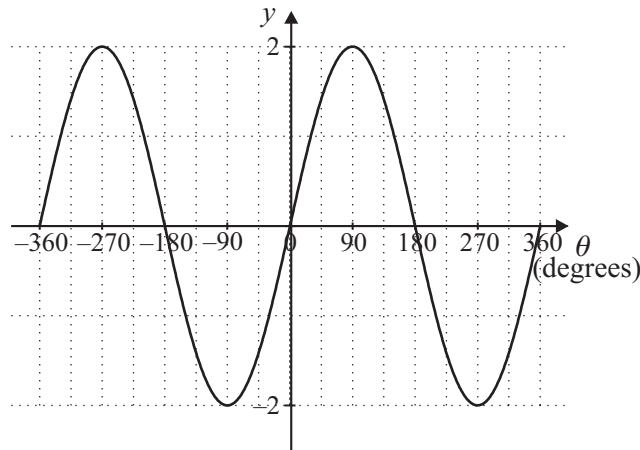

Activity 8.9

Draw the graphs of these functions on the same graph paper (or you may use a graphing package)

- (a) $y = 3 \sin \theta$
- (b) $y = 0.25 \sin \theta$

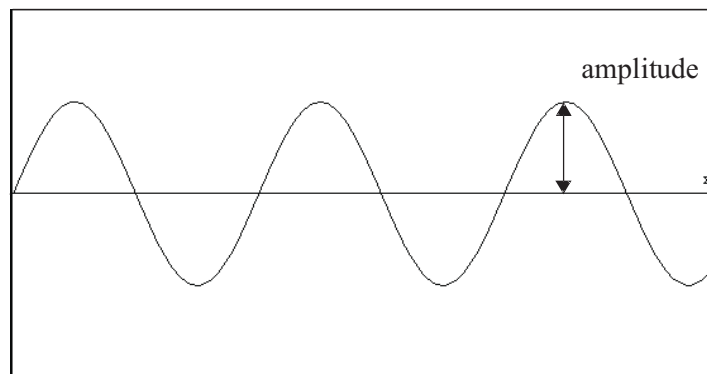

The height of the ‘wave’ is called the amplitude – or more exactly it is half of the distance between the maximum and minimum values of the function.

The amplitude has many applications. For example the loudness of a sound depends upon the amplitude of its wave. The figure below shows the sound produced by a trumpet.

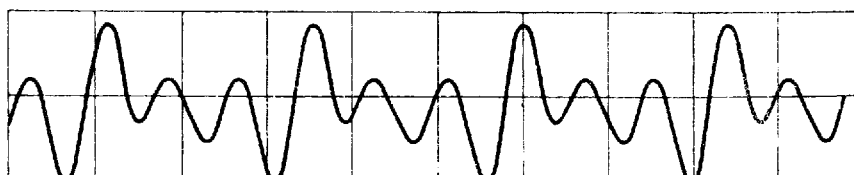

Activity 8.10

Find the amplitude of the following sine functions.

(a)

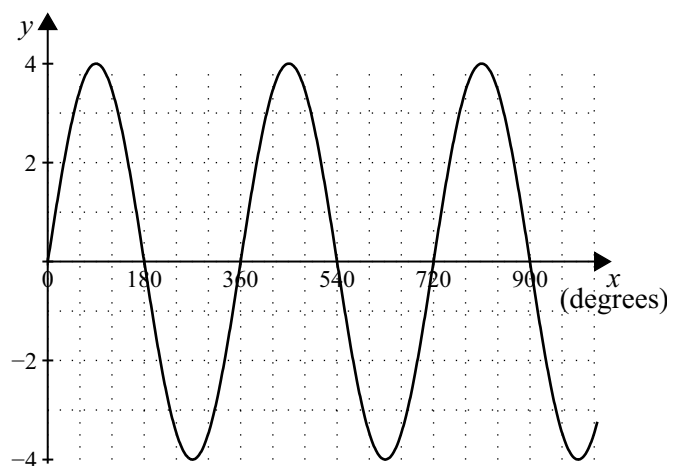

(b)

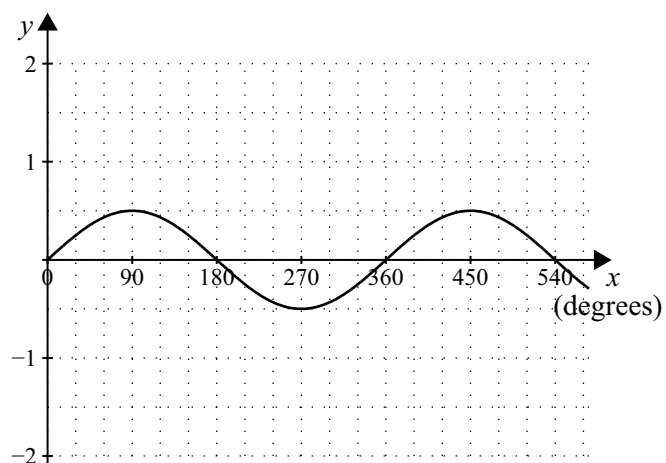

(c)

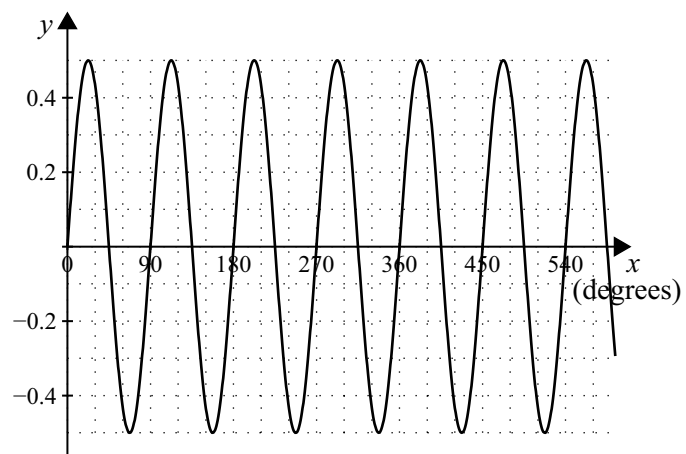

8.1.6 Period

One of the beauties of the sine curve is its repetitiveness. Look at the curve you drew in activity 8.5, no.2 and the circle.

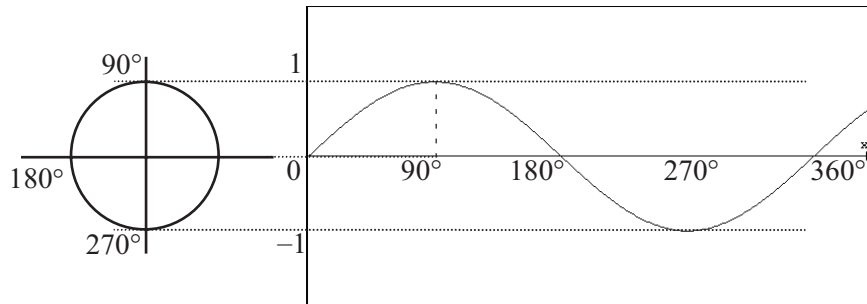

When the angle goes around from 0° through to 90° then to 270° then to 360° , at the same time the sine curve has gone from 0 up to one, down to minus one then up to zero. If we keep going, the angle goes around the circle again, at the same time the sine curve repeats itself. When this happens, we say the function is periodic.

It is this periodic feature of the sine curve that is important. For example, in electrical currents, one rotation corresponds to one cycle. (Have you heard of 50 Hertz in electrical terms – this means the number of cycles per second.)

The period of a function is the distance along the x axis of one wave length (or the smallest complete curve that is repeated).

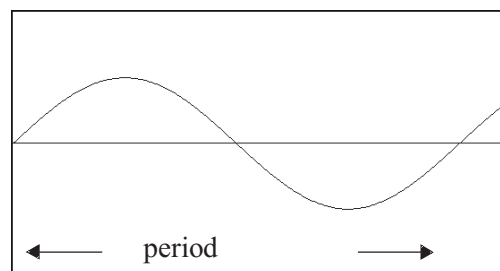

Example

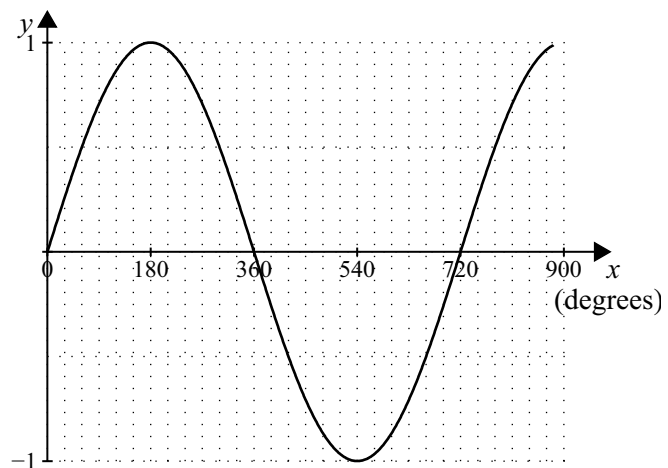

In the periodic function above, determine the period.

The function repeats every 720° so the period is 720° .

Activity 8.11

Look at the periodic functions below and determine the period.

(a)

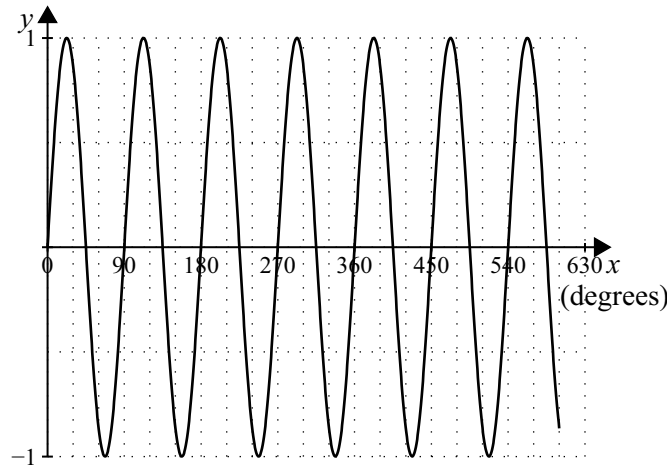

(b)

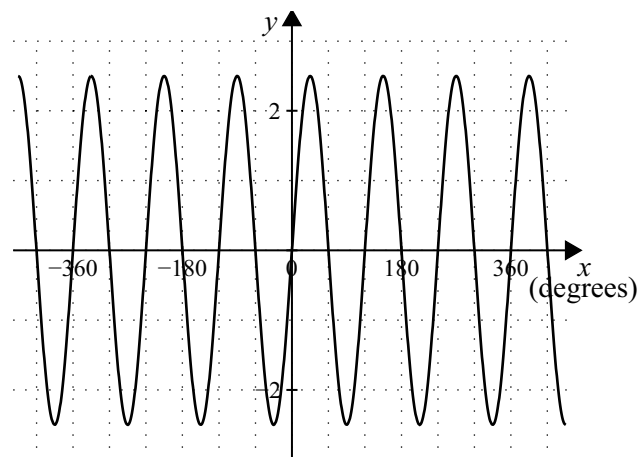

(c)

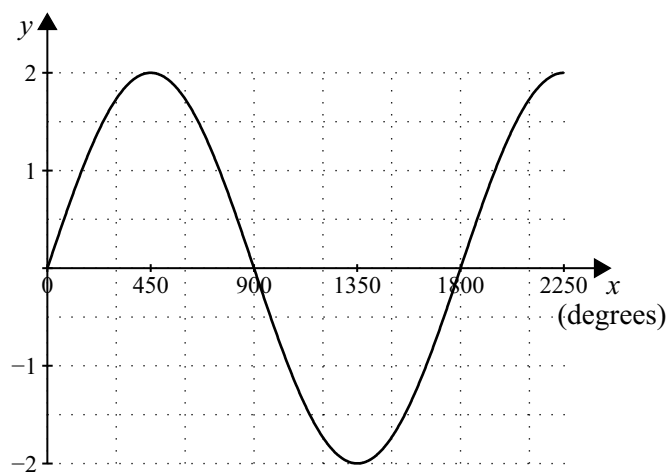

Time to assess...

You are about one third through this module. If you have understood all of this section so far the rest will be relatively easy. Maybe now is a time to go over the work you have done. Have you made some notes and selected key examples? Is there anything you are unsure about? Maybe now is the time to contact your tutor, or join in the discussion group.

8.2 The cosine story

The cosine story is similar to the sine story. The concept of the cosine has a much later history than that of sine. It arose from the need to compute the sine of **complementary** angles (complementary means angles that add to give 90°), hence the name **co**-sine. As you read through this section think about the similarity of the cosine story with the sine story.

8.2.1 The cosine ratio

Let's go back to the lighthouse problem from activity 8.1.

Jack West is in a boat. He sees another boat in front of him and talks to the owners over the radio. The other boat operator says: 'I am exactly 20 km east of the lighthouse'. Jack then moves his boat so he is directly south of the other boat. His mate Jill, measures the angle between the other boat and the lighthouse and finds it to be 25° .

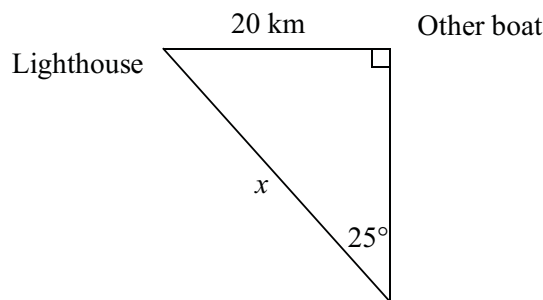

Suppose in this problem, the Wests wanted to find out how far they were from the other boat. How could they do it?

Well they could use Pythagoras' theorem.

The answers are in the table below. What do you notice about these numbers? You may wish to compare these numbers with the ones you found for the sine ratio.

θ	0°	12°	24°	30°	35°	48°	60°	70°	90°
$\cos \theta^\circ$	1	0.9781	0.9135	0.8660	0.8192	0.6691	0.5	0.3420	0
$\sin \theta^\circ$	0	0.2079	0.4067	0.5	0.5736	0.7431	0.8660	0.9397	1

You should have noticed some of the following things about the cosine ratios:

- They are between and including 0 and 1.
- They are not proportional e.g. the cosine of 12° is not twice the cosine of 24° .
- While the sine of 0° is zero the cosine of zero is 1; similarly for 90° .
- They get smaller as the angle gets larger. (Compare to the sine ratios which got bigger as the angle got larger.)
- The difference between the cosine of 12° and 24° is quite small (about 0.06), but the difference between 70° and 82° is quite large ($0.3420 - 0.1392 = 0.2028$).
- There appears to be some connection – the sin of 30° is the same as the cos of 60° . 30° and 60° are complementary angles. Similarly 20° and 70° ; 42° and 48° etc. – are all complementary angles – check this yourself on the calculator in the activity below.

Example

What angle is complimentary to 50° ? If $\cos 50^\circ = 0.6428$, then what can we say about the angle complimentary to 50° ?

40° is complimentary to 50° .

If $\cos 50^\circ = 0.6428$ then $\sin 40^\circ = 0.6428$.

Activity 8.12

- Without using a calculator, determine which of the following are incorrect.
 - $\sin 60^\circ = \cos 30^\circ$
 - $\cos 20^\circ = \sin 80^\circ$
 - $\cos 15^\circ = \sin 75^\circ$
- Solve for θ without using a calculator.
 - $\cos 25^\circ = 0.9063$, $\sin \theta = 0.9063$
 - $\cos 73^\circ = 0.2924$, $\sin \theta = 0.2924$

Let's have a look at some practical examples, just like we did with the sine ratio.

Example

A 6 m ladder leans against a wall so that it makes an angle of 20° with the ground. How far is the bottom of the ladder away from the wall?

Firstly, draw a diagram.

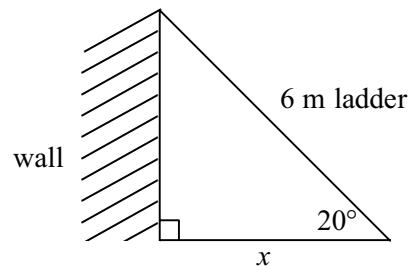

We know the hypotenuse (the length of the ladder), the angle (20°) and wish to find the length of the side adjacent to the angle (the length along the ground to the foot of the ladder – x).

$$\cos \theta = \frac{\text{adjacent side}}{\text{hypotenuse}}$$

$$\cos 20^\circ = \frac{x}{6}$$

$$6 \times \cos 20^\circ = x$$

$$\begin{aligned} \text{So the adjacent length} &= 6 \times \cos 20^\circ \\ &= 6 \times 0.93969262 \quad \text{Never round off until the final step} \\ &\approx 5.64 \end{aligned}$$

Hence the foot of the ladder is about 5.64 m from the wall.

Activity 8.13

1. A flying fox sloping at an angle of 20° to the horizontal is to be attached between two trees 50 m apart. What length of cable is required?
2. A gable roof is to span an 8 m width. If the roof has a 22.5° pitch, what is the length of the rafter (a sloping beam to hold the roof) assuming a 600 mm overhang?
3. A bush walker made a simple lean-to using branches having an average length of 1.8 m. If the branches were resting against a vertical rock face at an angle of 50° with the ground, what floor width did the bush walker have to rest on?

8.2.2 The cosine function

Just like the sine function, the cosine function can be graphed.

Take the values of θ and $\cos \theta$ between 0° and 90° in the section above and graph the information. Use the same scale that you used for the sine function (You could even use the same graph paper).

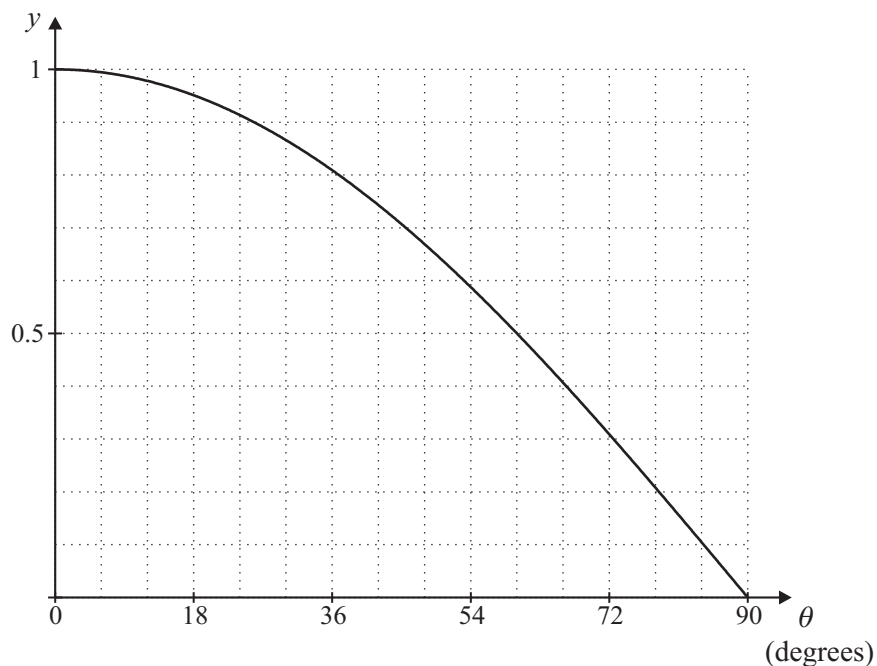

See how this is similar to the sine curve. To see the similarity more clearly, we will look at the curve for larger values of θ . To do this we will again treat an angle as the amount of turning, and the cosine related to a point on the circle.

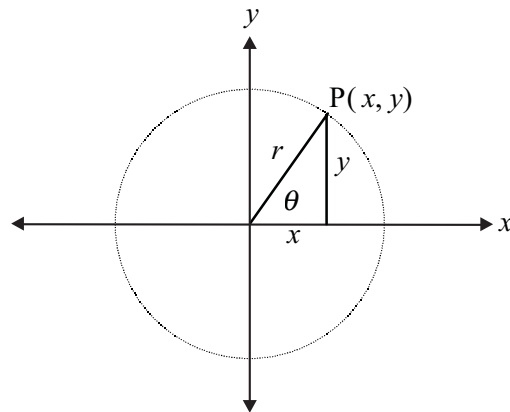

In the diagram above $\cos \theta = \frac{x}{r}$

Example

If the radius is 1 unit, what is the x -coordinate of P in the diagram below.

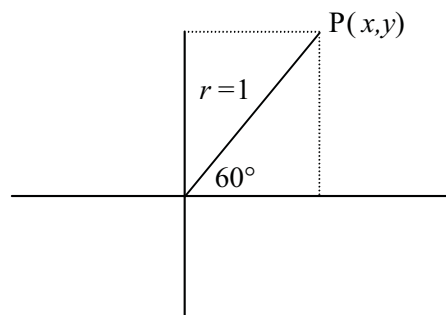

$$\cos 60^\circ = \frac{x}{r}$$

If $r = 1$ and $\cos 60^\circ = 0.5$

then $x = 0.5$

Activity 8.14

1. Find the value of x in the following diagrams.

(a)

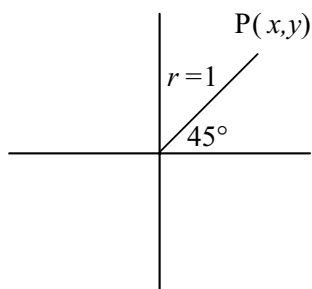

(b)

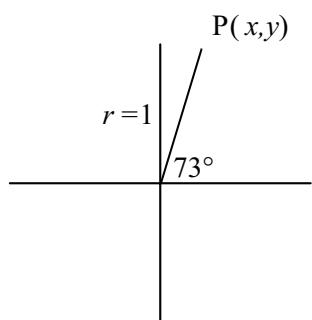

(c)

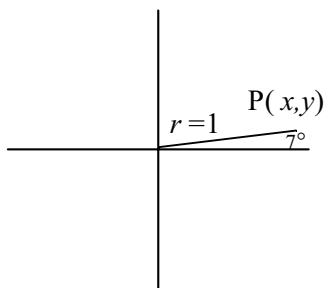

(d)

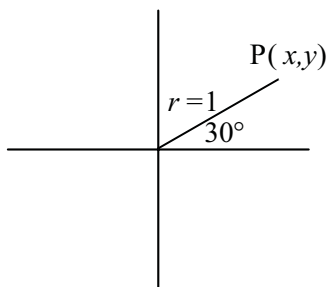

Now look at angles greater than 90° . In the diagrams below we again superimpose the coordinate system on the circles.

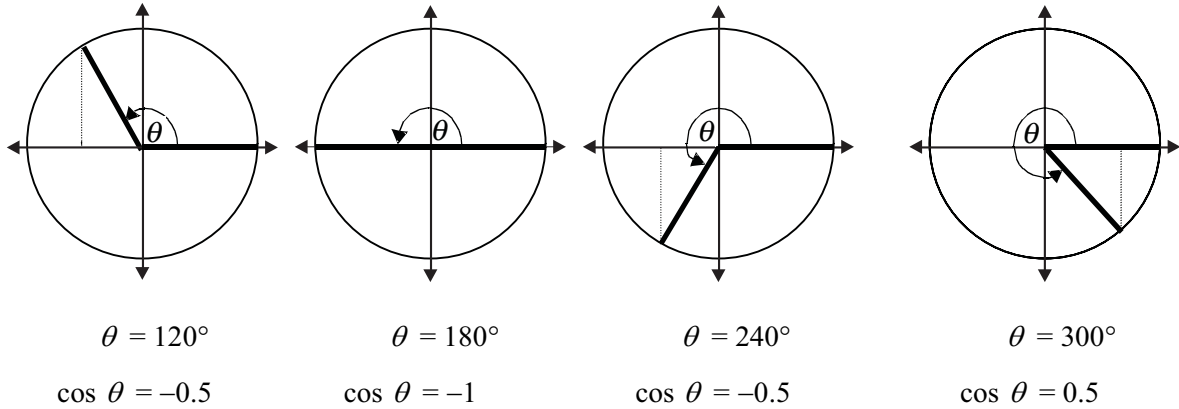

Note the following:

- 120° is in the 2nd quadrant. The x -coordinate of P will be negative.
- 240° is in the 3rd quadrant, but the x -coordinate of P will also be negative. So you can see that the cosine of angles between 90° and 270° are negative.
- 300° is in the 4th quadrant. The x -coordinate is positive so the cosines of angles between 270° and 360° are positive.

Activity 8.15

1. The following table will be a useful summary, similar to the sine one you did in activity 8.3. We will revisit this once we have looked at the third trigonometric ratio.

(a)

θ	$\cos \theta$
0°	
90°	
180°	
270°	
360°	

(b) Cosine is positive in the _____ quadrants.

Cosine is negative in the _____ quadrants.

2. Determine the quadrant into which the following angles will fall and whether the cosine of the angles will be positive or negative. Then, on your calculator find the cosine of these angles:

α	Quadrant	Sign (\pm)	$\cos \alpha$
250°	3rd	-	-0.3420
125°			
160°			
189°			
235°			
280°			
320°			
350°			
390°			
520°			
600°			
650°			
-250°			
-200°			
-100°			

Example

Find an angle with the same cosine as 25°.

Consider the angle 25°.

- Place the angle 25° in a unit circle and mark the point P on the circle.
- Find the x -coordinate of P.
- Find another point Q on the circle, with the same x -coordinate.
- What is the angle that places Q in this position?

To place the angle 25° in a unit circle draw a diagram as below.

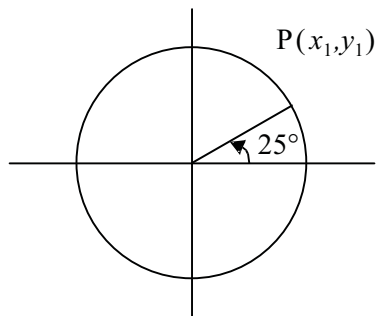

The x -coordinate of P is:
 $x = \cos(25^\circ) \approx 0.9063$

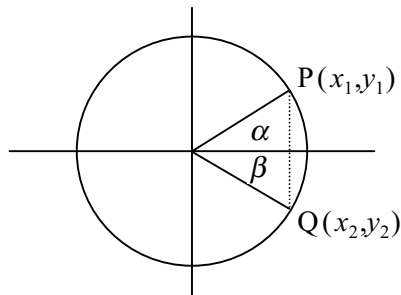

The point Q will have the same x -coordinate as P. Notice the equivalent angles that are formed.

Since the original angle was 25° , the angle β will be $360^\circ - 25^\circ = 335^\circ$. Check this on the calculator. $\cos 335^\circ \approx 0.9063$.

Activity 8.16

- Find angles with the same cosine as (a) 290° and (b) 60° by doing the following steps.

Consider the angles (a) 290° and (b) 60° .

 - Place the angle in a unit circle and mark in the point P on the circle.
 - Find the x -coordinate of P.
 - Find another point Q, on the circle with the same x -coordinate
 - What is the angle that places Q in this position?
- On your own graph paper, plot the function $y = \cos \theta$ for the domain $-360^\circ < \theta < 360^\circ$.
 - Write a sentence comparing the sine and cosine curves.

8.2.3 The inverse of the cosine function

Just like the sine function, there is an inverse to the cosine function. Recall:

$\sin^{-1} 0.56 = \theta$ means what angle gives a sine of 0.56. It can be written as:
 $\sin \theta = 0.56$

Step 1

To find the answer we pressed the **sin**⁻¹ key on the calculator to give
 $\theta \approx 34^\circ$.

This was just one answer.

Step 2–5

We then estimated other angles with the same sine by sketching the sine curve, placing the angles in the appropriate quadrants then finding the exact angles.

Final Step

Check your answer.

Now we can do the same with the inverse of the cosine function.

Example

Find angles between 0° and 720° that have a cosine of 0.4.

Step 1

$\cos \theta = 0.4$ means what angle gives a cosine of 0.4. It can be written as:
 $\cos^{-1} 0.4 = \theta$.

To find the answer we pressed the **cos**⁻¹ key on the calculator to give
 $\theta \approx 66.421822^\circ$

(There should be a **cos**⁻¹ button usually above the **cos** button.)

Step 2

Find other angles with the same cosine. It's a good idea to draw a quick sketch of the cosine curve to estimate the angles with the same cosine.

If we look at the graph of $y = \cos \theta$ that you drew in 8.16, we can find approximate angles that have the same cosine.

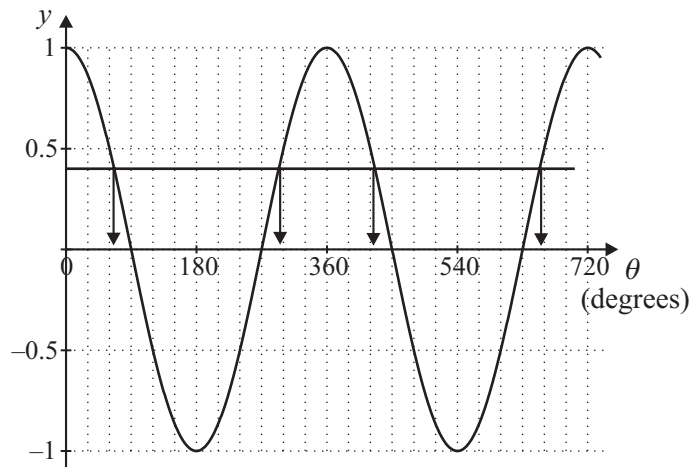
**Step 3**

To find these other angles more accurately, we must again look at the quadrants. The cosine is positive in the 1st and 4th quadrants.

Step 4

In the 4th quadrant the angle has the same x -coordinate as the angle in the first quadrant.

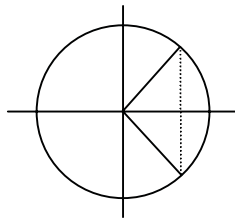
**Step 5**

To find the exact angle in the 4th quadrant, we must subtract 66.4° from 360° . Cosine of $(360^\circ - 66.4^\circ)$ 293.6° will be the same as the cosine of 66.4° .

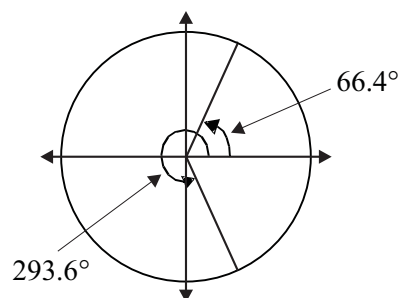

Step 6

Other angles with the same cosine will be co-terminal angles, therefore $360^\circ + 66.4^\circ$ and $360^\circ + 293.6^\circ$ etc. will have a cos of 0.4.

Therefore $\cos^{-1} 0.4 = 66.4^\circ; 293.6^\circ; 426.4^\circ; 653.6^\circ$.

Final step

Check your answer

$$\cos 66.4^\circ = 0.400349$$

$$\cos 293.6^\circ = 0.400349$$

$$\cos 426.4^\circ = 0.400349$$

$$\cos 653.6^\circ = 0.400349$$

So the answer is correct (to 3 decimal places).

Example

Using your graph of the cosine function, find approximate angles between 0° and 360° which have a cosine of -0.3450 . Now using your calculator, find these angles correct to 4 decimal places.

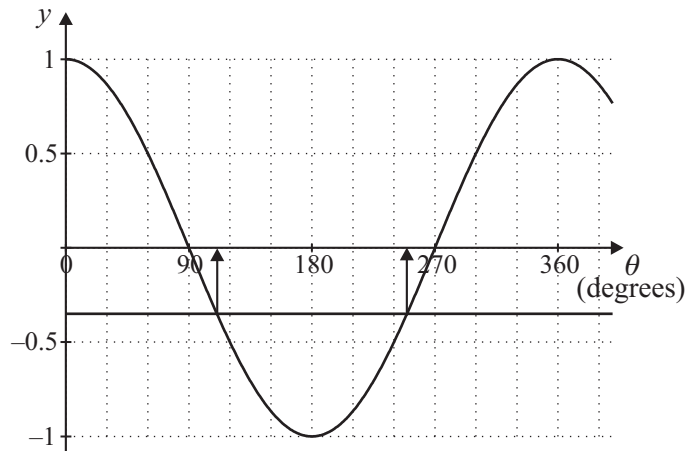

The angles will be about 110° and 250°

$$\cos^{-1} -0.3450 = \theta$$

$$\theta = 110.1818^\circ$$

Cos is negative in the 2nd and 3rd quadrants.

In the diagram the point P has the same x -coordinate as the point Q.

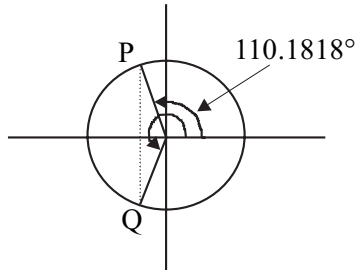

To find the angle in the 3rd quadrant we need to find the angle marked α which is the same size as the angle marked β .

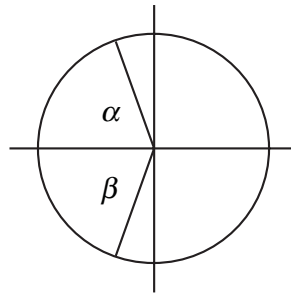

$$\alpha \approx 180^\circ - 110.1818^\circ \approx 69.8182^\circ$$

$$\beta \approx 69.8182^\circ$$

So the angle that gives a cosine of -0.345 is $180^\circ + 69.8182^\circ = 249.8182^\circ$

Check this on the calculator: $\cos 249.8182^\circ \approx -0.345$

Activity 8.17

- Using your graph of the cosine function, find angles that have the following cosines:
 - 0.44
 - 0.03
 - 0.87
 - 0.43
- Using your calculator and the unit circle find the angles which have the cosines from the previous exercise (correct to the nearest degree).
- Find θ ($0^\circ < \theta < 360^\circ$), if:
 - $\cos^{-1} -0.24 = \theta$.
 - $\cos^{-1} 0.83 = \theta$.
- Find angles in the specified domain that have the following cosines.
 - 0.5 (from 0° to -360°)
 - 0.9397 (from 200° to 400°)
 - 0.0523 (from 180° to 360°)
 - 0.7071 (from 90° to 450°)

8.2.4 Amplitude

Look at the graph of $y = 0.5\cos \theta$, what do you think the amplitude would be?

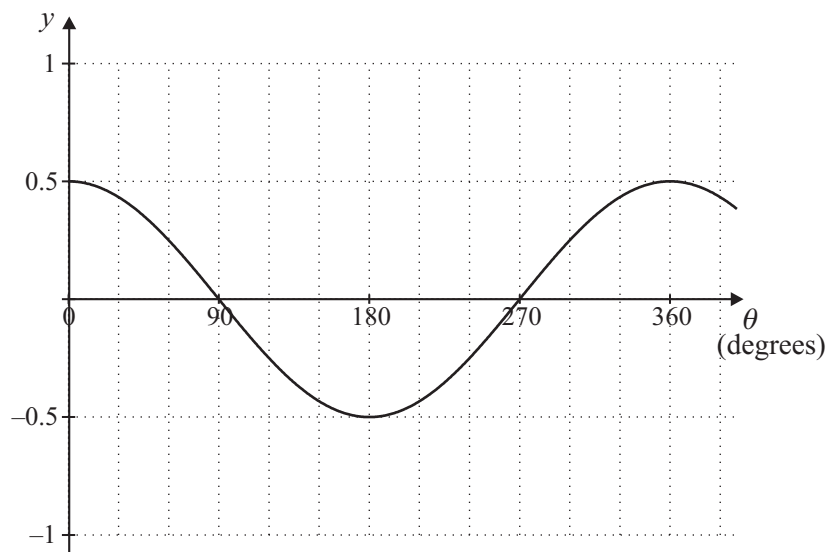

The amplitude will be 0.5 since this is half the distance between the maximum and minimum values of the function.

Activity 8.18

Draw the graph of the functions on the same graph paper. What is the amplitude of these two functions. Can you guess the amplitude from the equation of the curve?

- (a) $y = 3 \cos \theta$
- (b) $y = 0.25 \cos \theta$

8.2.5 Period

Just like the sine curve, the cosine curve is periodic. That is, it has a repeating curve. Can you see the period of $y = \sin \alpha$ is the same as $y = \cos \alpha$?

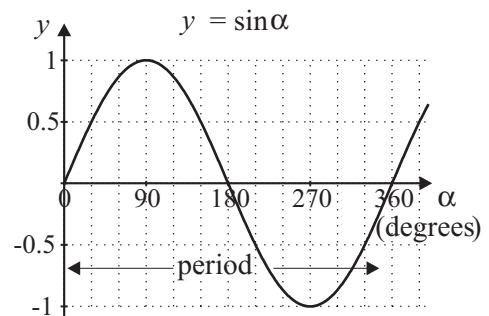
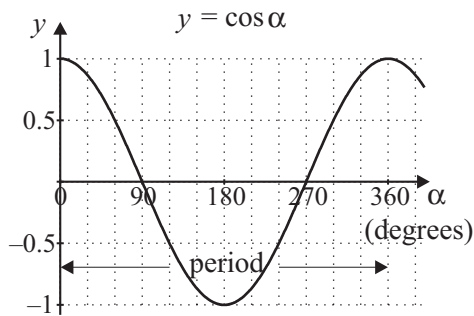

Activity 8.19

Look at the periodic functions below and determine the period.

- (a)

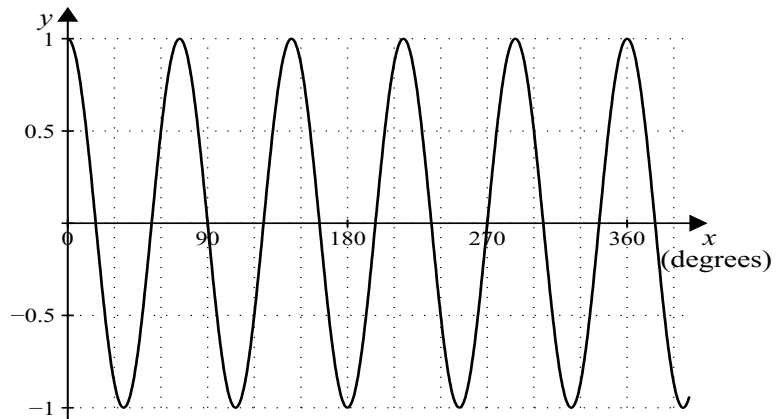

(b)

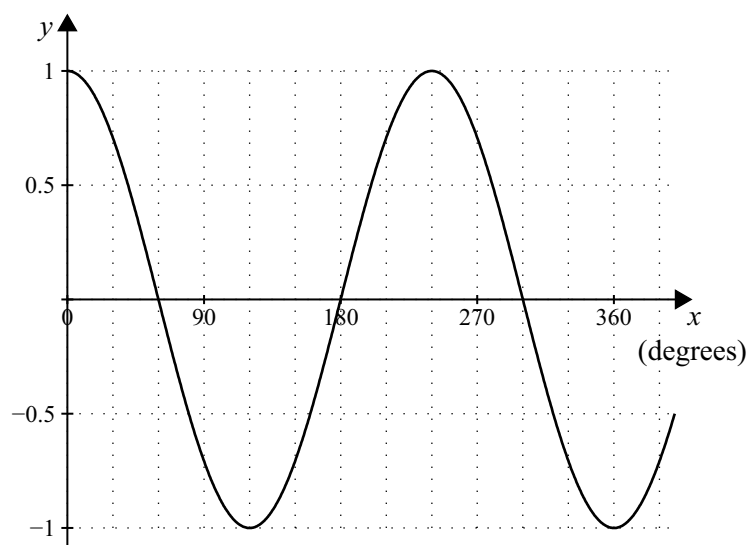

(c)

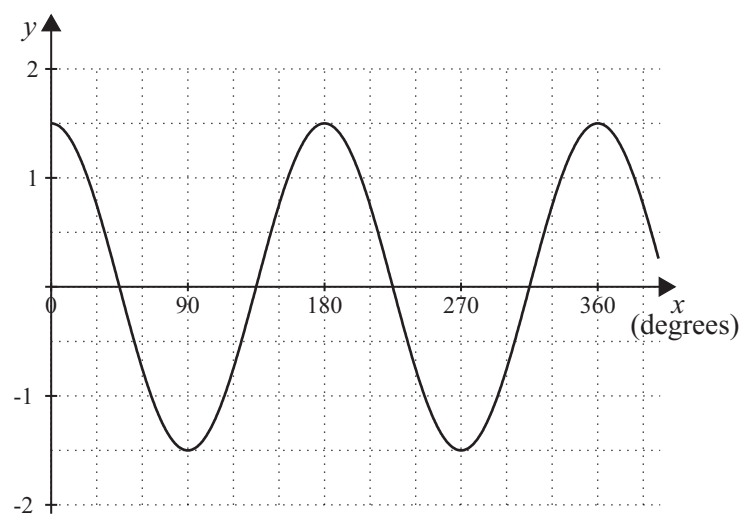

8.3 The tangent story

The concept of tangent was used in ancient times when people measured the height of objects from the shadows that they cast. Plutarch, an ancient Greek biographer and historian, wrote:

Whereas he (the king of Egypt) honours you, he particularly admires you for the invention whereby, with little effort and by the aid of no mathematical instrument, you found so accurately the height of the pyramids. For having fixed your staff erect at a point of the shadow cast by the pyramid, two triangles were formed by the tangent rays of the sun and from this you showed that the ratio of one shadow to the other was equal to the ratio of the (height of the) pyramid to the staff.

(Maor 1998, p. 21)

Further development occurred in the late 9th century when a Mesopotamian astronomer constructed a ‘table of shadows’ for each degree from 0° to 90° . However it wasn’t until 1583 that the word ‘tangent’ started to be used. Let’s revisit the tangent ratio and look at some practical examples.

8.3.1 The tangent ratio

Recall the West’s fishing boat example. The West’s knew the angle and the distance from the other boat to the lighthouse. We could have used this information to find the distance from their boat to the other boat, by looking at the tangent ratio.

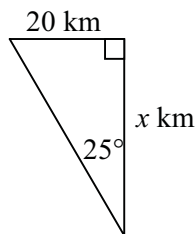

The two pieces of information we know are the side **opposite** the angle 25° and the angle of 25° . We need the **adjacent** side. The ratio of the opposite side to the adjacent side, is called the tangent ratio.

In a right angled triangle, tangent of an angle = $\frac{\text{opposite side}}{\text{adjacent side}}$

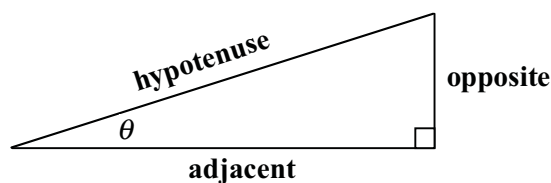

In the West's boat case:

$$\begin{aligned}\tan 25^\circ &= \frac{20}{x} \\ \tan 25^\circ x &= 20 \\ x &= \frac{20}{\tan 25^\circ} \\ x &\approx 42.890\end{aligned}$$

So the West's boat is about 43 km from the other boat.

Activity 8.20

1. Draw a diagram to represent the pyramid problem in section 8.3, and show how you can use the tangent ratio to solve the problem.
2. Find the tangent of the following angles on your calculator:

φ	0°	12°	24°	30°	35°	48°	60°	70°	90°
$\tan \varphi$									

Look at the answers you found in the activity above. What do you notice about these numbers? You may wish to compare them to the sin and cos ratios.

φ	0°	12°	24°	30°	35°	48°	60°	70°	90°
$\cos \varphi$	1.0	0.978	0.914	0.866	0.819	0.669	0.5	0.342	0.0
$\sin \varphi$	0	0.2079	0.4067	0.5	0.5736	0.7431	0.8660	0.9397	1
$\tan \varphi$	0	0.213	0.445	0.577	0.700	1.111	1.732	2.747	E?

You should have noted some of the following things about the tangent ratios.

- They get larger as the angle gets larger.
- The numbers are **not** restricted to between 0 and 1.
- They are not proportional e.g. the tan of 30° is not half the tan of 60° .
- The calculator does not like $\tan 90^\circ$ (E means error on the calculator).
- The ratio of the sine to the cosine is equal to the tangent. (We will look at this more closely in the next section.)

Let's have a closer look at the tangent of 90° .

Why does the calculator give an error message? To answer this question, look at the curve as we did with the sine ratio.

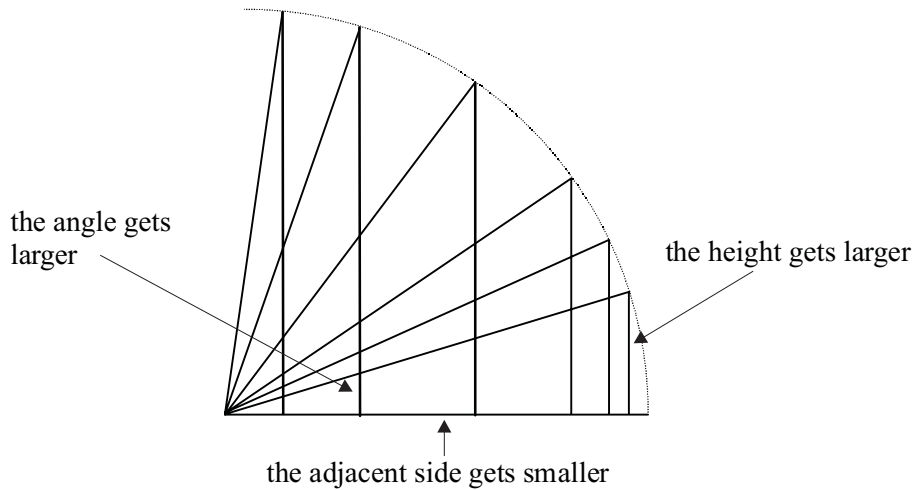

As the angle increases the side opposite increases, but at the same time the side adjacent is getting smaller. At what angle is the tangent going to be 1?

If you said 45° you would be right. Here the opposite and adjacent sides are the same. But as the angle gets closer to 90° the tan ratio becomes very large. Let's look at this more closely.

Find the tan ratio of following angles:

α	$\tan \alpha$
80°	
85°	
89°	
89.9°	
89.999°	

You should have the following answers:

α	$\tan \alpha$
80°	5.67
85°	11.43
89°	57.29
89.9°	572.96
89.999°	57295.78

Theoretically we can get as large as we like, but you can see as the angle gets really close to 90° the number gets very large indeed. In fact when it's 90° the triangle disappears, the tangent of the angle 90° becomes infinitely large. In terms of the triangle the adjacent side becomes zero. We cannot divide by zero, so we say the tan of 90° is undefined.

Before we move on to the tangent function, let's have a look at some practical applications of the tangent ratio.

Example

A person lying on the ground 10 metres from a tree, calculates that the angle of elevation of the tree is 35° . How tall is the tree?

First draw a diagram and label the knowns and unknowns.

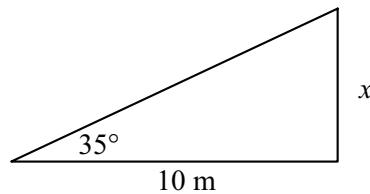

$$\tan \theta = \frac{\text{opposite}}{\text{adjacent}}$$

$$\tan 35^\circ = \frac{x}{10}$$

$$10 \times \tan 35^\circ = x$$

$$x = 10 \times \tan 35^\circ$$

$$= 10 \times 0.700207538$$

$$\approx 7$$

The tree is approximately 7 metres tall.

What if this question had given you the height of the tree as 7 metres and asked you to find the distance the person was away from the tree.

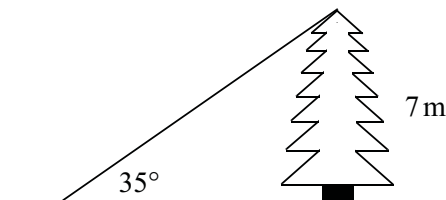

Again we would use the tangent ratio

$$\begin{aligned}\tan \theta &= \frac{\text{opposite}}{\text{adjacent}} \\ \tan 35^\circ &= \frac{7}{x} \\ x &= \frac{7}{\tan 35^\circ} \\ &= \frac{7}{0.700207538} \\ &\approx 9.997\end{aligned}$$

The person would be lying approximately 10 metres from the tree.

Activity 8.21

1. At a horizontal distance of 100 m from the foot of a television tower, the angle of elevation to the top is found to be 40° . How high is the tower?
2. Shadows tell us that the sun's rays land on earth at an angle. This angle varies throughout the day. Find the length of the shadow of a skyscraper 150 m high, when the angle of elevation of the sun is 28° .
3. A person standing on the deck of a boat which is 4 metres higher than a pier throws a rope to the pier. The angle of depression from the person to the pier is 22° . How far is the boat from the pier?
4. From two windows, one several stories directly above the other in a tall building, two workers are watching the window cleaners on the building opposite. The person in the top window notes that the angle of depression of the window cleaners is 21° , while the person at the lower window notes that the angle of elevation of the window cleaners is 28° . If the buildings are 42 metres apart, find the distance between the two windows.

8.3.2 The tangent function

Graph the information below on your own graph paper. Use a scale similar to the one you used for the sine and cosine graphs (1 cm represents 20°) for the horizontal axis, but for the vertical axis use one centimetre represents one. (You might like to add some values of φ between 70° and 90° .)

φ	0°	12°	24°	30°	35°	48°	60°	70°	80°	90°
$\tan \varphi$	0	0.213	0.445	0.577	0.700	1.111	1.732	2.747	5.671	E?

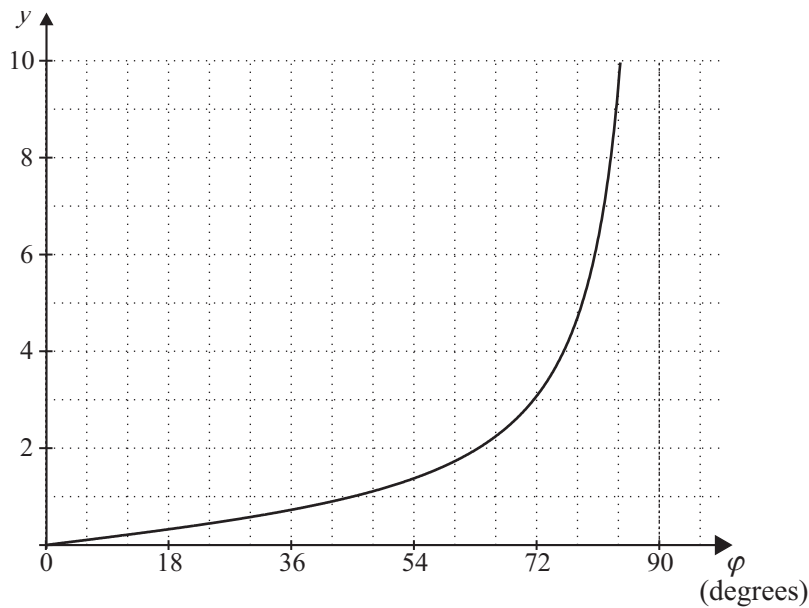

The tangent curve looks very different from the sine and cosine curves. The shape is not a wave. Notice as φ gets very close to 90° the curve gets steeper and steeper. If you draw a vertical line at $\varphi = 90^\circ$, then the curve would appear to be getting closer and closer to this line, but never touching. This line is called a vertical **asymptote**.

What happens as φ gets larger than 90° ?

To answer this we must firstly look at the tangent ratio in the circle just as we did with sine and cosine. In this case:

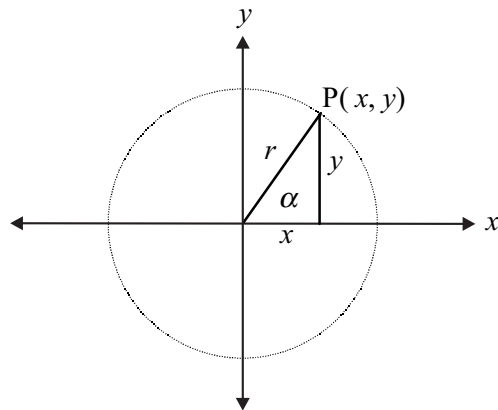

$$\tan \alpha = \frac{y}{x}$$

Example

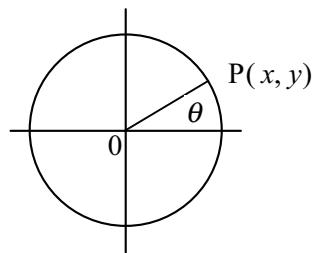

If $\theta = 22^\circ$, what is the value of $\frac{y}{x}$?

$$\tan \theta = \frac{y}{x}$$

$$\tan 22^\circ = \frac{y}{x}$$

$$0.4040 \approx \frac{y}{x} \quad (\text{Note: This is also the gradient of the line } OP.)$$

You should have already come across this concept in graphing of lines when you found the gradient of a straight line = $\frac{\text{rise}}{\text{run}}$.

Activity 8.22

Find the value of $\frac{y}{x}$ in the following diagrams.

(a)

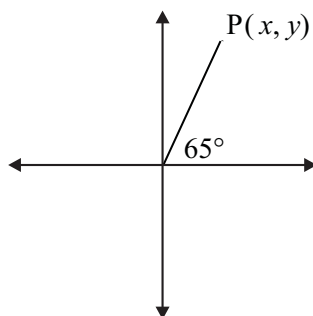

(b)

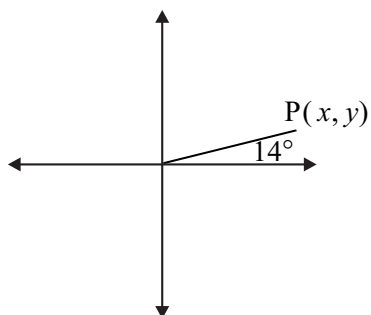

(c)

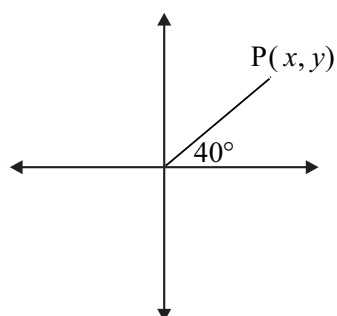

Now look at angles greater than 90°.

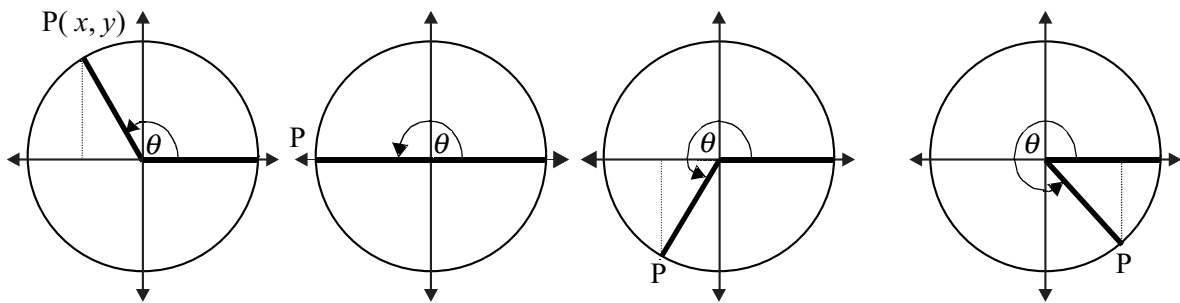

$\theta = 120^\circ$	$\theta = 180^\circ$	$\theta = 240^\circ$	$\theta = 300^\circ$
$\tan \theta \approx -1.7321$	$\tan \theta \approx 0$	$\tan \theta \approx 1.7321$	$\tan \theta \approx -1.7321$

In the case of the tangent, the coordinates themselves are not the trigonometric variables, but the ratio of the y -coordinate to the x -coordinate.

Note the following:

- You can see that the tangent of angles between 90° and 180° are negative since we are dividing a positive y by a negative x . (when $\theta = 120^\circ$, $x = -0.5$ and $y \approx 0.8660$).
- The tan of the angles between 270° and 360° are negative as well since we are dividing a negative y by a positive x (when $\theta = 300^\circ$, $x = 0.5$ and $y \approx -0.8660$).
- The tan of angles between 180° and 270° are positive. Can you see why this would be the case? In this case we are measuring the opposite side and adjacent side. When the angle is in the third quadrant both the adjacent and opposite sides are negative, so the result is positive (when $\theta = 240^\circ$, $x = -0.5$ and $y \approx -0.8660$).

Activity 8.23

1. The following table will be a useful summary. You should add these to your notes. Add the information you collected in activities 8.3 and 8.15.

(a)

θ	$\tan \theta$	$\sin \theta$	$\cos \theta$
0°			
90°			
180°			
270°			
360°			

(b) In the quadrants below state which ratios are positive:

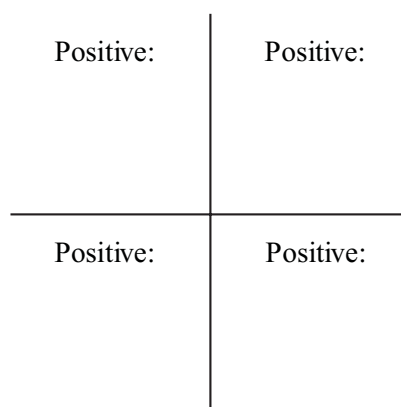

See special NOTE in solutions.

2. Determine the quadrant the following angles will fall; whether the tangent of the angles will be positive or negative. Then, on your calculator find the tangent of these angles:

α	Quadrant	Sign (\pm)	$\tan \alpha$
E.g. 250°	3rd	+	2.7475
125°			
160°			
189°			
235°			
280°			
320°			
350°			
390°			
520°			
600°			
650°			
-250°			
-200°			
-100°			

Something to talk about ...

It is useful to remember the information in these last two exercises. Ask your friends if there was any way they learnt how to remember this. Share your ideas with the discussion group.

Example

Find an angle that has the same tangent as 250° .

Consider the angle 250° .

- Place the angle 250° in a unit circle and mark the point P on the circle.
- Find the size of the **acute** angle (angle less than 90°) formed with the x -axis.
- Find another quadrant that has the tangent with the same sign.
- Find a point Q, on the circle in this quadrant that makes an angle with the same tangent.
- Find the coordinates of the point Q.

To place the angle 250° in the circle draw a diagram as below.

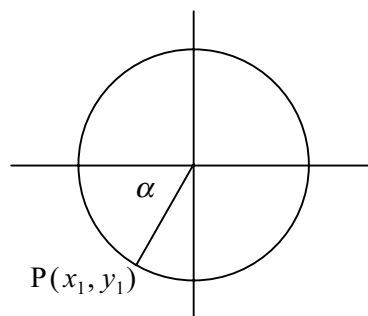

To find α , notice that 250° is made up of the straight angle 180° and an extra 70° .

$$\begin{aligned} 250^\circ &= 180^\circ + 70^\circ \\ \alpha &= 70^\circ \end{aligned}$$

$\tan 250^\circ$ is positive, so the other angle will be in quadrant 1, since this quadrant contains positive tangents. The point Q will make an angle of β with the x -axis. This angle will be the same as α , so β .

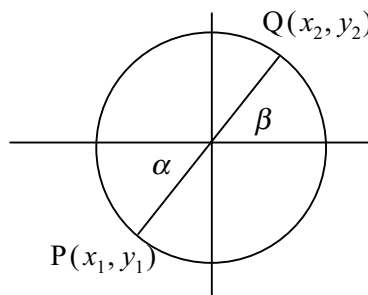

The point Q will have similar coordinates to P except both coordinates will be positive. Notice the equivalent angles that are formed.

Since the original angle was 250° , the angle α will be $250^\circ - 180^\circ = 70^\circ$. Angle β will also be 70° . So the angle with the same tangent as 250° will be 70° . Check this on the calculator. $\tan 70^\circ = 2.7475$.

The coordinates of Q will be $x = \cos 70^\circ = 0.3420$
 $y = \sin 70^\circ = 0.9397$

Activity 8.24

Find angles that have the same tangent as the ones below by doing the following:

1. Consider the angle 290° .
 - (a) Place the angles in a unit circle.
 - (b) Find the size of the **acute** angle (angle less than 90°) formed with the x -axis.
 - (c) Find another quadrant that has the tangent with the same sign.
 - (d) Find a point Q, on the circle in this quadrant that makes an angle with the same tangent.
 - (e) Calculate the coordinates of Q.
2. Consider the angle 50° .
 - (a) Place the angles in a unit circle.
 - (b) Find another quadrant that has the tangent with the same sign.
 - (c) Find a point Q, on the circle in this quadrant that makes an angle with the same tangent.
 - (d) Calculate the coordinates of Q.

As you may have guessed, the tangent function does not look like the sine and cosine functions. There are a few features that you should already be familiar with:

- A vertical asymptote occurs when the angle is 90° (tan is undefined).
- $\tan 270^\circ$ is also undefined so another asymptote occurs here.
- Between 90° and 180° the tan is negative.
- Between 180° and 270° the tan is positive.

Let's look at another feature. What happens when the angle is **just** over 90° ? Find the tan of the following angles.

α	$\tan \alpha$
94°	-14.3
93°	-19.08
92°	-28.64
91°	-57.29
90.001°	-57295.78

As with the tangent of angles less than but close to 90° , the tangent values get larger and negative the closer the angle gets to 90° , but this time the numbers are negative.

Use your knowledge of tangent and the tangent of angles you have already calculated to sketch the function $y = \tan \alpha$ from $0 < \alpha < 360^\circ$, on the graph you sketched previously.

It should look like the figure below:

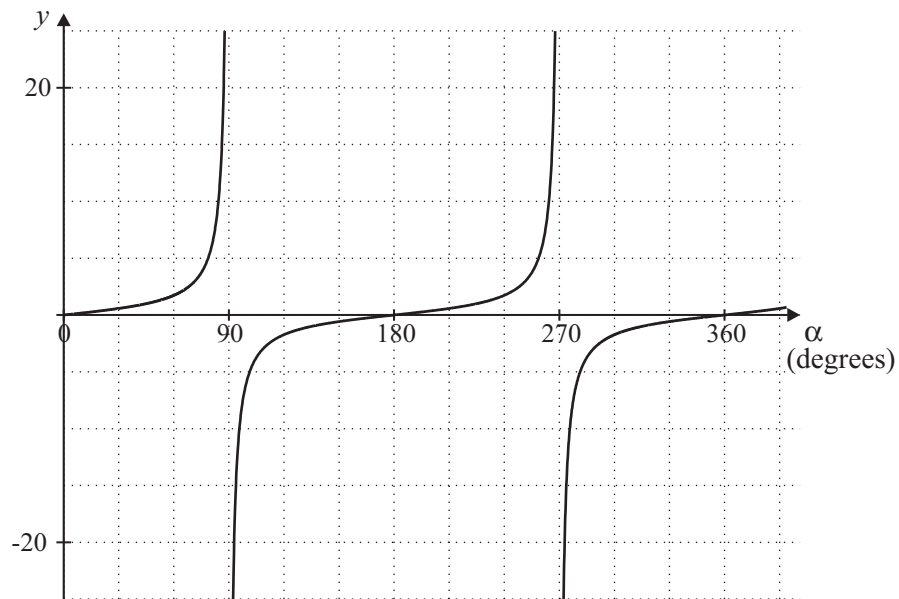

Activity 8.25

On your own graph paper, or on a graphing package, plot the function $y = \tan \theta$ for the domain $-360^\circ < \theta < 360^\circ$.

(The solution should be quite detailed about 5 cm for + y axis.)

8.3.3 The inverse of the tangent function

Just like the sine and cosine functions, there is an inverse to the tangent function. Remember $\cos^{-1} 0.4 = \theta$ means the angle θ has a cos of 0.4. This is similar for the tangent function. There should be a \tan^{-1} button usually above the tan button. Press 0.4 then the \tan^{-1} button. This should give you the answer (correct to 8 or 9 decimal places) of 21.80140949° . To find other angles with the same tangent, we follow the steps as with the sin function. There is no need to sketch the graph, but by doing so it emphasises the relationship between the function, the graph and the inverse.

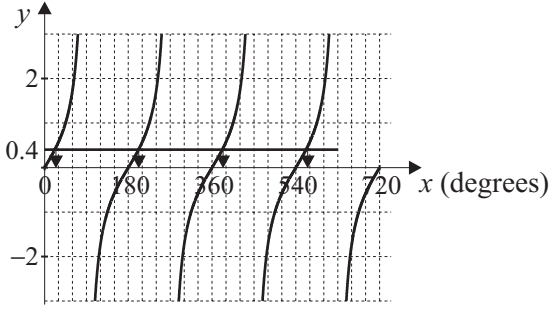
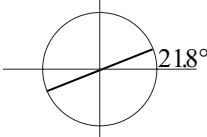
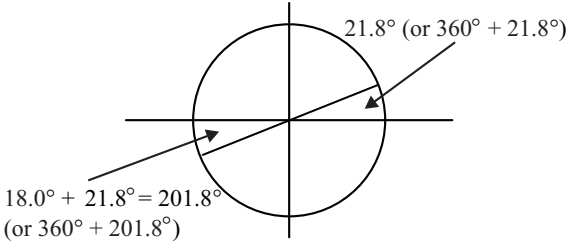
<p>Step 1 Find the angle in the first quadrant using a calculator.</p>	$\tan^{-1} 0.4 \approx 21.80140949$		
<p>Step 2 Draw a quick sketch of the tan curve to see which other angles give this same tan value.</p>			
<p>Step 3 Decide which quadrant the other angle is in.</p>	<table style="width: 100%; text-align: center; border-collapse: collapse;"> <tr> <td style="border-right: 1px solid black; padding: 10px;">2nd quadrant (sin is positive)</td> <td style="padding: 10px;">1st quadrant (sin is positive)</td> </tr> </table>	2nd quadrant (sin is positive)	1st quadrant (sin is positive)
2nd quadrant (sin is positive)	1st quadrant (sin is positive)		
<p>Step 4 Sketch a circle; put in the angle from step 1. Locate the angle in the other quadrant.</p>			
<p>Step 5 Find the size of the angle.</p>	<p>Tan of $(180 + 21.8)$ 201.8° will be the same as the tangent of 21.8°</p>		
<p>Step 6 Indicate other co-terminal points if necessary. Check this with the graph you drew previously.</p>			
<p>Final Step Check your answer. (this is 0.4 correct to 4 decimal places)</p>	<p> $\tan 21.8^\circ \approx 0.399971$ $\tan 201.8^\circ \approx 0.399971$ $\tan 381.8^\circ \approx 0.399971$ $\tan 561.8^\circ \approx 0.399971$ </p>		

Example

Find $\tan^{-1}(-4.0)$ between 0° and 360° , using your graph of the tangent function and then your calculator and the unit circle (correct to the nearest degree).

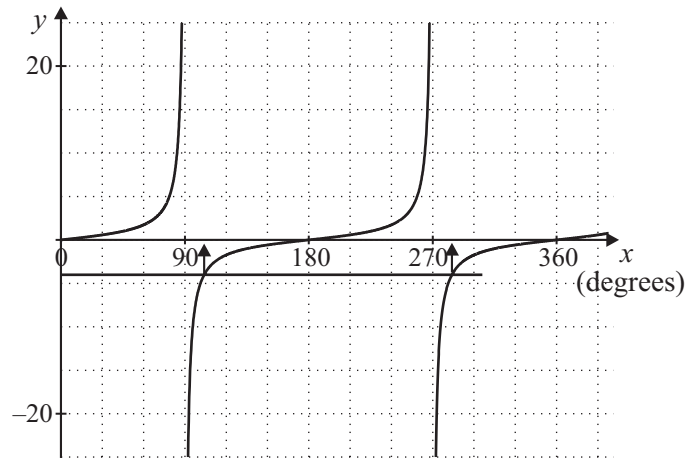

$$\tan^{-1} - 4.0 \approx -76^\circ$$

Tan is negative in the 2nd and 4th quadrants.

Tan -76° is co-terminal with $360^\circ - 76^\circ$.

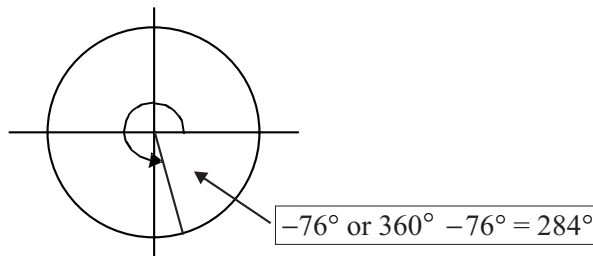

The other angle will be in the 2nd quadrant.

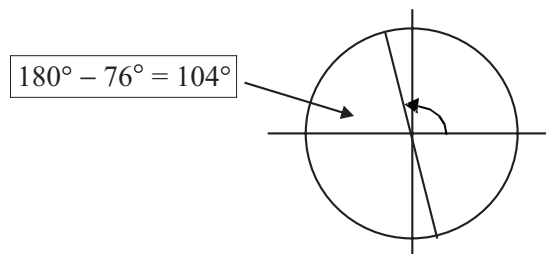

This angle will be $180^\circ - 76^\circ = 104^\circ$

Check:

$$\tan 284^\circ \approx -4.011$$

$$\tan 104^\circ \approx -4.011$$

Activity 8.26

- Using your graph of the tangent function, find approximate angles that have the following tangents:
 - 0.4
 - 2
 - 7.3
 - 0.8
 - 0.4
 - 1.8
- Find the angles in the specified domain that have the following tangents (you may like to use the unit circle to help decide all angles involved):
 - 0.3057 (from 0° to -360°)
 - 0.9004 (from 180° to 450°)
 - 0.0524 (from -90° to 90°)
 - 1 (from 0° to 360°)
 - 14.30 (from -180° to -450°)

8.3.4 Amplitude

Look at the graph of:

$y = 0.5 \tan \theta$ compared to the graph of $y = \tan \theta$

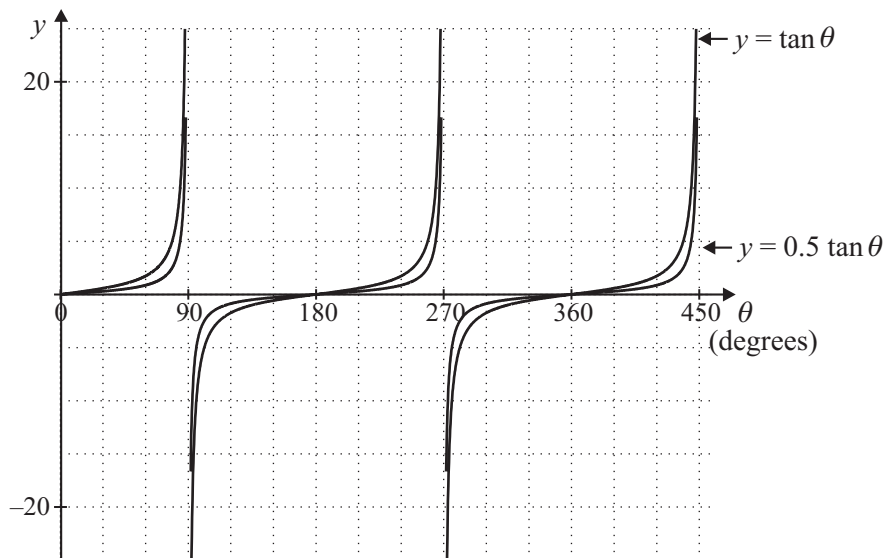

Since it is not a wave, there is no amplitude for a tangent function, but it is important to see what happens to the functions as you change the coefficient of the tan function. In this case the graph of $y = 0.5 \tan \theta$ is similar in shape to $y = \tan \theta$ but as θ approaches 90° , the graph is increasing much more slowly (half the $\tan \theta$ function).

Activity 8.27

1. (a) Draw the graph of the following functions on the same graph paper using the domain $90^\circ \leq \theta \leq 90^\circ$.
 - (i) $y = 4 \tan \theta$
 - (ii) $y = 0.25 \tan \theta$
- (b) Write a sentence comparing the graphs you drew in (a).

8.3.5 Period

In section 8.1.6 we described the sine curve as periodic since a section of the curve could be identified as being repeated – in this case a wave. The tangent curve does not have this characteristic wave motion, but it does repeat. Can you see that the period of $y = \tan \alpha$ is 180° ? The section between 0° and 180° is repeated, or you could say the section between 90° and 270° is repeated. It doesn't matter where you view the graph, the period is still 180° .

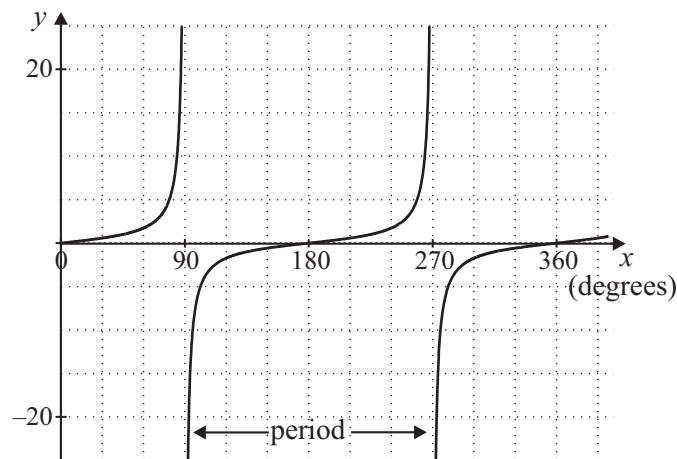

Activity 8.28

1. Look at the periodic functions below and determine the period.

(a)

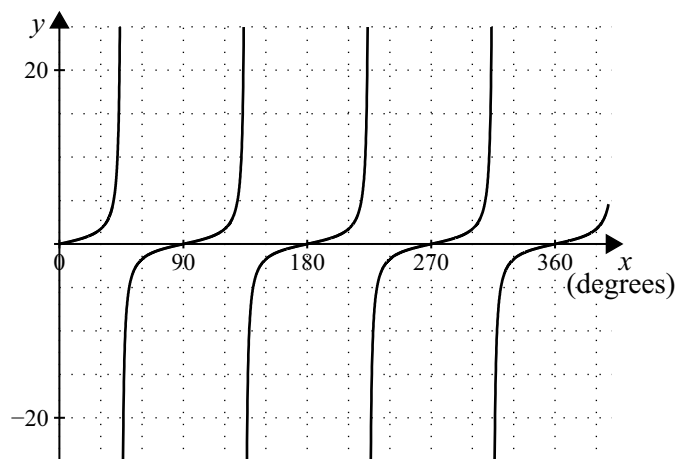

(b)

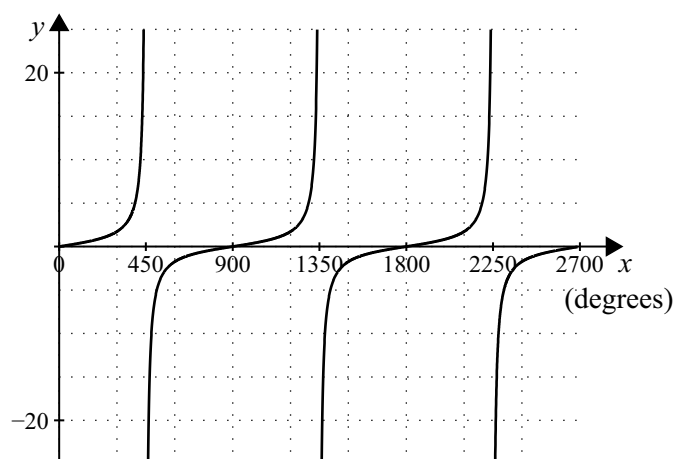

(c)

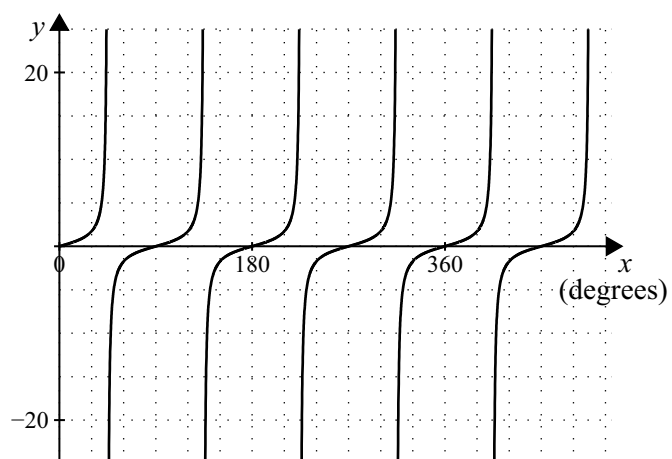

8.4 Putting it all together

In the previous sections you have probably noted a lot of similarity between sine, cosine and tangent ratios and functions. In this section we will see a few examples of how they are connected. We will also use this section to revise some of the concepts you have learnt.

Since these three ratios can all be seen in terms of three sides of a right-angled triangle, it is not surprising that they can be linked in equations. These equations are called *identities*. (Since they are true for all values of the variables.) We will investigate just a few of these.

8.4.1 Tangent ratio

The tangent ratio can be expressed in terms of the sine and cosine ratios.

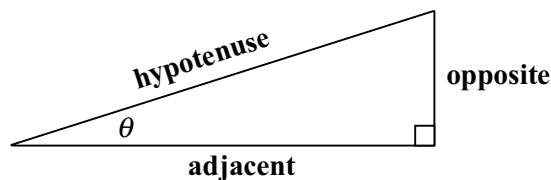

$$\sin \theta = \frac{\text{opposite}}{\text{hypotenuse}}$$

Rearranging the equation we get:

$$\Rightarrow \text{opposite} = \sin \theta \times \text{hypotenuse} \quad \leftarrow \text{equation 1}$$

$$\cos \theta = \frac{\text{adjacent}}{\text{hypotenuse}}$$

$$\Rightarrow \text{adjacent} = \cos \theta \times \text{hypotenuse}$$

$$\tan \theta = \frac{\text{opposite}}{\text{adjacent}}$$

\leftarrow equation 2

substituting (1) and (2) into the equation above:

$$\tan \theta = \frac{\sin \theta \times \text{hypotenuse}}{\cos \theta \times \text{hypotenuse}}$$

$$\tan \theta = \frac{\sin \theta}{\cos \theta}$$

Have you seen this symbol (\Rightarrow) before? It's an implication symbol. It is sometimes used in more formal mathematics to link to the line above.

So if $a = \frac{b}{c}$ then that would imply

$$ac = b \text{ or } \frac{a}{b} = \frac{1}{c} \text{ etc.}$$

Can you also see this can be derived from the unit circle?

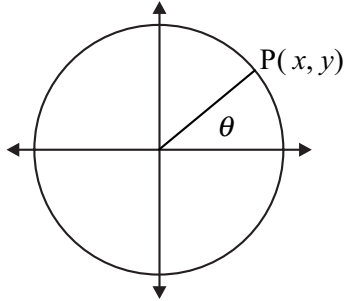

Recall:

$$x = \cos \theta$$

$$y = \sin \theta$$

$$\tan \theta = \frac{y}{x} = \frac{\sin \theta}{\cos \theta}$$

Example

If $\sin \alpha = \frac{3}{5}$, and $\cos \alpha = \frac{4}{5}$, find $\tan \alpha$

$$\begin{aligned} \tan \alpha &= \frac{\sin \alpha}{\cos \alpha} \\ &= \frac{3}{5} \div \frac{4}{5} \\ &= \frac{3}{5} \times \frac{5}{4} \\ &= \frac{3}{4} \end{aligned}$$

Activity 8.29

1. If $\sin \beta = \frac{5}{13}$, and $\cos \beta = \frac{12}{13}$, find $\tan \beta$.
2. If $\sin \alpha = \frac{1}{2}$ and $\cos \alpha = \frac{\sqrt{3}}{2}$, find $\tan \alpha$.
3. If $\tan \theta = 0.4040$ and $\cos \theta = 0.9272$, find $\sin \theta$.

Example

A biologist wants to calculate the number of insects on a pond and wishes to take a surface sample area. She is in a boat and has a length of string. She throws the string out of the boat so that it makes an angle of 52° with the edge of the boat and uses 4 metres of string. Supposing she wanted to replicate this collection at another site she must get the exact coordinates in relation to the boat so she could. What would be the coordinates of the end of the string?

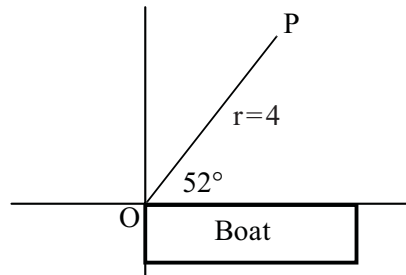

In the diagram above, the point P is 4 units from the origin and the line OP makes an angle of 52° with the x axis.

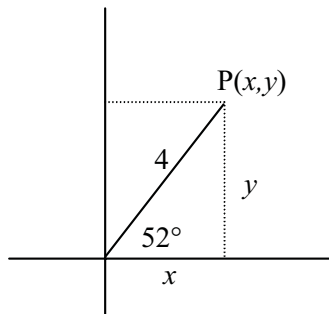

In the diagram above, P is the point (x, y) . However we also know that:

$$x = r \cos \theta \text{ and}$$

$$y = r \sin \theta$$

$$\begin{aligned} x &= 4 \cos 52^\circ \\ x &\approx 4 \times 0.6157 \\ &\approx 2.46 \end{aligned}$$

$$\begin{aligned} y &= 4 \times \sin 52^\circ \\ &\approx 4 \times 0.7880 \\ &\approx 3.15 \end{aligned}$$

So the coordinates of the end of the string will be $(2.46, 3.15)$.

If the point was $(4,3)$ how long would the string be and at what angle would she have to throw the string?

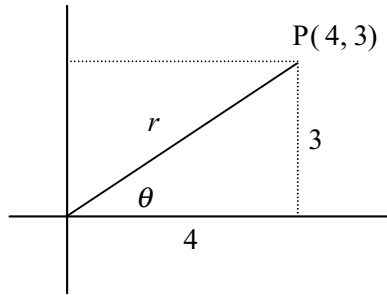

If r is the length of the string and θ is the angle, then:

$$\begin{aligned} r &= \sqrt{x^2 + y^2} \\ &= \sqrt{16 + 9} \\ &= 5 \end{aligned}$$

$$\begin{aligned} \tan \theta &= \frac{y}{x} \\ &= \frac{3}{4} \\ &\approx 0.75 \end{aligned}$$

$$\theta \approx 36.87^\circ$$

So the string would be 5 metres long and would be thrown at an angle to the boat of about 37° .

A position described by its angle and distance from the origin is said to be in **Polar Coordinates**. If you go on to do more mathematics you may come across points described in this way. However you do not need to learn Polar coordinates formally in this unit.

8.4.2 Pythagoras' identity

The three trigonometric ratios can be expressed in an equation, developed from Pythagoras' theorem.

Recall that in a right angled triangle:

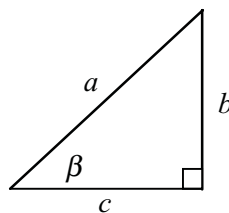

Pythagoras' Theorem says:

$$b^2 + c^2 = a^2 \quad \longleftarrow \text{equation 1}$$

but:

$$\begin{aligned} \sin \beta &= \frac{b}{a} \\ \Rightarrow b &= a \sin \beta \end{aligned}$$

$$\begin{aligned} \cos \beta &= \frac{c}{a} \\ \Rightarrow c &= a \cos \beta \end{aligned}$$

substituting for b and c into equation 1

$$a^2 = a^2 \sin^2 \beta + a^2 \cos^2 \beta$$

$$a^2 = a^2 (\sin^2 \beta + \cos^2 \beta)$$

$$1 = \sin^2 \beta + \cos^2 \beta$$

Applying the distributive law.

Dividing both sides by a squared.

$$\boxed{\sin^2 \beta + \cos^2 \beta = 1}$$

We call this the Pythagorean Identity.

Example

If $\sin \alpha = 0.25$, find $\cos \alpha$.

$$\sin^2 \alpha + \cos^2 \alpha = 1$$

$$0.25^2 + \cos^2 \alpha = 1$$

$$\cos^2 \alpha = 1 - 0.25^2$$

$$= 1 - 0.0625$$

$$= 0.9375$$

$$\cos \alpha = \pm \sqrt{0.9375}$$

$$\approx \pm 0.9682$$

Remember: if the sine of an angle is positive then the cos of that angle can be positive or negative. Sin and cos are both positive in the first quadrant. Sin is positive and cos is negative in the second quadrant.

Note: The notation for squaring a sine is: $\sin^2 \alpha$. It can also be written as $(\sin \alpha)^2$. Remember $\sin^2 \alpha = \sin \alpha \times \sin \alpha$

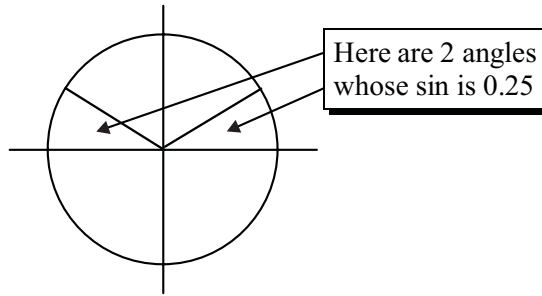

Activity 8.30

1. If $\sin \theta = -0.5$, find $\cos \theta$
2. If $\cos \alpha = 0.7071$, find $\sin \alpha$.
3. Given the value of $\sin x = 0.6428$, find the values of $\cos x$ and $\tan x$ without using the trigonometric buttons on the calculator. Check your results on the calculator.

These are only two identities in trigonometry. There are many more you will come across as you study more trigonometry. These identities are important in solving and simplifying trigonometric equations.

Note: There has been some new notation developed in this module that can be quite confusing. Make sure you are clear on the notation used.

$\sin^{-1} x = \theta$, means what angle gives you a sine of x .

This statement is the same as $\sin \theta = x$.

This notation is somewhat confusing since it looks similar to $(\sin x)^{-1}$ and $\sin x^{-1}$.

Remember:

$$(\sin x)^{-1} = \frac{1}{\sin x}$$

$\sin^{-1} x$ is the notation for the inverse of \sin .

$\sin x^{-1}$ means the $\sin \frac{1}{x}$

$\sin^2 x$ means $\sin x \times \sin x$

$(\sin x)^2$ also means $\sin x \times \sin x$

$\sin x^2$ means the \sin of an angle x^2

This is the same for \cos and \tan as well.

Example

Find:

What are the meaning of $\cos^{-1} 0.45$, $\cos(0.45^\circ)^{-1}$ and $(\cos 0.45^\circ)^{-1}$? Explain in your own words and find the values of each expression.

$\cos^{-1} 0.45$ means to find an angle whose cosine is 0.45

$$\cos^{-1} 0.45 = 63.256^\circ$$

$$\begin{aligned} \cos(0.45^\circ)^{-1} \text{ means } \cos \frac{1}{0.45^\circ} \\ \approx \cos 2.22 \\ \approx 0.99925 \end{aligned}$$

$(\cos 0.45^\circ)^{-1}$ means find the cosine of an angle 0.45° and then find the reciprocal of this value.

$$\begin{aligned} (\cos 0.45^\circ)^{-1} &= \frac{1}{\cos 0.45^\circ} \\ &= \frac{1}{0.9999} \\ &= 1.000 \end{aligned}$$

Activity 8.31

Evaluate:

- (a) $(\sin 20^\circ)^{-1}$
- (b) $\cos 1.4^{-1}$
- (c) $\tan^2 120^\circ$
- (d) $\sin 1.2^2$
- (e) $(\cos 31.4^\circ)^{-1}$

We have touched on solving trigonometric equations. If you go on to do more mathematics, you will find more of these trigonometric relationships. A very famous one developed by Jean Baptiste Fourier (1768–1830) showed almost any function over a given interval can be represented by a trigonometric series in the form:

$$f(x) = a_0 + a_1 \cos x + a_2 \cos 2x + a_3 \cos 3x \dots$$

This theorem is one of the great achievements of 19th century analysis. Sine and cosine functions are essential to the study of ALL periodic phenomena – ‘the building blocks...in much the same way the prime numbers are the building blocks of all integers’ (Maor 1998, p. 54). It is important in optics and acoustics, information theory and quantum mechanics.

That's the end of this module. For most of you, there has been a lot of new terminology used, as well as new ways of seeing angles. As most of you will be undertaking more mathematics in your future studies, it is important that you understand this module well.

Before you are really finished, you should do a number of things:

- You have now almost finished the material in this course. How has your action plan for study gone? Do you need to contact your tutor to discuss any delays or concerns?
- Have you made a summary of the important points in this module? Have you added new words to your glossary? Go back over these now to make sure they are complete.
- Practice some real world problems in 'A taste of things to come'.
- Check your skill level by attempting the post-test.
- When you are ready, complete and submit your assignment.

8.5 A taste of things to come

1. Projectile motion refers to the motion of an object projected into the air at an angle, such as throwing a football or an athlete doing long jump. Galileo found that projectile motion could be analysed by breaking it into two parts – horizontal and vertical components – which could then be treated independently of each other.

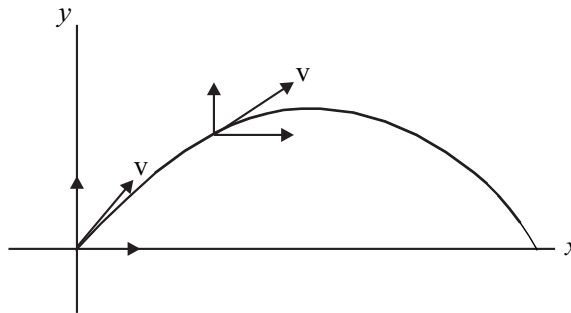

In artillery engineering it was important to know the projectile range of a cannon. Using Galileo's method of analysis of projectiles, it can be shown that (neglecting air resistance) the range of a cannon is given by the formula:

$$R = \frac{v_0^2 \sin 2\theta}{g} \text{ where,}$$

v_0 is the velocity of the projectile as it leaves the cannon

θ is the angle of firing in relation to the ground

g is the acceleration due to gravity ($\approx 9.81 \text{ m/sec}^2$).

It is evident from this formula that for a given velocity the range depends solely on θ . It reaches its maximum when $\theta = 45^\circ$.

A seventeenth century king used four cannons to protect his castle from attack. Enemy attack could only come from the north because a river and mountain range provided natural protection from all other directions. The location of the cannons are as shown in the following figure.

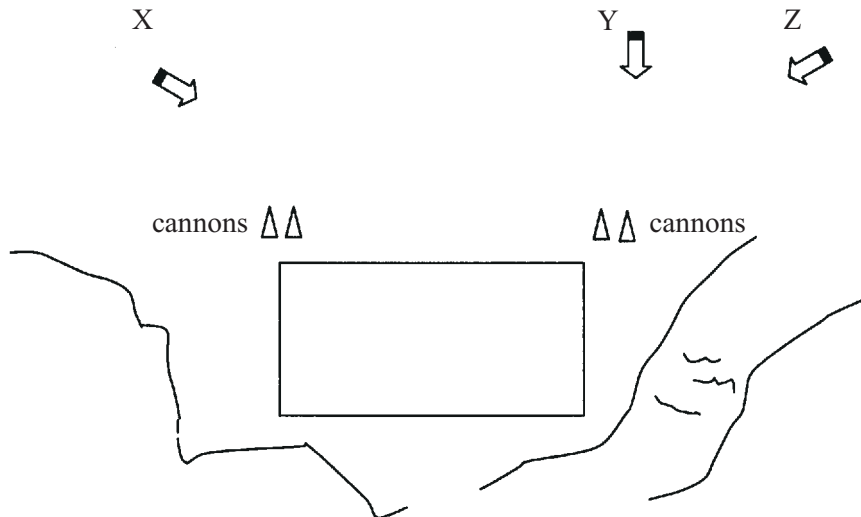

A small scale attack was launched by a neighbouring land owner. The attack came from three directions as shown.

- (a) At what angle should the cannons on the eastern wall be aimed assuming they have a muzzle velocity, v_0 , of 60 m/s to strike:
- target Y which is 160 m away.
 - target Z which is 220 m away.
- (b) Would it be possible for the king to use the cannons on the eastern wall alone to fend off the attack if:
- target X was 400 m away from the cannons
 - target X was 360 m away from the cannons
- (c) As the cannons on the western wall are later models, the king was not sure of the muzzle velocity. He assumed the muzzle velocity was 60 m/s.
- What angle would he set the cannon to strike target X 190 m away?
 - If he overshot the target by 25 m, what was the actual muzzle velocity?

2. When you partially immerse an object such as a ruler or pencil in water it appears to be bent. This is because as light passes from one medium (air) to another (water), it is refracted and its direction is changed. Willebrord Snell (1591–1626) found that the angle of refraction depends on the speed of light of the two media and on the incident angle. This became known as Snell's law which is written

$$n_1 \sin \theta_1 = n_2 \sin \theta_2$$

where,

θ_1 is the angle of incidence

θ_2 is the angle of refraction

n_1 is the refractive index of material 1

n_2 is the refractive index of material 2

If a ray enters a medium where the speed of light is less (i.e. greater refractive index) the ray bends toward the normal and it bends away from the normal if the speed of light is greater (i.e. lower refractive index). Refer to the figure which shows light passing from air to water.

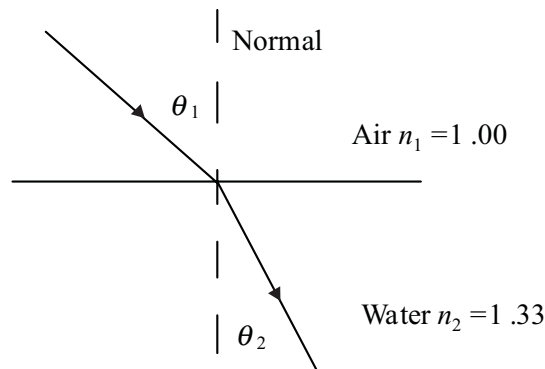

- (a) Light strikes the smooth surface of a swimming pool at an incident angle of 63° , what is the angle of refraction?
- (b) At night the pool is lit by underwater lights. If the incident angle of a ray from one of these lights is 23° , what is the refractive angle?
- (c) Rays from the sun are seen to make a 35° angle to the normal beneath the water. At what angle above the horizon is the sun?

3. Vibrating objects are the source of all sound. Some musical instruments produce sound by vibrating strings, such as the guitar. Other instruments produce sound by vibrating columns of air, such as the flute. When a string of a guitar is plucked, sound waves of a variety of frequencies are produced. Frequency, f , means the number of complete waves passing a particular point each second and is measured in Hertz, Hz.

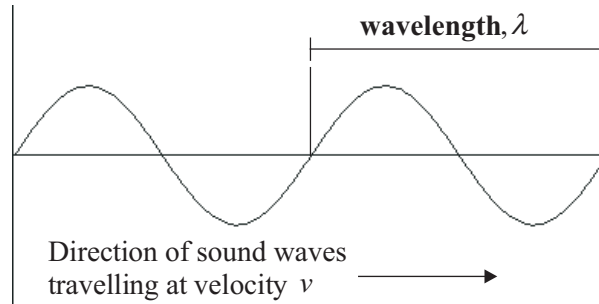

The pitch of the sound produced by a musical instrument is directly related to the frequency of vibration – the higher the frequency, the higher the pitch.

- (a) The diagrams below show the first three natural frequencies of a vibrating string (also, called harmonics). If the length, L , of a guitar string is 0.75 m, what are the wavelengths (i.e. the length of one complete period) of the first three harmonics.

(i)

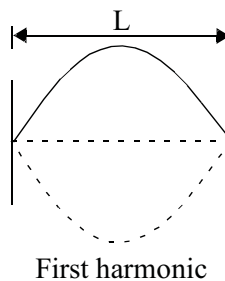

(ii)

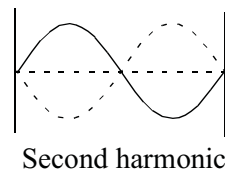

(iii)

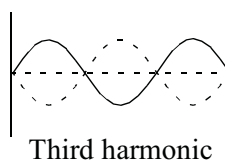

- (b) The velocity, v , of a wave travelling along a guitar string is related to the tension in the string, F_T , and the mass per unit length, μ , of the string as shown in the following formula (μ is the Greek letter mu),

$$v = \sqrt{\frac{F_T}{\mu}}$$

If the guitar string has a mass of 0.003 kg and a tension of 680 N*, find

- (i) μ
- (ii) v
- (c) The frequency of vibration, f , of a wave can be found using the formula (λ is the Greek letter lambda),

$$f = \frac{v}{\lambda} \text{ where,}$$

λ is the wavelength in metres

- (i) What is the frequency of vibration of the first harmonic?
- (ii) What is the frequency of vibration of the second and third harmonics?
- (iii) If the tension of the string was increased, would this increase or decrease the pitch of the sound?

*N is a Newton unit of force in kilograms metres per sec².

8.6 Post-test

1. Solve for the unknown pronumeral in the following.

(a)

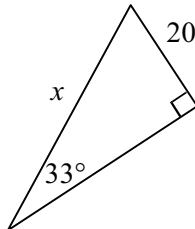

(b)

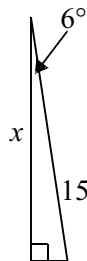

(c)

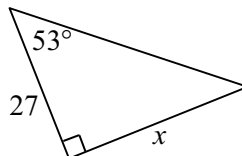

2. Complete the following (without using a calculator).

(a) $\sin \theta^\circ = \underline{\hspace{2cm}}$

(b) $\tan 270^\circ = \underline{\hspace{2cm}}$

(c) $\cos 180^\circ = \underline{\hspace{2cm}}$

3. For each of the following, find θ . Give all solutions between 0° and 360° . (Rounded to one decimal place.)

(a) $\sin \theta = 0.4695$

(b) $\cos \theta = -0.752$

(c) $\tan \theta = 2$

4. Write down a co-terminal angle for

(a) 78°

(b) 245°

5. Convert the following degrees in decimal form to degrees, minutes and seconds.

19.254°

6. Convert the following to degrees in decimal form.

$124^\circ 16' 54''$

7. Find the amplitude and period of the following function.

$$y = 0.5 \cos \frac{x}{3}$$

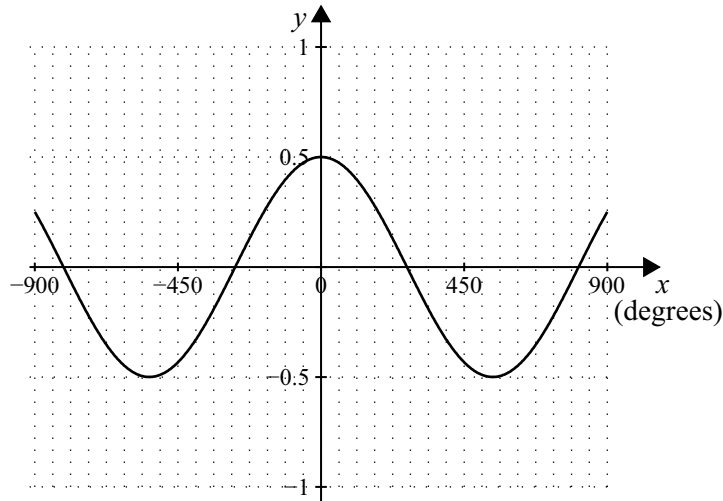

8. Given the value of $\cos x = 0.6381$, find the value of $\sin x$ and $\tan x$ using the Pythagorean and tangent identities.

9. Find:

(a) $\cos 1.4^\circ$

(b) $(\sin 45^\circ)^{-1}$

(c) $(\tan 2.6^\circ)^2$

10. A small plane is flying at an altitude 4000 m above a flight tower and observes the angle of depression to the flight tower is 5.6° . Twenty minutes later the angle is 10.7° . What is the speed of the plane?

11. A surveyor wants to determine the height of a tree from across a river. Using a clinometer and standing directly opposite the tree, the angle of elevation to the top of the tree was measured to be 15.45° . From a point 20 m along the river the angle to the original point of observation and the bottom of the tree was found to be 60° . Find the height of the tree.

8.7 Solutions

Solutions to activities

Activity 8.1

1.

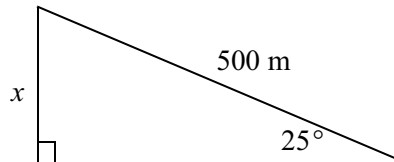

Let x be the height above ground of the missile after it has travelled 500 m.

$$\sin 25^\circ = \frac{\text{opp}}{\text{hyp}}$$

$$\sin 25^\circ = \frac{x}{500}$$

$$500 \times \sin 25^\circ = x$$

$$x = 211.3091$$

Therefore the height above ground of the missile is 211.31 m (correct to two decimal places).

2.

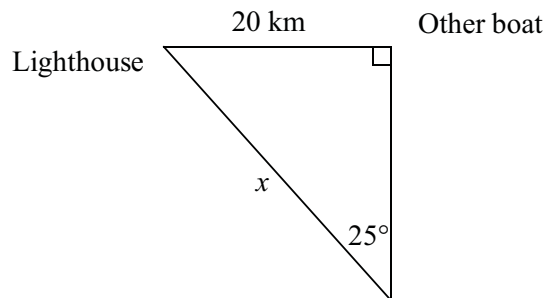

Let x be the distance of Jack and Jill's boat from the lighthouse.

$$\sin 25^\circ = \frac{\text{opp}}{\text{hyp}}$$

$$\sin 25^\circ = \frac{20}{x}$$

$$x \times \sin 25^\circ = 20$$

$$x = \frac{20}{\sin 25^\circ}$$

$$x \approx 47.3240$$

Therefore Jack and Jill's boat is approximately 47.32 km from the lighthouse.

3.

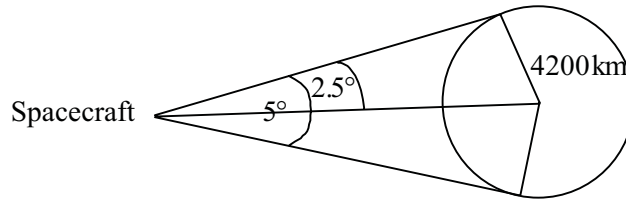

Let x be the shortest distance from the spacecraft to the planet. Let y be the hypotenuse of the triangle.

$$\sin 2.5^\circ = \frac{\text{opp}}{\text{hyp}}$$

$$\sin 2.5^\circ = \frac{4200}{y}$$

$$y = \frac{4200}{\sin 2.5^\circ}$$

$$y \approx 96287.4596$$

Therefore the distance to the centre of the planet is approximately 96287 km. The shortest distance to the surface of the planet is $96287 - 4200 = 92087$ km.

4.

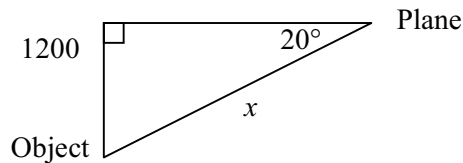

Let x be the distance from the plane to the closest visible point.

$$\sin 20^\circ = \frac{\text{opp}}{\text{hyp}}$$

$$\sin 20^\circ = \frac{1200}{x}$$

$$x \times \sin 20^\circ = 1200$$

$$x = \frac{1200}{\sin 20^\circ}$$

$$x \approx 3508.5653$$

Therefore the distance of the plane from this point is approximately 3509 m.

5. Attempt 1

Great – your diagram is right; you have the right trig. ratio

Your problem is at the line $\sin 25^\circ = \frac{20}{x}$.

To get x you must first multiply both sides by x :

$$x \times \sin 25 = 20$$

Now divide by $\sin 25$

$$x = 20 / \sin 25$$

$$x = 47.324032$$

So Jack and Jill are about 47.32 kilometres from the lighthouse.

Another suggestion is to look at your answer – does it appear right. If you had drawn a diagram approx. to scale (not too accurate) then you would think that 8.45 metres is a bit too small. You also know that the hypotenuse is the longest side of a triangle so your answer must be wrong.

Attempt 2

You have the right answer – well done!

But you should have some working so I can see the way you went about solving the question – maybe it was not the most efficient way.

Also you did not put units in your final answer. Was it 47 metres or kilometres, and does the question suggest you need to be exact. Perhaps you could have said $x = 47.324032$. Then Jack and Jill are about 47 kilometres from the lighthouse.

Attempt 3

You have the right equation $x = 20 / \sin 25^\circ$, but you cannot cancel the 20 and 25. The denominator is not a multiplication – it reads the sine of 25° which you have to work out first then divide it into 20.

$$x = 20 / \sin 25^\circ$$

$$x = 47.324032$$

So Jack and Jill are about 47.32 kilometres from the lighthouse.

Attempt 4

You are right the number is too big. Good to see you are thinking!

You have the ratio right, but what has happened is your calculator is in RAD mode. You need to put your calculator into DEGree mode usually by using the MODE key on your calculator. You should then find the answer to be about 47 kilometres.

Activity 8.2

1. (a)

$$\sin 45^\circ = \frac{y}{r}$$

$$\text{when } r = 1 \quad \sin 45^\circ = \frac{y}{1}$$

$$y = \sin 45^\circ$$

$$y \approx 0.7071$$

(b)

$$\sin 15^\circ = \frac{y}{r}$$

$$\text{when } r = 1 \quad \sin 15^\circ = \frac{y}{1}$$

$$y = \sin 15^\circ$$

$$y \approx 0.2588$$

(c)

$$\sin 85^\circ = \frac{y}{r}$$

$$\text{when } r = 1 \quad \sin 85^\circ = \frac{y}{1}$$

$$y = \sin 85^\circ$$

$$y \approx 0.9962$$

(d)

$$\sin 2.5^\circ = \frac{y}{r}$$

$$\text{when } r = 1 \quad \sin 2.5^\circ = \frac{y}{1}$$

$$y = \sin 2.5^\circ$$

$$y \approx 0.0436$$

Activity 8.3

1. (a)

θ	$\sin \theta$
0°	0
90°	1
180°	0
270°	-1
360°	0

(b) Sine is positive in the **first and second** quadrants.Sine is negative in the **third and fourth** quadrants.

2.

α	Quadrant	Sign(\pm)	$\sin \alpha$
125°	2nd	+	0.8192
160°	2nd	+	0.3420
189°	3rd	-	-0.1564
235°	3rd	-	-0.8192
280°	4th	-	-0.9848
320°	4th	-	-0.6428
350°	4th	-	-0.1736
390°	1st	+	0.5

Activity 8.4

1. (a) (i)

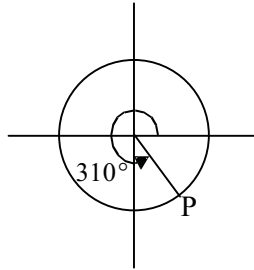

(ii) $y = \sin 310^\circ \approx -0.7660$

(iii)

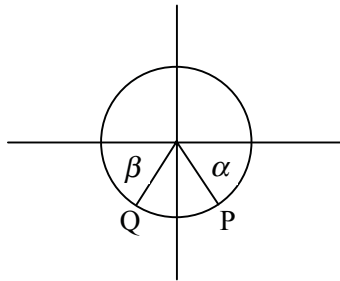

(iv) Since the original angle was 310° , the angle α will be $360^\circ - 310^\circ = 50^\circ$. Angle β will also be 50° . So the angle that will have the same sine as 310° will be $180^\circ + 50^\circ = 230^\circ$. (Check $\sin 230^\circ \approx -0.7660$)

(b) (i)

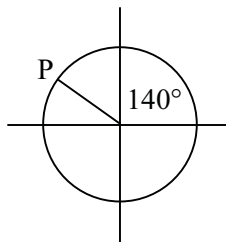

(ii) $y = \sin 140^\circ \approx 0.6428$

(iii)

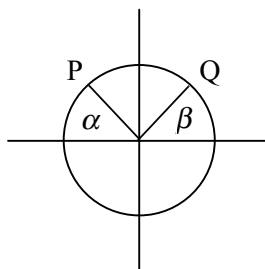

(iv) Since the original angle was 140° , the angle α will be $180^\circ - 140^\circ = 40^\circ$. Angle β will also be 40° . So the angle with the same sine as 140° will be $0^\circ + 40^\circ = 40^\circ$.

Activity 8.5

1.

α	$\sin \alpha$	Angles as multiples of 360°	Other co-terminal angles
520°	0.3420	$360^\circ \times 1 + 160^\circ$	$160^\circ, 880^\circ, 1240^\circ$
600°	-0.8660	$360^\circ \times 1 + 240^\circ$	$240^\circ, 960^\circ, 1320^\circ$
650°	-0.9397	$360^\circ \times 1 + 290^\circ$	$290^\circ, 1010^\circ, 1370^\circ$
800°	0.9848	$360^\circ \times 2 + 80^\circ$	$80^\circ, 440^\circ, 1160^\circ$

2.

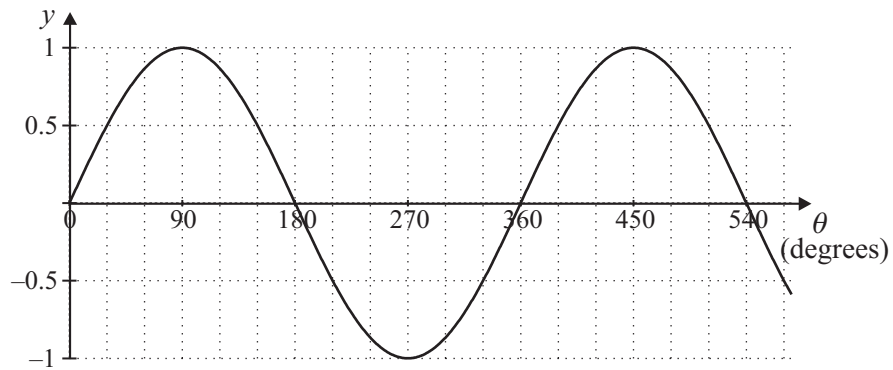

Activity 8.6

- (a) $\theta \approx 13^\circ, 167^\circ, -193^\circ \dots$
- (b) $\theta \approx 79^\circ, 101^\circ, -259^\circ \dots$
- (c) $\theta \approx 189^\circ, 351^\circ, -9^\circ \dots$
- (d) $\theta \approx 213^\circ, 327^\circ, -33^\circ \dots$

Activity 8.7

(a)

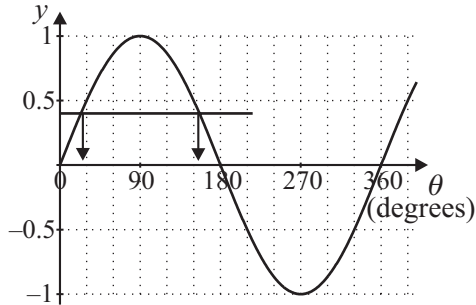

$$\theta = \sin^{-1} 0.4225$$

$$\theta \approx 25^\circ$$

Sin is positive in the 1st and 2nd quadrants

$$\theta = 25^\circ \text{ or } 155^\circ$$

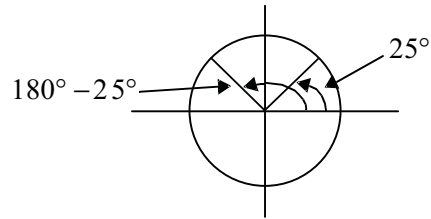

(b)

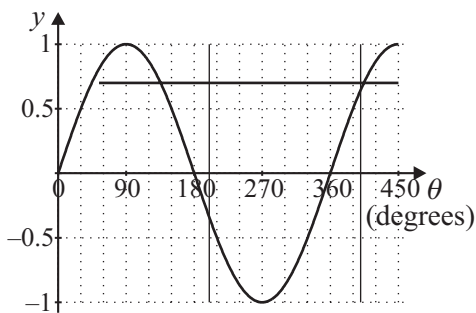

$$0.7124 \text{ (from } 200^\circ \text{ to } 400^\circ)$$

$$\theta = \sin^{-1} 0.7124$$

$$\theta \approx 45^\circ$$

Since the domain is between 200° and 400° , and sine is positive in the first and second quadrants, then no solutions can be found within this range.

(c)

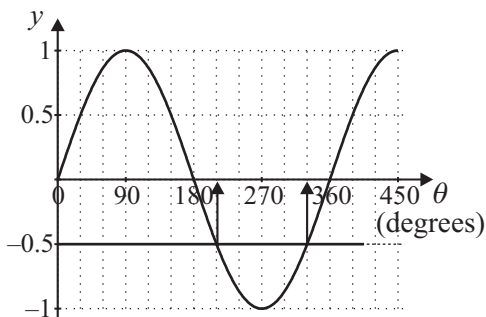

$$-0.5 \text{ (from } 200^\circ \text{ to } 400^\circ)$$

$$\theta = \sin^{-1} (-0.5)$$

$$\theta \approx -30^\circ$$

Since the domain is between 200° and 400° and sine is negative in the third and fourth quadrants, then the angles must be 210° and 330° .

(d)

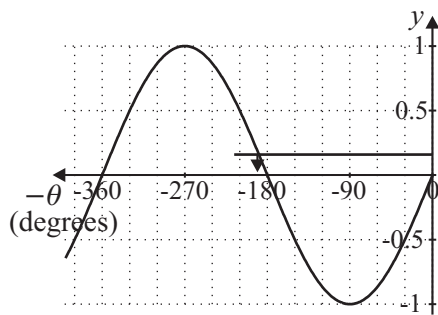

0.1564 (from 0° to -270°)

$$\theta = \sin^{-1} 0.1564$$

$$\theta \approx 9^\circ$$

Since the domain is between 0° and -270° and sine is positive in the first and second quadrants, then the angle must be -189° .

(e)

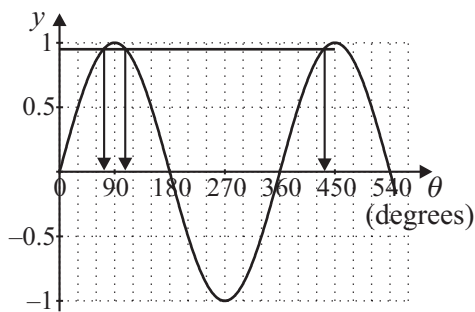

0.9511 (from 50° to 450°)

$$\theta = \sin^{-1} 0.9511$$

$$\theta \approx 72^\circ$$

Since the domain is between 50° and 450° and sine is positive in the first and second quadrants, then the angles must be 72° , 108° , 432° .

(f)

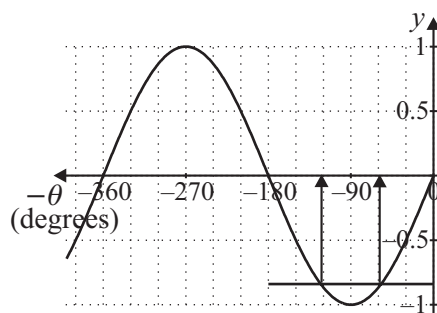

-0.8387 (from 0° to -360°)

$$\theta = \sin^{-1} (-0.8387)$$

$$\theta \approx -57^\circ$$

Since the domain is between 0° and -360° and sine is negative in the third and fourth quadrants, then the angles must be -57° and -123° .

Activity 8.81. (a) 36.8699° Converting decimal to minutes, $0.8699 \times 60 = 52.194$ minutesConverting decimal to seconds, $0.194 \times 60 = 11.64$ secondsTherefore, $36.8699 = 36^\circ 52' 11.64''$ (Check on calculator.)(b) 8.2150° Converting decimal to minutes, $0.2150 \times 60 = 12.9$ minutesConverting decimal to seconds, $0.9 \times 60 = 54$ secondsTherefore, $8.2150^\circ = 8^\circ 12' 54''$ (c) 128.0208° Converting decimal to minutes, $0.0208 \times 60 = 1.248$ minutesConverting decimal to seconds, $0.248 \times 60 = 14.88$ secondsTherefore, answer = $128^\circ 1' 14.88''$ 2. (a) $22^\circ 14' 56''$ The quickest way to do this is to convert $14' 56''$ to seconds first, and then to divide by 60×60 .

$$14' 56'' = \frac{14 \times 60 + 56}{60 \times 60} \approx 0.2489^\circ.$$

Therefore, $22^\circ 14' 56'' \approx 22.2489^\circ$ (b) $4^\circ 29' 33''$

$$29' 33'' = \frac{29 \times 60 + 33}{60 \times 60} = 0.4925^\circ$$

Therefore, $4^\circ 29' 33'' = 4.4925^\circ$ (c) $285^\circ 05' 20''$

$$5' 20'' = \frac{5 \times 60 + 20}{60 \times 60} \approx 0.0889$$

Therefore, $285^\circ 05' 20'' \approx 285.0889^\circ$

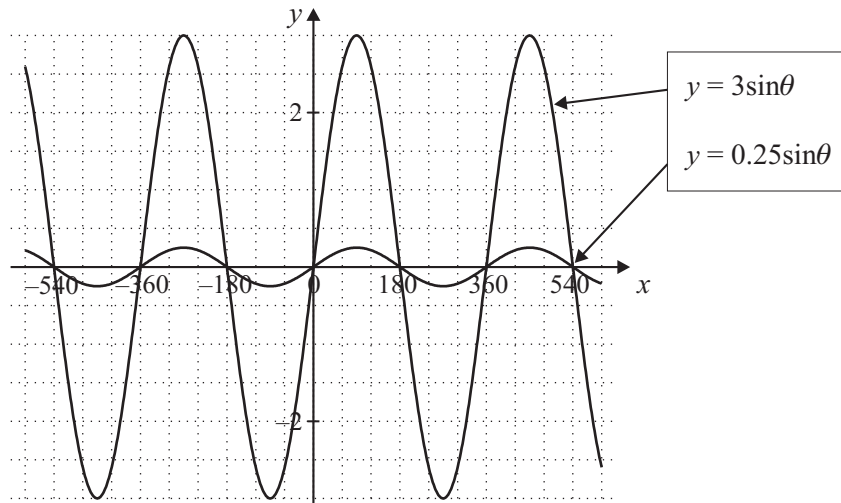
Activity 8.9**Activity 8.10**

- (a) Amplitude = 4
- (b) Amplitude = 0.5
- (c) Amplitude = 0.5

Activity 8.11

- (a) period = 90°
- (b) period = 120°
- (c) period = 1800°

Activity 8.12

1. (a) and (c) are correct as they are complementary angles but (b) is incorrect as the sum of the angles is 100° not 90° .
2. (a) $\theta = 65^\circ$ as this is the complementary angle
 (b) $\theta = 17^\circ$ as this is the complementary angle.

Activity 8.13

1.

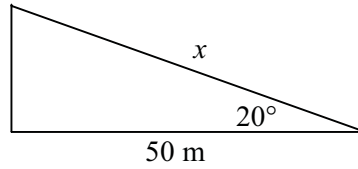

Let x be the length of the cable in metres

$$\cos 20^\circ = \frac{\text{adj}}{\text{hyp}}$$

$$\cos 20^\circ = \frac{50}{x}$$

$$x \cos 20^\circ = 50$$

$$x = \frac{50}{\cos 20^\circ}$$

$$x \approx 53.2089$$

Therefore approximately 53.21 m of cable would be required to span this distance.

2.

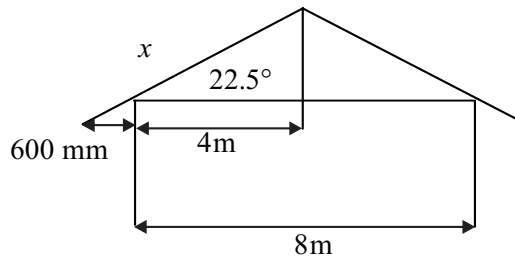

Let x be the length of the rafter in metres.

$$\cos 22.5^\circ = \frac{\text{adj}}{\text{hyp}}$$

$$\cos 22.5^\circ = \frac{4.6}{x}$$

$$x \cos 22.5^\circ = 4.6$$

$$x = \frac{4.6}{\cos 22.5^\circ}$$

$$x \approx 4.9790$$

Therefore the rafter length required is 4.979 m.

3.

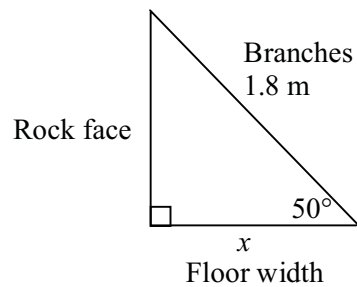

Let x be the floor width in metres

$$\cos 50^\circ = \frac{\text{adj}}{\text{hyp}}$$

$$\cos 50^\circ = \frac{x}{1.8}$$

$$1.8 \cos 50^\circ = x$$

$$x \approx 1.157$$

Therefore the floor width available is 1.157 m.

Activity 8.14

1. (a) $\cos 45^\circ = \frac{x}{r}$

$$\cos 45^\circ = \frac{x}{1}$$

$$x = \cos 45^\circ$$

$$x \approx 0.7071$$

(b) $\cos 73^\circ = \frac{x}{r}$

$$\cos 73^\circ = \frac{x}{1}$$

$$x = \cos 73^\circ$$

$$x \approx 0.2924$$

(c) $\cos 7^\circ = \frac{x}{r}$

$$\cos 7^\circ = \frac{x}{1}$$

$$x = \cos 7^\circ$$

$$x \approx 0.9925$$

$$\begin{aligned} \text{(d) } \cos 30^\circ &= \frac{x}{r} \\ \cos 30^\circ &= \frac{x}{1} \\ x &= \cos 30^\circ \\ x &\approx 0.8660 \end{aligned}$$

Activity 8.15

1. (a)

θ	$\cos \theta$
0°	1
90°	0
180°	-1
270°	0
360°	1

(b) Cosine is positive in the **first and fourth** quadrants.Cosine is negative in the **second and third** quadrants.

2.

α	Quadrant	Sign(\pm)	$\cos \alpha$
125°	2nd	-	-0.5736
160°	2nd	-	-0.9397
189°	3rd	-	-0.9877
235°	3rd	-	-0.5736
280°	4th	+	0.1736
320°	4th	+	0.7660
350°	4th	+	0.9848
390°	1st	+	0.8660
520°	2nd	-	-0.9397
600°	3rd	-	-0.5
650°	4th	+	0.3420
-250°	2nd	-	-0.3420
-200°	2nd	-	-0.9397
-100°	3rd	-	-0.1736

Activity 8.16

1. (a) (i)

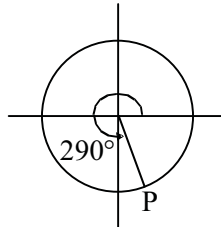

(ii) $x = \cos 290^\circ = 0.3420$

(iii)

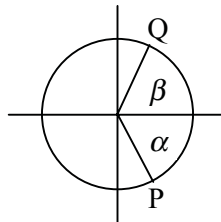

(iv) Since the original angle was 290° , the angle α will be $360^\circ - 290^\circ = 70^\circ$. Angle β will also be 70° . So the angle with the same cos as 290° will be $0^\circ + 70^\circ = 70^\circ$.

(b) (i)

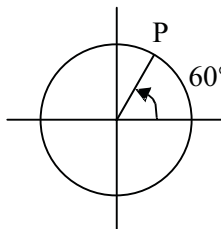

(ii) $x = \cos 60^\circ = 0.5$

(iii)

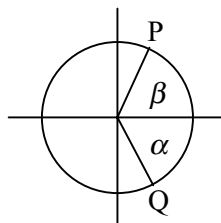

(iv) Since the original angle was 60° , the angle α will $360^\circ - 60^\circ = 300^\circ$. So the angle with the same cos as 60° will be 300° .

2. (a)

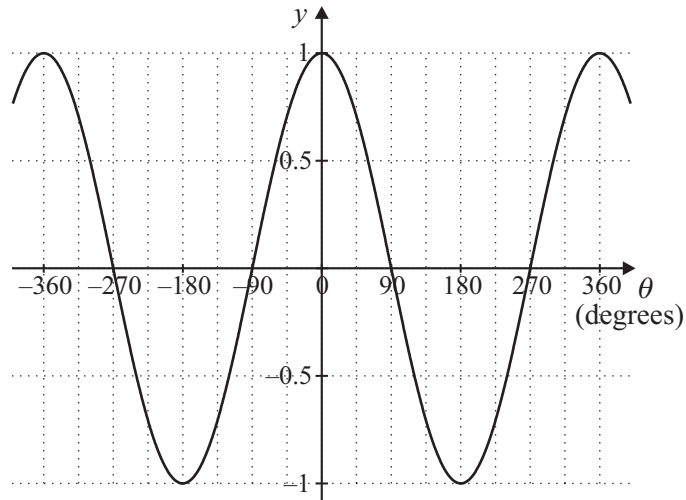

(b) The graph of $y = \cos \theta$ has the same period and amplitude as the graph $y = \sin \theta$ but the graph of $y = \cos \theta$ is displaced or shifted 90° to the left, so it appears to lead the sine curve.

Activity 8.171. (a) $\theta \approx 64^\circ, 296^\circ, -64^\circ \dots$ (b) $\theta \approx 88^\circ, 272^\circ, -88^\circ \dots$ (c) $\theta \approx 150^\circ, 210^\circ, -150^\circ \dots$ (d) $\theta \approx 115^\circ, 245^\circ, -115^\circ \dots$

2. Solutions as above.

3. (a) $\cos^{-1} 0.24 = \theta$

$$\theta = 103.89^\circ$$

θ is negative in the second and third quadrant. (In the second quadrant $103.89^\circ = 180 - 76.11^\circ$.) So the other angle must be in the third quadrant.

$$180^\circ + 76.11^\circ = 256.11^\circ$$

(b) $\cos^{-1} 0.83 = \theta$

$$\theta = 33.90^\circ$$

θ is positive in the first and fourth quadrant. The other angle must be $360^\circ - 33.90^\circ = 326.10^\circ$.

4. (a)

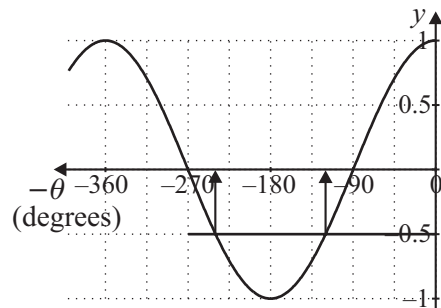

-0.5 (from 0° to -360°)

$$\theta = \cos^{-1}(-0.5)$$

$$\theta = 120^\circ$$

Since the domain is between 0° and -360° , and \cos is negative in the second and third quadrants, the angles must be -120° and -240° .

(b)

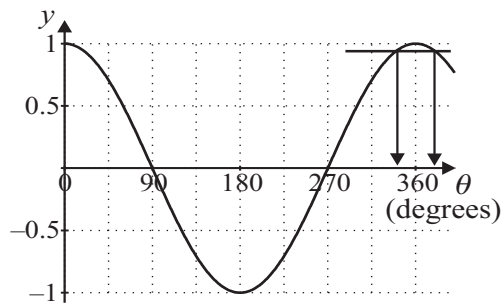

0.9397 (from 200° to 400°)

$$\theta = \cos^{-1} 0.9397$$

$$\theta = 20^\circ$$

Since the domain is between 200° and 400° , and \cos is positive in the first and fourth quadrants, the angles must be 340° and 380° .

(c)

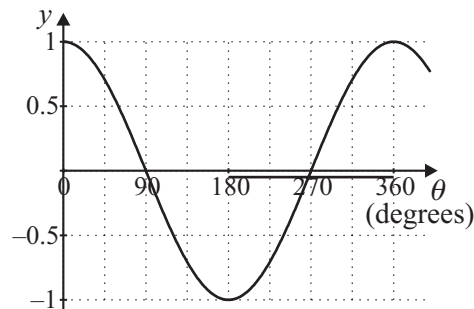

-0.0523 (from 180° to 360°)

$$\theta = \cos^{-1}(-0.0523)$$

$$\theta = 93^\circ$$

Since the domain is between 180° and 360° , and \cos is negative in the second and third quadrants, the only angle is 267° .

(d)

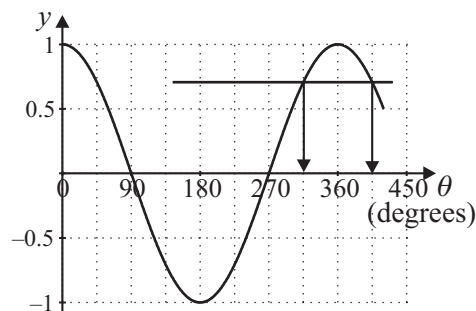

0.7071 (from 90° to 450°)

$$\theta = \cos^{-1}(0.7071)$$

$$\theta = 45^\circ$$

Since the domain is between 90° and 450° , and \cos is positive in the first and fourth quadrants, the angles are 315° and 405° .

Activity 8.18

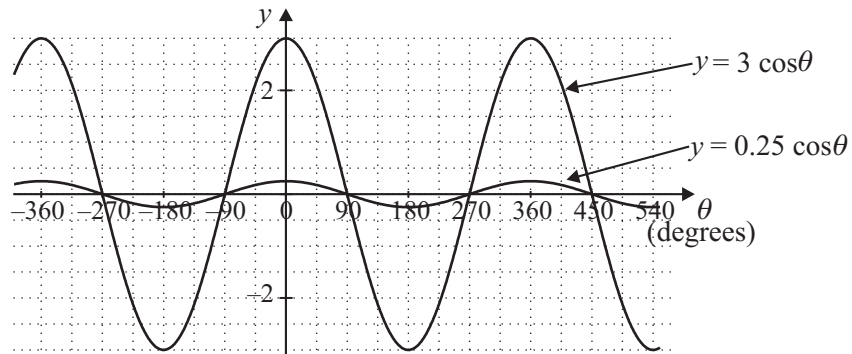

Activity 8.19

- (a) period = 72°
- (b) period = 240°
- (c) period = 180°

Activity 8.20

1.

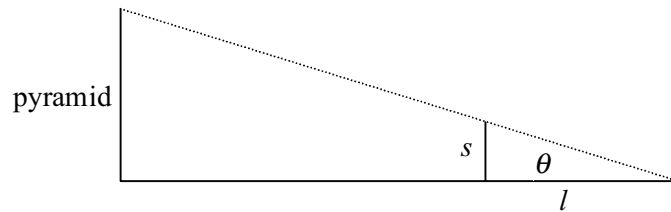

s = stick length
 l = length of stick's shadow

Find the length of the staff and the length of the shadow. The ratio of these $\frac{s}{l}$ (the tan of the angle θ) is equal to the ratio of the height of the pyramid over the shadow of the pyramid.

Activity 8.21

1.

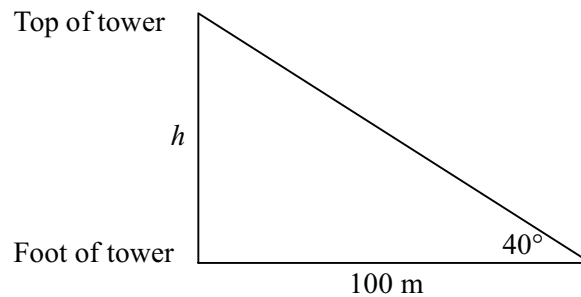
Let h be the height of the tower

$$\tan 40^\circ = \frac{\text{op}}{\text{adj}}$$

$$\tan 40^\circ = \frac{h}{100}$$

$$100 \tan 40^\circ = h$$

$$h \approx 83.910$$

Therefore the height of the tower is approximately 83.910 m.

2.

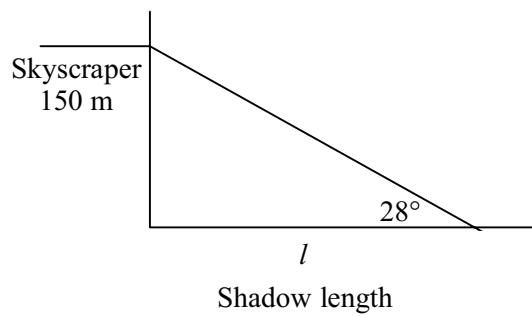
Let l be the length of the shadow in metres

$$\tan 28^\circ = \frac{\text{opp}}{\text{adj}}$$

$$\tan 28^\circ = \frac{150}{l}$$

$$l \tan 28^\circ = 150$$

$$l = \frac{150}{\tan 28^\circ}$$

$$l \approx 282.109$$

Therefore the shadow length is approximately 282 m.

3.

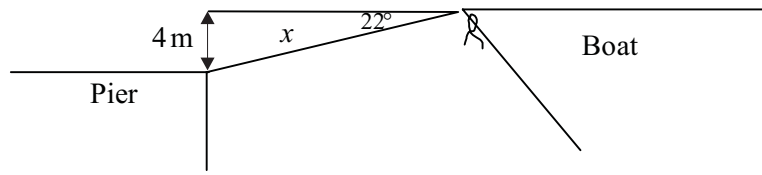

Let x be the distance of the boat from the pier in metres

$$\tan 22^\circ = \frac{\text{opp}}{\text{adj}}$$

$$\tan 22^\circ = \frac{4}{x}$$

$$x \tan 22^\circ = 4$$

$$x = \frac{4}{\tan 22^\circ}$$

$$x \approx 9.9003$$

Therefore the boat is approximately 9.9 m from the pier.

4.

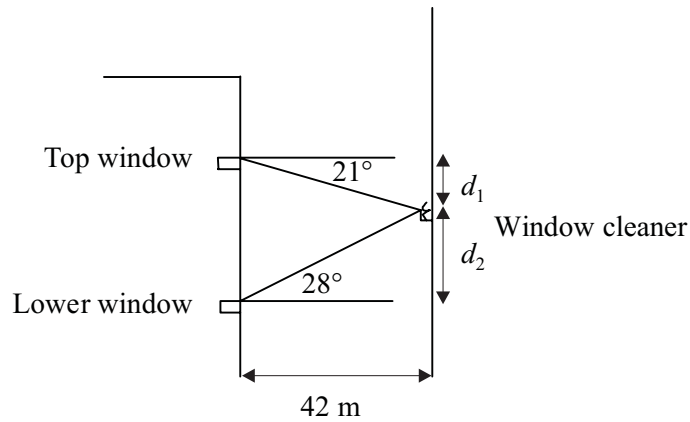

Let d_1 be the distance from the top window to the window cleaner.

Let d_2 be the distance from the lower window to the window cleaner.

First consider the distance from the top window,

$$\tan 21^\circ = \frac{\text{opp}}{\text{adj}}$$

$$\tan 21^\circ = \frac{d_1}{42}$$

$$42 \tan 21^\circ = d_1$$

$$d_1 \approx 16.122$$

Therefore the distance to the top window is approximately 16.122m.

Consider the distance from the lower window,

$$\begin{aligned}\tan 28^\circ &= \frac{\text{opp}}{\text{adj}} \\ \tan 28^\circ &= \frac{d_2}{42} \\ 42 \tan 28^\circ &= d_2 \\ d_2 &\approx 22.332\end{aligned}$$

Therefore the distance from the bottom window is approximately 22.332m.

Therefore the total distance between the two windows is $16.122 \text{ m} + 22.332 \text{ m} = 38.454 \text{ m}$.

Activity 8.22

Find the value of $\frac{y}{x}$ in the following diagrams.

(a) $\tan 65^\circ = \frac{y}{x}$

$$\frac{y}{x} \approx 2.1445$$

(b) $\tan 14^\circ = \frac{y}{x}$

$$\frac{y}{x} \approx 0.2493$$

(c) $\tan 40^\circ = \frac{y}{x}$

$$\frac{y}{x} \approx 0.8391$$

Activity 8.23

1. (a)

θ	$\tan \theta$	$\sin \theta$	$\cos \theta$
0°	0	0	1
90°	undefined	1	0
180°	0	0	-1
270°	undefined	-1	0
360°	0	0	1

(b)

Positive: sin	Positive: sin, cos, tan
Positive: tan	Positive: cos

One way to think of this is the diagram which indicates the ratios that are positive:

S	A
T	C

Now think of a way to remember these 4 letters – something like *All Students Take Chemistry* or *All Stations To Central*.

2.

α	Quadrant	Sign (\pm)	$\tan \alpha$
125	2nd	–	–1.4281
160	2nd	–	–0.3640
189	3rd	+	0.1584
235	3rd	+	1.4281
280	4th	–	–5.6713
320	4th	–	–0.8391
350	4th	–	–0.1763
390	1st	+	0.5774
520	2nd	–	–0.3640
600	3rd	+	1.7321
650	4th	–	–2.7475
–250	2nd	–	–2.7475
–200	2nd	–	–0.3640
–100	3rd	+	5.6713

Activity 8.24

1. (a)

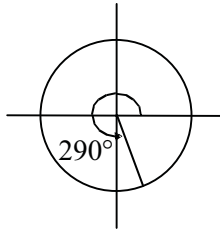

(b) $360^\circ - 290^\circ = 70^\circ$
 $\alpha = 70^\circ$

(c) $\tan 290^\circ$ is negative, so tangents in quadrant 2 are negative

(d) $\beta = 70^\circ$

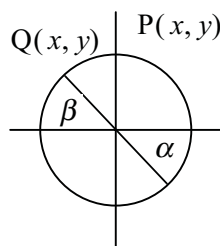

(e) The coordinates of Q will be,

$$x = -\cos 70^\circ = -0.3420$$

$$y = \sin 70^\circ = 0.9397$$

The angle with the same tangent as 290° will be $180^\circ - 70^\circ = 110^\circ$.

2. (a)

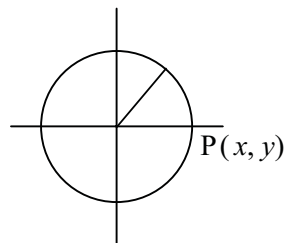

(b) $\tan 50^\circ$ is positive, so tangents in quadrant 3 are positive.

(c)

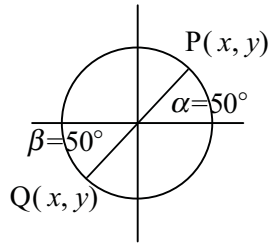

(d) The coordinates of Q will be,

$$x = -\cos 50^\circ = -0.6428$$

$$y = -\sin 50^\circ = -0.7660$$

The angle with the same tangent as 50° will be $180^\circ + 50^\circ = 230^\circ$.

Activity 8.25

(Your answer would be bigger than this graph.)

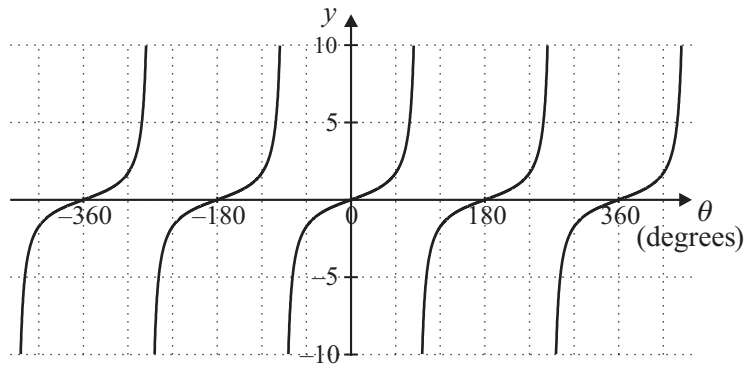

Activity 8.26

1. (You may not have these exact answers)

- (a) $\theta \approx 22^\circ, 202^\circ, -158^\circ, \dots$
- (b) $\theta \approx 63^\circ, 243^\circ, -117^\circ, \dots$
- (c) $\theta \approx 82^\circ, 262^\circ, -98^\circ, \dots$
- (d) $\theta \approx 141^\circ, 321^\circ, -39^\circ, \dots$
- (e) $\theta \approx 158^\circ, 338^\circ, -22^\circ, \dots$
- (f) $\theta \approx 119^\circ, 299^\circ, -61^\circ, \dots$

2. Find the angles in the specified domain that have the following tangents. (You may like to use the unit circle to help decide all angles involved.)

(a)

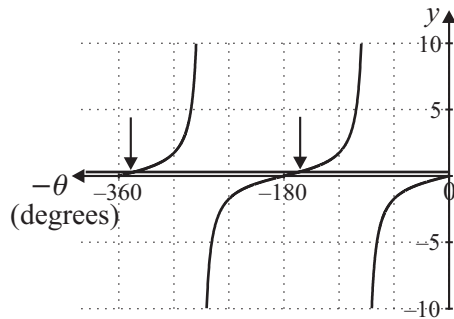

0.3057 (from 0° to -360°)

$$\theta = \tan^{-1} 0.3057$$

$$\theta = 17^\circ$$

Since the domain is between 0° and -360° , and \tan is positive in the first and third quadrants, then the angles must be -163° and -343° .

(b)

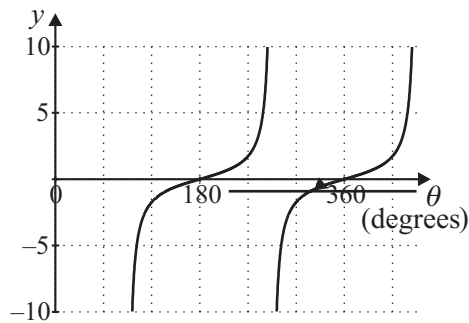

-0.9004 (from 180° to 450°)

$$\theta = \tan^{-1} (-0.9004)$$

$$\theta = -42^\circ$$

Since the domain is between 180° and 450° , and \tan is negative in the second and fourth quadrants, then the only angle is 318° .

(c)

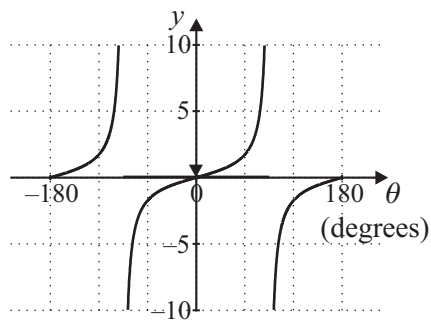

0.0524 (from -90° to 90°)

$$\theta = \tan^{-1} 0.0524$$

$$\theta = 3^\circ$$

Since the domain is between -90° and 90° , and \tan is positive in the first and third quadrants, then the angles must be 3° and -3° .

(d)

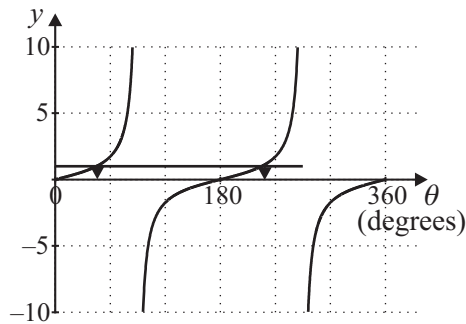

1 (from 0° to 360°)

$$\theta = \tan^{-1} 1$$

$$\theta = 45^\circ$$

Since the domain is between 0° and 360° , and \tan is positive in the first and third quadrants, then the angles must be 45° and 225° .

(e)

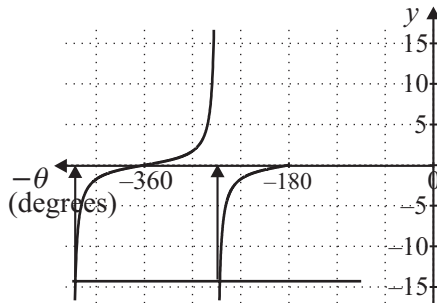

-14.30 (from -180° to -450°)

$$\theta = \tan^{-1} (-14.30)$$

$$\theta = -86^\circ$$

Since the domain is between -180° and -450° and the domain is negative in the second and fourth quadrants, then the angles must be -266° and -446° .

Activity 8.27

(a)

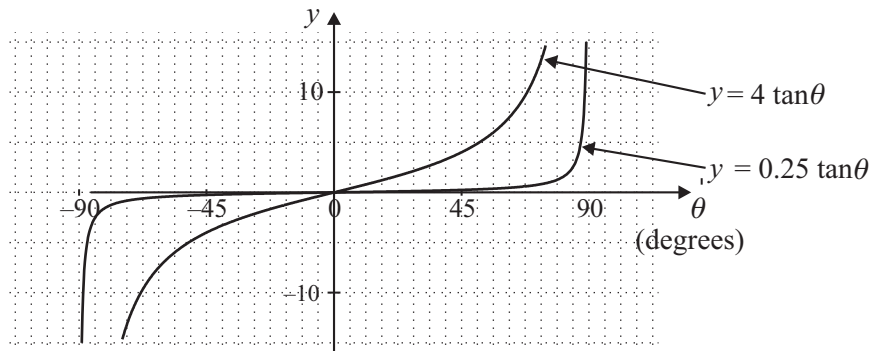

(b) While the basic shapes of the two graphs are the same, (a) graph increases 16 times as quickly as graph (b) in the first quadrant, and is decreasing 16 times as quickly in the third quadrant.

Activity 8.28

(a) Period = 90°

(b) Period = 900°

(c) Period = 90°

Activity 8.29

$$1. \quad \tan \beta = \frac{\sin \beta}{\cos \beta}$$

$$\tan \beta = \frac{5}{13} \div \frac{12}{13}$$

$$\tan \beta = \frac{5}{13} \times \frac{13}{12}$$

$$\tan \beta = \frac{5}{12}$$

$$2. \quad \tan \alpha = \frac{\sin \alpha}{\cos \alpha}$$

$$\tan \alpha = \frac{1}{2} \div \frac{\sqrt{3}}{2}$$

$$\tan \alpha = \frac{1}{2} \times \frac{2}{\sqrt{3}}$$

$$\tan \alpha = \frac{1}{\sqrt{3}}$$

$$3. \quad \tan \theta = \frac{\sin \theta}{\cos \theta}$$

$$\sin \theta = \cos \theta \times \tan \theta$$

$$\sin \theta = 0.9272 \times 0.4040$$

$$\sin \theta \approx 0.3746$$

Activity 8.30

$$1. \quad \sin^2 \theta + \cos^2 \theta = 1$$

$$(-0.5)^2 + \cos^2 \theta = 1$$

$$0.25 + \cos^2 \theta = 1$$

$$\cos^2 \theta = 0.75$$

$$\cos \theta = \pm \sqrt{0.75}$$

$$\cos \theta \approx \pm 0.8660$$

$$2. \quad \sin^2 \alpha + \cos^2 \alpha = 1$$

$$\sin^2 \alpha + (0.7071)^2 = 1$$

$$\sin^2 \alpha + 0.49999041 = 1$$

$$\sin^2 \alpha \approx 0.5$$

$$\sin \alpha \approx \pm \sqrt{0.5}$$

$$\sin \alpha \approx \pm 0.7071$$

$$\begin{aligned}
3. \quad \sin^2 x + \cos^2 x &= 1 \\
(0.6428)^2 + \cos^2 x &= 1 \\
0.41319184 + \cos^2 x &= 1 \\
\cos^2 x &= 0.58680816 \\
\cos x &= \pm\sqrt{0.58680816} \\
\cos x &= \pm 0.7660
\end{aligned}$$

Using this result to find $\tan x$

$$\begin{aligned}
\tan x &= \frac{\sin x}{\cos x} \\
\tan x &= \frac{0.6428}{0.7660} \\
\tan x &= 0.8392
\end{aligned}$$

Also, when $\cos x = -0.7660$ then $\tan x = -0.8392$.

Therefore, when $\sin x = 0.6428$, $\cos x = \pm 0.7660$ and $\tan x = \pm 0.8392$.

Activity 8.31

$$(a) (\sin 20^\circ)^{-1} = \frac{1}{\sin 20^\circ} \approx \frac{1}{0.3420} \approx 2.9240$$

$$(b) \cos 1.4^{-1} = \cos \frac{1}{1.4} \approx \cos 0.7143 \approx 0.9999$$

$$(c) \tan^2 120^\circ = \tan 120^\circ \times \tan 120^\circ \approx -1.7321 \times -1.7321 \approx 3.0002$$

$$(d) \sin 1.2^2 = \sin 1.44 \approx 0.0251$$

$$(e) (\cos 31.4^\circ)^{-1} = \frac{1}{\cos 31.4^\circ} \approx -1.1716$$

Solutions to a taste of things to come

1. (a)

$$(i) R = \frac{v_0^2 \sin 2\theta}{g}$$

Rearranging,

$$\sin 2\theta = \frac{Rg}{v_0^2}$$

$$\sin 2\theta = \frac{160 \times 9.81}{60^2}$$

$$\sin 2\theta = 0.436$$

$$2\theta = 25.85^\circ$$

$$\theta = 12.92^\circ$$

Therefore the angle of the cannon should be 12.92° .

(ii) target Z which is 220 m away.

$$R = \frac{v_0^2 \sin 2\theta}{g}$$

Rearranging,

$$\sin 2\theta = \frac{Rg}{v_0^2}$$

$$\sin 2\theta = \frac{220 \times 9.81}{60^2}$$

$$\sin 2\theta = 0.5995$$

$$2\theta = 36.83^\circ$$

$$\theta = 18.42^\circ$$

Therefore the angle of the cannon should be 18.42° .

- (b)
(i) target X was 400 m away from the cannons

$$R = \frac{v_0^2 \sin 2\theta}{g}$$

$$\sin 2\theta = \frac{Rg}{v_0^2}$$

$$\sin 2\theta = \frac{400 \times 9.81}{60^2}$$

$$\sin 2\theta = 1.09$$

This is not possible as sin cannot be greater than 1. This means that the cannon could not reach the target under the conditions described.

- (ii) target X was 360 m away from the cannons

$$R = \frac{v_0^2 \sin 2\theta}{g}$$

$$\sin 2\theta = \frac{Rg}{v_0^2}$$

$$\sin 2\theta = \frac{360 \times 9.81}{60^2}$$

$$\sin 2\theta = 0.981$$

$$2\theta = 78.81^\circ$$

$$\theta = 39.41^\circ$$

Therefore aiming the cannon at an angle of 39.41° would enable the cannons on the eastern wall to hit target X.

- (c)
(i) What angle would he set the cannon to strike target X 190 m away.

$$\sin 2\theta = \frac{Rg}{v_0^2}$$

$$\sin 2\theta = \frac{190 \times 9.81}{60^2}$$

$$\sin 2\theta = 0.51775$$

$$2\theta = 31.18^\circ$$

$$\theta = 15.59^\circ$$

Therefore the cannon should be set to 15.59° .

(ii) If he overshoot the target by 25 m, what was the actual muzzle velocity.

$$R = \frac{v_0^2 \sin 2\theta}{g}$$

Rearranging,

$$\begin{aligned} v_0^2 &= \frac{Rg}{\sin 2\theta} \\ v_0^2 &= \frac{215 \times 9.81}{\sin(2 \times 15.59)} \\ v_0^2 &\approx 4073.854 \\ v_0 &\approx \pm \sqrt{4073.854} \\ v_0 &\approx 63.83 \end{aligned}$$

Therefore the muzzle velocity must have been approximately 64 m/s.

2. (a) $n_1 \sin \theta_1 = n_2 \sin \theta_2$

$$\sin \theta_2 = \frac{n_1 \sin \theta_1}{n_2}$$

$$\sin \theta_2 = \frac{1.00 \sin 63^\circ}{1.33}$$

$$\sin \theta_2 \approx 0.6699$$

$$\theta_2 \approx 42.06^\circ$$

Therefore the angle of refraction is 42.06° .

(b) $n_1 \sin \theta_1 = n_2 \sin \theta_2$

$$\sin \theta_2 = \frac{n_1 \sin \theta_1}{n_2}$$

$$\sin \theta_2 = \frac{1.33 \sin 23^\circ}{1.00}$$

$$\sin \theta_2 \approx 0.5197$$

$$\theta_2 \approx 31.31^\circ$$

Therefore the angle of refraction is 31.31° .

$$\begin{aligned}
 \text{(c)} \quad n_1 \sin \theta_1 &= n_2 \sin \theta_2 \\
 \sin \theta_1 &= \frac{n_2 \sin \theta_2}{n} \\
 \sin \theta_1 &= \frac{1.33 \sin 35^\circ}{1.00} \\
 \sin \theta_1 &\approx 0.7629 \\
 \theta_1 &\approx 49.72^\circ
 \end{aligned}$$

Therefore the incident angle of the rays from the sun is 49.72° , which means the sun is 40.28° above the horizon.

3. (a)

$$\text{(i)} \quad 1.50 \text{ m}$$

$$\text{(ii)} \quad 0.75 \text{ m}$$

$$\text{(iii)} \quad 0.50 \text{ m}$$

(b)

$$\text{(i)} \quad \mu = \text{mass per unit length} = \frac{0.003}{0.75} = 0.004 \text{ kg/m}$$

$$\begin{aligned}
 \text{(ii)} \quad v &= \sqrt{\frac{F_T}{\mu}} \\
 v &= \sqrt{\frac{680}{0.004}} \\
 v &= \sqrt{170000} \\
 v &\approx 412 \text{ m/s}
 \end{aligned}$$

(c)

$$\begin{aligned}
 \text{(i)} \quad f &= \frac{v}{\lambda} \\
 f &= \frac{412}{1.5} \\
 f &\approx 275 \text{ Hz}
 \end{aligned}$$

Therefore the frequency of vibration of the first harmonic is 275 Hz.

$$\begin{aligned} \text{(ii)} \quad f &= \frac{v}{\lambda} \\ f &= \frac{412}{0.75} \\ f &= 550\text{Hz} \end{aligned}$$

Therefore the frequency of vibration of the second harmonic is 550Hz.

$$\begin{aligned} f &= \frac{v}{\lambda} \\ f &= \frac{412}{0.5} \\ f &= 824\text{Hz} \end{aligned}$$

Therefore the frequency of vibration of the third harmonic is 824 Hz.

(iii) Increasing the tension would increase the velocity of the sound as shown in the formula, $v = \sqrt{\frac{F_T}{\mu}}$, this would increase the frequency of the sound as evident from the formula, $f = \frac{v}{\lambda}$, therefore, the pitch of the sound would be increased.

Solutions to post-test

$$1. \text{ (a) } \sin 33^\circ = \frac{\text{op}}{\text{hyp}}$$

$$\sin 33^\circ = \frac{20}{x}$$

$$x \times \sin 33^\circ = 20$$

$$x = \frac{20}{\sin 33^\circ}$$

$$x \approx 36.72$$

$$\text{(b) } \cos 6^\circ = \frac{\text{adj}}{\text{hyp}}$$

$$\cos 6^\circ = \frac{x}{15}$$

$$15 \cos 6^\circ = x$$

$$x \approx 14.92$$

$$\text{(c) } \tan 53^\circ = \frac{\text{opp}}{\text{adj}}$$

$$\tan 53^\circ = \frac{x}{27}$$

$$27 \tan 53^\circ = x$$

$$x \approx 35.83$$

$$2. \text{ (a) } 0$$

$$\text{(b) undefined}$$

$$\text{(c) } -1$$

$$3. \text{ (a) } \sin \theta = 0.4695$$

$$\theta = \sin^{-1} 0.4695$$

$$\theta = 28.0^\circ$$

Since the domain is between 0° and 360° , and sin is positive in the first and second quadrants, then the angles must be 28.0° and 152.0° .

$$\text{(b) } \cos \theta = -0.752$$

$$\theta = \cos^{-1}(-0.752)$$

$$\theta = 138.8^\circ$$

Since the domain is between 0° and 360° , and cos is negative in the second and third quadrants, then the angles must be 138.8° and 221.2° .

$$\begin{aligned} \text{(c) } \tan \theta &= 2 \\ \theta &= \tan^{-1} 2 \\ \theta &= 63.4^\circ \end{aligned}$$

Since the domain is between 0° and 360° , and \tan is positive in the first and third quadrants, then the angles must be 63.4° and 243.4° .

4. (a) $438^\circ, 798^\circ, \dots$

(b) $605^\circ, 965^\circ, \dots$

5. 19.254

Converting decimal to minutes, $0.254 \times 60 = 15.24$ minutes.
Converting decimal to seconds, $0.24 \times 60 = 14.4$ seconds.

Therefore, answer = $19^\circ 15' 14.4''$.

6. $124^\circ 16' 54''$

$$16'54'' = \frac{16 \times 60 + 54}{60 \times 60} \approx 0.282$$

Therefore, answer = 124.282° .

7. amplitude = 0.5 period = 1080°

8. From the Pythagorean identity

$$\begin{aligned} \sin^2 x + \cos^2 x &= 1 \\ \sin^2 x + 0.6381^2 &= 1 \\ \sin^2 x &\approx 0.59282839 \\ \sin x &\approx \pm 0.7700 \end{aligned}$$

If the \cos of an angle is positive, then the \sin of that angle can be positive or negative.

Therefore, $\sin x = 0.7700$ or -0.7700 .

From the quotient identity,

$$\begin{aligned} \tan x &= \frac{\sin x}{\cos x} \\ \tan x &\approx \frac{0.7700}{0.6381} \\ \tan x &\approx 1.2066 \end{aligned}$$

Considering the negative value of \sin also, then $\tan x = 1.2066$ or -1.2066 .

9. (a) $\cos 1.4 = 0.9997$

(b) $(\sin 45^\circ)^{-1} = \frac{1}{\sin 45^\circ} = 1.4142$

(c) $(\tan 26^\circ)^2 \times = \tan 26 \times \tan 26 \approx 0.2379$

10.

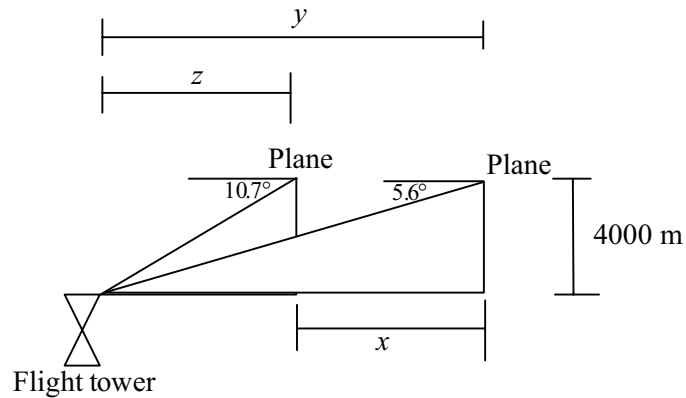

Let x be the distance travelled in 20 minutes.

Let y be the distance of the plane from the first observation point.

Let z be the distance of the plane from the second observation point.

As $\text{speed} = \frac{\text{distance}}{\text{time}}$, it is necessary to calculate the distance x travelled in 20 minutes.

Calculating distance y ,

$$\tan 5.6^\circ = \frac{\text{op}}{\text{adj}}$$

$$\tan 5.6^\circ = \frac{4000}{y}$$

$$y = \frac{4000}{\tan 5.6^\circ}$$

$$y = 40795.15$$

Calculating distance x ,

$$\tan 10.7^\circ = \frac{\text{op}}{\text{adj}}$$

$$\tan 10.7^\circ = \frac{4000}{x}$$

$$x = \frac{4000}{\tan 10.7^\circ}$$

$$x = 21169.40$$

Therefore distance x is,

$$x = 40795.15 - 21169.40 = 19625.75$$

Therefore the distance travelled in 20 minutes is 19625.75 m.

Therefore the speed in km/h is,

$$\begin{aligned} \text{speed} &= \frac{\text{distance}}{\text{time}} \\ \text{speed} &= \frac{19.62575}{\frac{1}{3}} \text{ km/h} \\ \text{speed} &= 58.88 \text{ km/h} \end{aligned}$$

Therefore the speed of the plane is 58.88 km/h.

11.

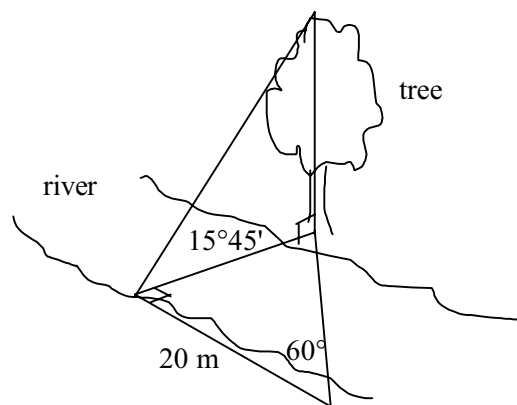

Let x be the distance across the river in metres.

Let y be the height of the tree in metres.

Calculating the distance across the river,

$$\tan 60^\circ = \frac{\text{op}}{\text{adj}}$$

$$\tan 60^\circ = \frac{x}{20}$$

$$20 \tan 60^\circ = x$$

$$x \approx 34.64$$

Therefore the width of the river is 34.64 m.

Calculating the height of the tree,

$$\tan 15.45^\circ = \frac{\text{op}}{\text{adj}}$$

$$\tan 15.45^\circ = \frac{y}{34.64}$$

$$34.64 \tan 15.45^\circ = y$$

$$y \approx 9.57$$

Therefore the height of the tree is 9.57 m.