

Module C4

Trigonometrical functions

Introduction

Think about waves crashing on a beach, the beat of your heart, watching television, jumping on a trampoline and bank interest rates. All of these things have one thing in common: they can be represented by trigonometric functions. This is because they repeat their values at regular intervals. In fact, Jean Baptiste Fourier (1768–1830) showed that almost any function over a given domain can be represented by a series made up of trigonometric functions. For example, believe it or not, the fat stored (y) in a lizard's tail in months (m) is represented by the function:

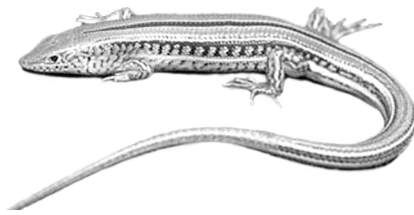

$$y = 0.257 - 0.09 \cos \frac{2\pi m}{12} + 0.064 \sin \frac{2\pi m}{12} - 0.049 \cos 2 \frac{2\pi m}{12}$$

Sine and cosine functions are essential to the study of ALL periodic phenomena. They are important in optics and acoustics, information theory and quantum mechanics. So knowing how to manipulate equations, and recognize and draw graphs from these functions will become important.

The main focus of this module will be to build on your knowledge of trigonometric functions (sometimes called periodic functions). In TPP7182 or equivalent mathematics courses you will have examined sine, cosine and tangent ratios in triangles and looked closely at functions such as $y = \sin \theta$. You may need to do some revision on this topic before you start. Could you do the revision topics on trigonometry? If not, contact your tutor to discuss what you need to do and how we can help. More formally, when you have successfully completed this module you should be able to:

- demonstrate an understanding of the concept of radian measurement
- convert from degrees to radians and vice versa
- use radian measure in various applications
- define and calculate trigonometric ratios for any angle
- describe and sketch trigonometric functions of sine, cosine and tangent
- calculate the amplitude, vertical shift, period and phase of a function from its equation and graph
- understand the nature of inverse trigonometric functions
- solve trigonometric equations using trigonometric identities.

4.1 Radian measure

One of the features of trigonometric relationships is the way we treat the independent variable. Up to now we have used Greek letters such as θ to identify the independent variable. As we study more trigonometry, in many cases we no longer treat θ as an angle (i.e. a measure of the amount of turning), but as a real number. When we deal with it as a real number, we usually don't use the number of degrees as a measure of the angle, but another measure. This is called radian measure. We will look at this first before studying trigonometric functions in more detail.

Let's look at the sine wave the way Fourier saw it back in 1801. He saw sound waves as imitating the sine curve. The function he saw was not the relationship between the angle and the length of the sides of a triangle, but the relationship between the time the sound had been emitted and sound intensity. For electricity it's the relationship between the time and the magnitude of current flowing. In these examples we usually talk in terms of time periods or lengths not in actual amount of turning of an angle (although the analogy is often used in electricity since alternating current goes in cycles). In this and many other applications involving trigonometry we define the independent variable as a real number.

4.1.1 What are radians?

One way to think of radians is to think of the length of an arc that is created from the turning involved in making an angle in a circle (we say the arc is subtended by the angle).

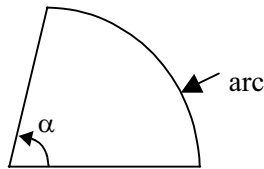

Consider an angle of 90° . It results from one quarter of a turn around a circle. Recall that the circumference of a circle is $2\pi r$, so one quarter of this will be $\frac{2\pi r}{4}$ or $\frac{\pi r}{2}$.

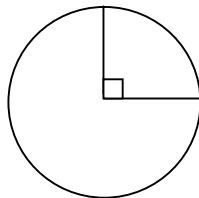

If a circle has a radius of 1 metre, then the length of the arc created by a 90° turn is $\frac{\pi}{2}$ metres or about 1.57 metres.

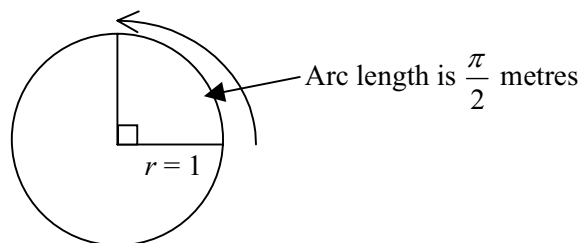

If the circle had a radius of 2 metres the length of the arc created by the 90° turn would be:

$$\frac{2\pi \times 2}{4} = \pi \text{ metres or about 3.14 metres.}$$

So the arc length in the 2 metre circle is twice the length of the previous unit circle's arc.

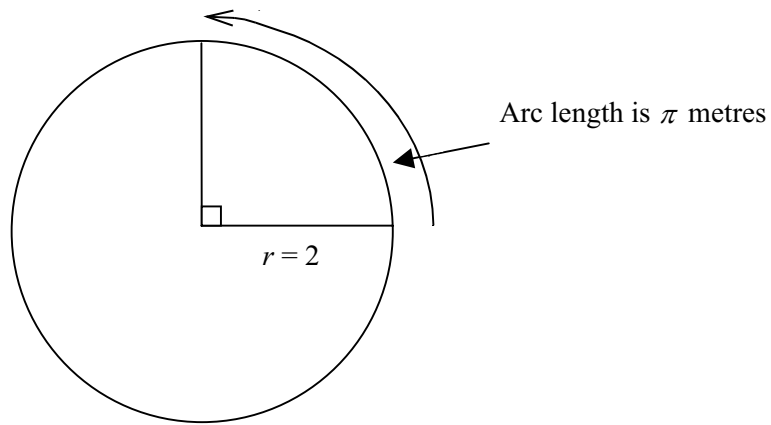

However, when we deal in radians, we are not interested in the arc length but the ratio of the arc length to the length of the radius. In the diagram below, for each radius, let's calculate the arc length and the associated ratio of arc length to radius.

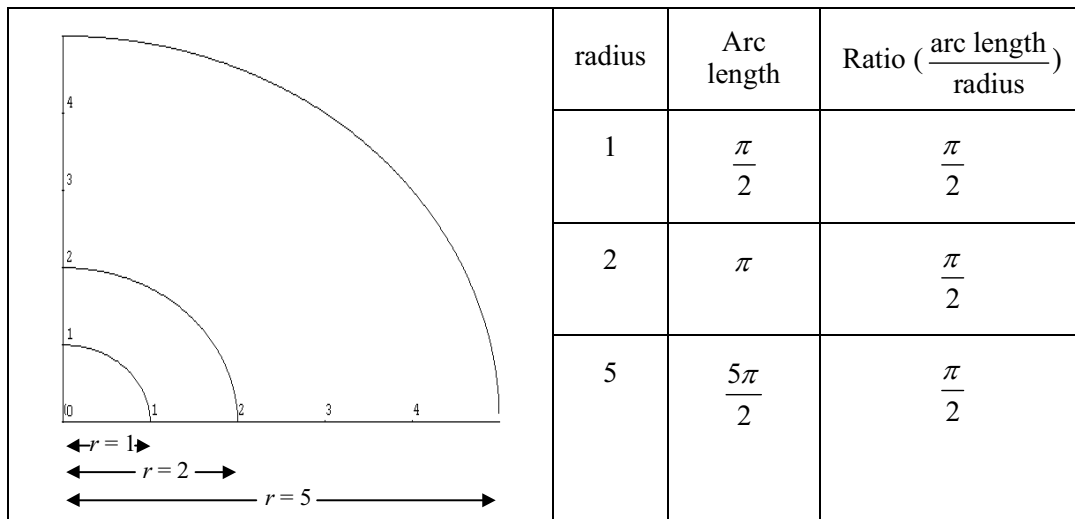

In each case the ratio of the arc length to the radius is the same. This will be true no matter what the radius is. If we look at 90° in a circle with a radius r then the ratio of the arc length to the radius will be:

$$\begin{aligned} \frac{2\pi r}{4} \div r &= \frac{2\pi \times r}{4} \times \frac{1}{r} \\ &= \frac{2\pi}{4} \\ &= \frac{\pi}{2} \end{aligned}$$

So we say an angle of 90° is the same as $\frac{\pi}{2}$ radians. $\frac{\pi}{2}$ is approximately 1.57 radians, but as this is only approximate, we often leave the notation in terms of π .

Let's look at other angles.

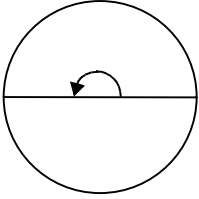
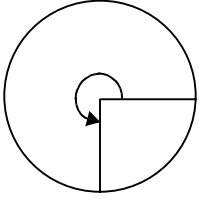
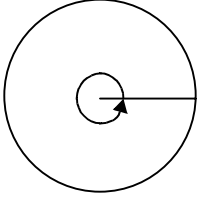
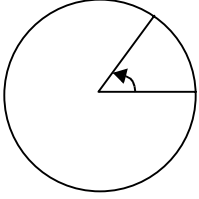
Angle (in degrees)	Fraction of the circle	Length of arc	Ratio of arc to radius	Angle (in radians)
180° 	Half the circle	$\frac{1}{2} \times 2\pi r$ $= \pi r$	$\frac{\pi r}{r}$	π radians
270° 	Three quarters of the circle	$\frac{3}{4} \times 2\pi r$ $= \frac{3\pi r}{2}$	$\frac{3\pi r}{2r}$	$\frac{3\pi}{2}$ radians
360° 	The full circle	$2\pi r$	$\frac{2\pi r}{r}$	2π radians
60° 	One sixth of the circle	$\frac{1}{6} \times 2\pi r$ $= \frac{\pi r}{3}$	$\frac{\pi r}{3r}$	$\frac{\pi}{3}$ radians

The angles above commonly occur in trigonometry. However, you should be able to convert any angle to its radian equivalent.

4.1.2 Converting from degrees to radians

In many branches of mathematics you will need to work in radians, so it is important that you can convert from degrees to radians. To convert to radians, find the angle as a fraction of the full circle (360°) then multiply by 2π .

Example

Find 47° in radian measure.

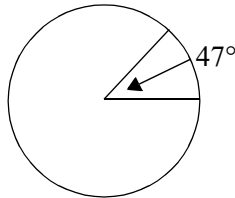

47° is $\frac{47}{360}$ of the full circle

$$47^\circ = \frac{47}{360} \times \frac{2\pi}{1}$$

$$\approx 0.820 \text{ radians}$$

Activity 4.1

1. Find the following angles in terms of radians:

- (a) 35° (b) 98° (c) 350° (d) 120° (e) 300°

4.1.3 Converting from radians to degrees

To convert from radians to degrees, find the angle as a fraction of the full circle (2π) then multiply by 360° .

Example

Find $\gamma = 4.27$ radians in terms of degrees (γ is the Greek letter 'gamma').

(i) $y = 4.27$ radians

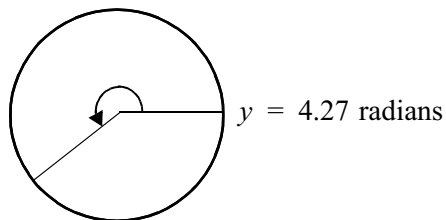

$$4.27 \text{ radians} = \frac{4.27}{2\pi} \times \frac{360}{1}$$

$$\approx 244.65^\circ$$

Example

- (ii) Find $\gamma = \frac{7}{8}\pi$ radians in terms of degrees (γ is the Greek letter ‘gamma’).

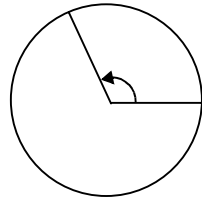

$$\gamma = \frac{7}{8}\pi \text{ radians}$$

Of course you could simplify this by thinking π radians is 180° .

$$\text{So } \frac{7\pi}{8} \text{ radians} = \frac{7\pi}{8} \times \frac{180}{\pi} \text{ degrees.}$$

$$\begin{aligned} \frac{7\pi}{8} \text{ radians} &= \frac{7\pi}{2\pi} \times \frac{360}{1} \\ &= \frac{7\pi}{8} \times \frac{360}{2\pi} \\ &= 157.5^\circ \end{aligned}$$

Activity 4.2

1. Find the following angles in terms of degrees:

(a) $\gamma = 3.15$ radians (b) $\gamma = \frac{3}{4}\pi$ radians (c) $\gamma = \frac{5\pi}{6}$ radians

2. Complete the following table:

Degrees	Approximate value in radians	Exact value in radians using π)
30°	0.52 radians	$\frac{\pi}{6}$
45°		
60°		
90°		
180°		
270°		
360°		

The first and third columns in the table above are useful to remember since you will often use these key angles to plot points when drawing trigonometric functions.

Some calculators (such as recent Sharp scientific calculators) have a conversion key (DRG ►) which will allow you to convert from radians to degrees or vice versa. See if you can use this key on your calculator. If you are having difficulty, contact your tutor.

To summarize so far:

When you measure an angle in terms of radians, you are really looking at the **ratio** of the arc length to the radius. This is a **real number**. We call the radian measure dimensionless since it has no unit (i.e. it is not a length – it is a length divided by a length).

Remember what a real number is? It's any number that can be represented on the number line. -7 , 0 , 345 are real numbers; all fractions are real numbers; all irrational numbers (e.g. $\sqrt{7}$) are real numbers, as are the numbers π and e .

Radian measure makes more sense in circumstances such as wave lengths, it simplifies many formulas and is crucial in other areas of mathematics such as calculus. Degrees are still commonplace, since most people are able to conceptualise a degree, but often a conversion to radians is necessary in formulas used in higher mathematics.

Remember: Radian measure is the measurement of an angle in terms of an arc length of a circle and its radius, i.e.:

$$\frac{\text{arc length}}{\text{radius}} = x \text{ radians,}$$

Sometimes you will see an alternative definition:

One radian is the angle measured at the centre of a circle that subtends an arc length of one radius along the circumference.

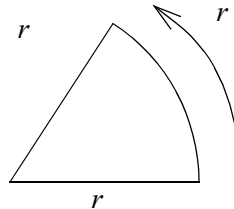
**Remember:**

$$1^\circ = \frac{2\pi}{360} \text{ radians or } 1 \text{ radian} = \frac{360^\circ}{2\pi} \text{ or simply}$$

$$360^\circ = 2\pi \text{ radians}$$

You might like to remember these rules (or make up one of your own):

$$\text{Degrees} \rightarrow \text{Radians: Degree} \times \frac{2\pi}{360}$$

$$\text{Radians} \rightarrow \text{Degrees: Radians} \times \frac{360}{2\pi}$$

Note: $360^\circ = 2\pi$ radians.
This does not mean $360 = 2\pi$.
 $2\pi \approx 6.283 \neq 360$. 2π radians
and 360° measure the same
angle in different units.

Note: If the degree sign is not shown it usually means the angle is measured in radians.

You can find the trigonometric ratios of angles expressed in radians on your calculator. Your calculator should have a **MODE** key or a **DRG** key. Use this to put your calculator into RADian mode. A RAD symbol should appear on your display. Check with your tutor if you have any problems.

Remember: If you are using angles expressed in degrees use **mode DEG**, in radians use **mode RAD**.

Example

Evaluate $\cos 2.7$

$$\cos 2.7 = -0.904 \text{ (the calculator is in radian mode)}$$

Example

Let y represent the fat stored in a lizard's tail in mg and m be the number of months. If $m = 5$ find y in the following equation.

$$\begin{aligned} y &= 0.257 - 0.09 \cos \frac{2\pi m}{12} + 0.064 \sin \frac{2\pi m}{12} - 0.049 \cos 2 \frac{2\pi m}{12} \\ y &= 0.257 - 0.09 \cos \frac{2\pi 5}{12} + 0.064 \sin \frac{2\pi 5}{12} - 0.049 \cos 2 \frac{2\pi 5}{12} \\ &\approx 0.257 - 0.09 \cos 0.833\pi + 0.064 \sin 0.833\pi - 0.049 \cos 1.667\pi \\ &\approx 0.257 + 0.0779 + 0.032 - 0.0245 \\ &\approx 0.3424 \end{aligned}$$

Approximately 0.34 mg of fat is stored in the fifth month.

Activity 4.3

1. Use your calculator to find the following values:

- (a) $\cos(2.75)$ (b) $\sin(0.023)$ (c) $\tan(1.7)$ (d) $\cos(27^\circ)$
 (e) $\sin\left(\frac{\pi}{2} - 0.7\right) \div \cos(0.7)$

2. It can be shown that:

$$\tan 4x = \frac{4 \tan x - 4 \tan^3 x}{1 - 6 \tan^2 x + \tan^4 x}$$

Show this is true for $x = \frac{\pi}{3}$

Remember: To calculate trig. ratios in degrees use **mode DEG**, in radians use **mode RAD**. This is one of the most common mistakes students make.

Note: The GRAD mode stands for GRADIANS or GRADE (short for centigrade). In gradian mode, a right angle stands for 100 gradians and fractional parts are reckoned decimally. Gradians are a decimal alternative to degrees but are only used in some European countries. This is an interesting example of a great idea (like changing from imperial to metric) that was never accepted by the international community. You are unlikely to come across grads in your studies.



Some students are confused by radians. How do you feel? You might like to add some comments in your learning diary on your experience with radians so far. If you find radians a bit daunting, you are not alone. We have many comments like:

“I find thinking in radians difficult. Can’t I just think in degrees?” (Janette)

“I still find I have a lot of need for improvement in dealing with plotting in terms of π radians from memory..” (George)

With more practice, radians will become more comfortable to use. Remember you can often think in degrees anyway and just transfer over to radians when you need to. Ask engineers – they will do this.

Something to talk about...

If you have access to the Internet, why not use a search engine and type in radians to see what comes up.

4.1.4 Using radian measure in real world applications

You will come across many applications using radians in science and engineering. Let’s have a look at some of these now.

Example

A toy elephant continually oscillates up and down at the end of a spring. The length of the spring L (in centimetres) after time t (in seconds) is given by the equation: $L = 12 + 2.5 \cos 2\pi t$. What is the length of the spring after 1.5 seconds? When will the spring be 12 cm long?

When $t = 1.5$,

$$\begin{aligned} L &= 12 + 2.5 \cos 2\pi 1.5 \\ &= 12 + 2.5 \cos 3\pi \\ &= 12 - 2.5 \\ &= 9.5 \end{aligned}$$

So the spring will be 9.5 cm long after 1.5 seconds.

When $L = 12$

$$L = 12 + 2.5 \cos 2\pi t$$

$$12 = 12 + 2.5 \cos 2\pi t$$

$$0 = \cos 2\pi t$$

$$0 = \cos 2\pi t$$

$$\cos^{-1} 0 = 2\pi t$$

$$1.5707963 \approx 2\pi t$$

$$\frac{1.5707963}{2\pi} \approx t$$

$$0.25 = t$$

$$t = 0.25$$

Recall, to find an angle given the cosine, press the inverse cos button on the calculator.

So the spring will be 12 cm long after a quarter of a second.

But of course it will come back to this point many more times. To find out when this occurs we must know the period of the function which we will investigate later in this module.

Example

Suppose you wanted to build a house with a curved roof. For the designer to draw your roof, she must assume the roof is an arc of a circle. The roof can't be too steep, so it works out that the best arc is one with a radius of 12 metres and subtended by an angle of 25° .

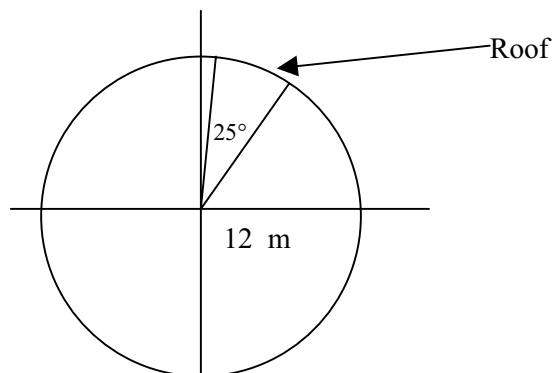
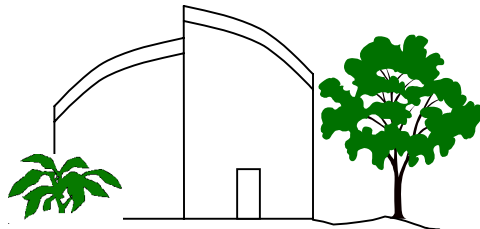

What is the cross-sectional length of the roof?

To do this you need to know the angle 25° is $\frac{25}{360}$ of the whole circle. The arc length will be $\frac{25}{360}$ of the circumference of the circle. That is:

$$\frac{25}{360} \times 2\pi r = \frac{25}{360} \times 2\pi \times 12$$

$$\approx 5.236$$

So the length of the roof will be about 5.24 metres.

Let's have a look at this in terms of radians. The angle 25° is about 0.44 radians.

Recall a radian is the ratio of an arc length to the radius. This means if the circle's radius was 1 metre, the arc length would be 0.44 metres. Since the radius is 12 metres, the arc length is 0.44×12 or 5.24 metres.

If the length of the radius of a circle was r units and an arc subtended an angle of θ radians, then the length of the arc would be $r \times \theta$ units.

So if we know the angle in terms of radians then it's just a matter of multiplying by the length of the radius – simple!

Remember:

$$\text{Arc Length} = \theta r$$

where θ is measured in radians and r is the radius of the circle.

Activity 4.4

1. A Toowoomba resident feels that the temperature variation in the city on a certain day can be modelled by the equation:

$$T = 10 + 8 \sin\left(\frac{\pi}{12}t\right)$$

where T is the temperature ($^\circ\text{C}$) at t hours after 9 a.m.

Using this equation, what should be the temperature at 2 p.m.?

2. The change in voltage produced by a mains electricity source is given by the formula:

$$V = 240 \sin(100\pi t)$$

where V is the size of the voltage in volts and t is the time in seconds since the power was connected.

- (a) Calculate the size of the voltage 1 second after switching on the power.
- (b) Calculate the size of the voltage 1.005 seconds after switching on the power.

3. A child wishes to make a fancy hat for herself. The hat is to be in the shape of a cone and is to be cut from a circle of radius 80 cm (see below):

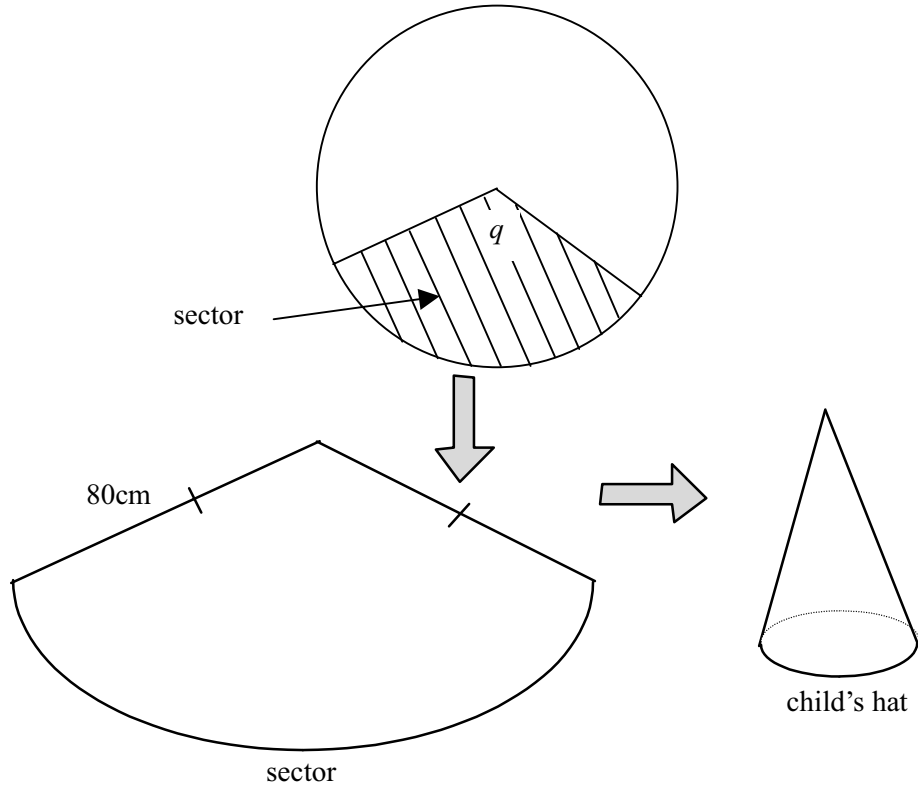

If the circumference of the child's head is 45 cm, then the length of the arc on the sector will also need to be 45 cm. Calculate the size of the angle q at the centre of the sector.

4. For the diagram below, calculate the radius of the sector, given that the length of the arc is 12 cm and the angle subtended by the arc is 35° .

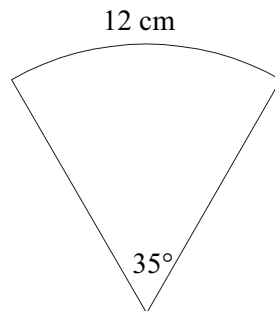

5. The second hand of a clock is 15 cm in length, calculate the arc length (to the nearest centimetre) along which the tip of the hand will travel in 14 seconds.
6. One of the students who attempted question 1 above originally obtained the incorrect result of 10.18°C for the temperature at 2 p.m. Write a short sentence explaining what error he made.

7. The house designer decides to design some window panels on the walls to imitate the curved roof. What will the area of these panels be if the angle is the same but the radius is now 3 metres? (Hint: the area of a full circle is πr^2 , but you only want a fraction of the full circle.)

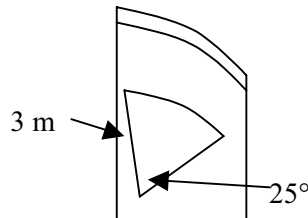

8. Develop a formula for the area of the sector of any circle if the angle was in radians.
9. The height in metres of the tide in a harbour entrance is given by
- $$h = 0.8 \cos \frac{1}{6} \pi t + 6.5,$$
- where t is the time in hours measured from high tide.
- (a) At 5 hours from high tide, what is the height of the tide?
- (b) When is the tide 2 metres?

Something to talk about...

Can you think of other examples like the simpler ones in this activity. Why not try to create your own exercise. Give it to your colleagues or the discussion group.

4.2 Graphs of sine, cosine and tangent functions

In unit TPP7182 or equivalent you should have graphed the trigonometric functions and be familiar with the concept of amplitude and period.

Recall:

The **amplitude** is half the distance between the maximum and minimum values of the function.

The **period** is the distance along the horizontal axis of one wave length (or the smallest complete curve that is repeated). In the diagram below the amplitude is 1 and the period is about 6.2.

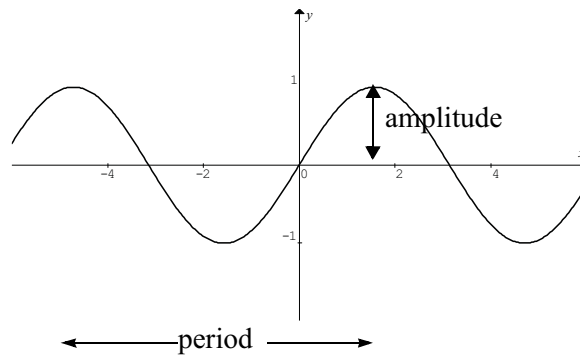

Let's look at these functions again using radian measure. There will be no difference between the shapes of the graphs drawn in each mode. The graphs will look the same except the units on the x -axis will be $0, \frac{\pi}{2}, \pi, \frac{3\pi}{2}, 2\pi$ etc. instead of $0, 90^\circ, 180^\circ, 270^\circ, 360^\circ$. Let's look at how to draw some graphs in radian mode. Graphmatica normally works in radians so this is relatively straightforward.

Example

Using Graphmatica, draw the graphs of the functions:

$$f(x) = y = \cos 2x \text{ and } g(x) = y = \cos 4x \text{ for } -2\pi \leq x \leq 2\pi .$$

Write a few sentences comparing the graphs of the two functions.

Figure 4.1: $f(x) = \cos 2x$ and $g(x) = \cos 4x$ for $-2\pi \leq x \leq 2\pi$

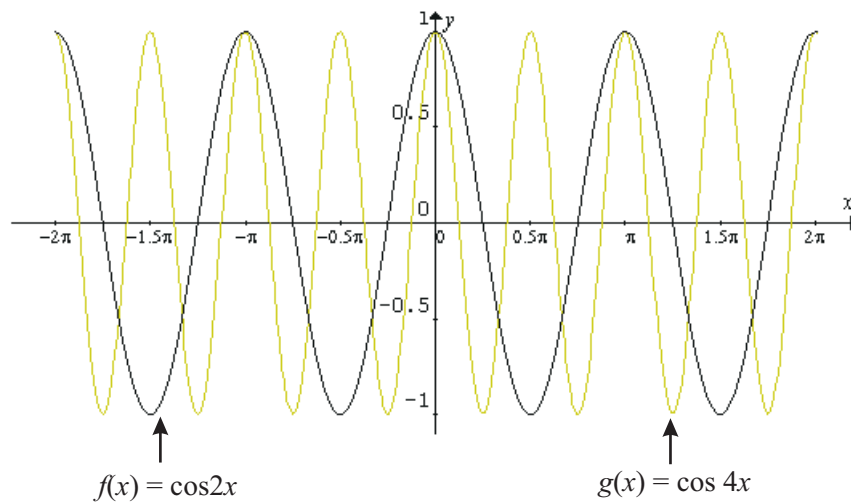

The graphs of $f(x)$ and $g(x)$ are very similar.

- The amplitudes are the same (i.e. half the height of the 'wave' is 1);
- the general shapes are the same and
- the y -intercept is the same.

However $g(x)$ oscillates much more quickly and the x -intercepts are different.

$$f(x) = \cos 2x \text{ has a period of } \pi$$

$$g(x) = \cos 4x \text{ has a period of } \frac{\pi}{2}$$

So doubling the coefficient of x halves the period. We will have a look at this in more detail later in this module.

Activity 4.5

- Using the domain $-2\pi \leq x \leq 2\pi$ draw the graph of:

$$y = \sin 3x$$

- Write a paragraph comparing the graphs of $y = \sin x$ and $y = \cos x$
- Using the domain $-2\pi \leq x \leq 2\pi$ draw the graph of the function $y = \tan x$. Is the curve periodic? When is the function discontinuous?
- On the same graph paper and using the domain $-2\pi \leq x \leq 2\pi$ draw the graphs of:
 - $f(x) = y = \sin x$ and $g(x) = y = 3 \sin x$
 - Write a short sentence explaining any differences.

4.3 Modelling using trigonometric functions

One of the important features of periodic functions is their ability to model various real world applications like electrical currents, pendulums, blood pressure, even the wings of insects over time. The way this is done is to change the numbers around x , our variable of interest in the equation $y = \sin x$. In the above example in figure 1, we had two functions $f(x) = \cos 2x$ and $g(x) = \cos 4x$. These functions differed by the coefficient of x . These numbers are variable, but we call them **parameters** to distinguish them from our main variable x . You have already come across parameters before. For example, in the general linear equation

$y = mx + c$, m and c are parameters and in the general quadratic equation $y = ax^2 + bx + c$, a , b and c are parameters. These parameters helped us model real life situations which followed a linear or parabolic pattern. Now, with the help of parameters, we will develop a general periodic equation which will help us model situations which follow a periodic pattern.

Look at the following equations. In each case t (the variable of interest) is time and we have given parameters specific values:

- in an electrical circuit, voltage across a component is given by $V = 7 \sin(18\,000t)$;
- current flowing through the component is $I = 5 \cos(18\,000t)$;
- a pendulum swinging is $x = 2.5 \sin(t - 0.284)$ [x is the distance from the vertical];
- a person's blood pressure is $P = 95 + 25 \cos(6t)$; and
- the angular displacement of the hindwings of a locust is $h = 1.5 + \sin\left(\frac{2\pi}{0.06}t\right)$.

In all of these examples, the basic shape will be very similar to the sine curve (often these curves are called **sinusoidal** – that is having the appearance of a sin curve (pronounced sigh-nu-soy-dal)). Can you see that they will all fit the general equation $y = a \sin(bx + c) + d$ or $y = a \cos(bx + c) + d$? Look at the voltage equation:

$V = 7 \sin(18\,000t)$ which could be written as:

$V = 7 \sin(18\,000t + 0) + 0$. Compare it to the general equation –

$\Downarrow \quad \Downarrow \quad \quad \Downarrow \quad \Downarrow \quad \Downarrow \quad \Downarrow$

$y = a \sin(b \quad x + c) + d$

Here $y = V$; $a = 7$; $b = 18\,000$; $x = t$; $c = 0$ and $d = 0$

Activity 4.6

For each equation below compare it to the general equation $y = a \sin(bx + c) + d$, or $y = a \cos(bx + c) + d$ and determine the values of the parameters a , b , c and d :

1. $y = 3 \sin(2x + 1) + 4$

2. $y = 5 \cos(2x - 2) - 12$

3. $y = 2.5 - \sin\left(\frac{x}{3}\right)$

4. $V = 12 \sin(20\pi t - 0.5)$

5. $D = 25 - \cos(3 - 2t)$

How do these parameters affect the shape of the graph? Let's have a look at these parameters and their effect on the main features of the graph.

Boats going into harbour need to know tide times so they can enter at the safest times. In a particular harbour the height of the tide (in metres) is modelled by the function

$h = 2.5 \sin\left(\frac{\pi}{6}t\right) + 5$ where t is the number of hours after midnight.

What effect do 2.5 , $\frac{\pi}{6}$, and 5 in the above equation have on the shape of the graph? Let's look at the simplest trigonometric function and then build on it. We will eventually create the boat function above.

Try and sketch (by hand) the function $y = \sin x$. Think about the main points before you actually sketch the curve. Don't worry if you cannot answer all these questions yet. Use a domain between -2.5π and 2.5π .

- What is the range of the function?
- Where does it cut the y -axis?
- Where does it cut the x -axis?
- What is the amplitude?
- What is the period?
- What are the 'turning points' or the maximum or minimum points?

You should have said:

The range is from -1 to 1

The y -intercept is the origin

The x -intercepts are when $\sin x = 0$ which is when $x = 0, \pi, 2\pi, -\pi$ etc.

The amplitude is 1

The period is 2π

The maximums occur when $x = \frac{\pi}{2}$, and $\frac{-3\pi}{2}$; the minimums occur when $x = \frac{3\pi}{2}$ and $-\frac{\pi}{2}$.

So your sketch should look like this:

Figure 4.2: $y = \sin x$

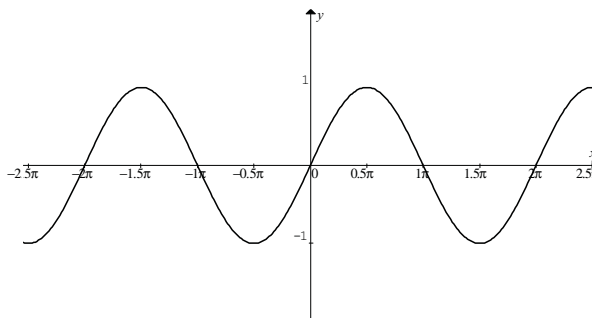

Now do this in Graphmatica. See if you can match the graph above.

4.3.1 Amplitude

In our boat function, $h = 2.5\sin\left(\frac{\pi}{6}t\right) + 5$, we multiplied the basic function $\sin x$ by 2.5.

Let's look at the effect of multiplying the basic function $y = \sin x$ by a constant. Sketch the graph of $y = 2.5\sin x$. Again look at the main points:

- What is the range?
- What are the intercepts?
- What is the amplitude?
- What is the period?
- What are the maximum and minimum points?

Your sketch should look like this:

Figure 4.3: $y = 2.5\sin x$

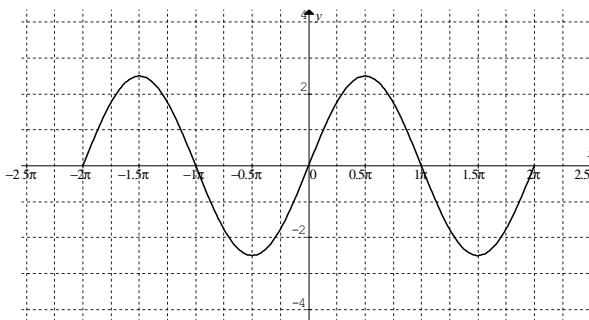

The period and the x - and y -intercepts remain the same. Can you see that multiplying the function by a constant increases the amplitude from 1 to 2.5 and extends the range from $-1, 1$ to $-2.5, 2.5$? The maximum points occur at $(0.5\pi, 2)$, $(2.5\pi, 2)$ etc. and the minimums at $(1.5\pi, -2)$, $(-0.5\pi, -2)$ etc.

In the general equation $y = a\sin(bx + c) + d$, the value of $|a|$ is the amplitude of the function. Since the amplitude is a distance, it is always positive.

Activity 4.7

1. What is the amplitude in each of the following functions:

(a) $y = 3 \sin(2x + 1) - 2$

(b) $y = 5 - 3 \cos x$

(c) $h = 12 + 0.5 \cos(2x)$

2. Examine the graphs of the functions below, and determine their amplitude.

(a)

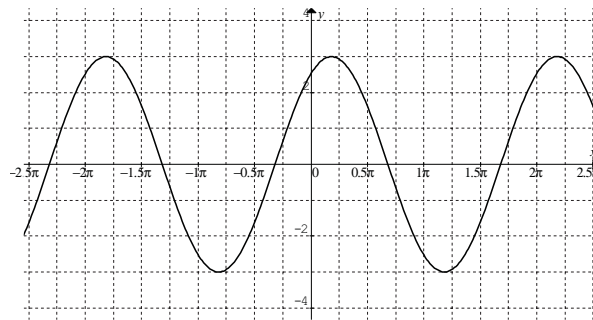

(b)

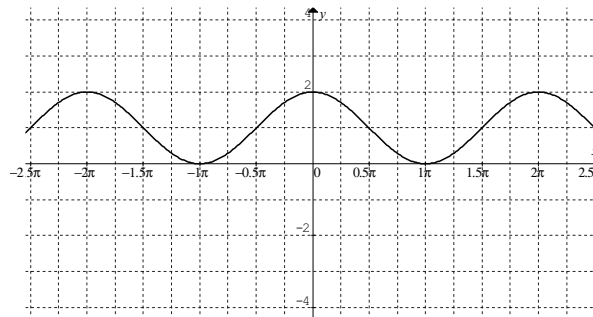

4.3.2 Vertical shift

In our boat function, $h = 2.5 \sin\left(\frac{\pi}{6}t\right) + 5$, we added 5 to the basic function of $\sin x$.

Imagine adding 5 to every value in the curve from our function in the previous section, $y = 2.5 \sin x$. The equation to the function is now $y = 2.5 \sin x + 5$.

Again ask yourself:

- What is the range?
- What are the x and y intercepts?
- What is the amplitude?
- What is the period?
- What are the maximum and minimum points?

Your sketch of the function should look like this:

Figure 4.4: $y = 2.5 \sin x + 5$

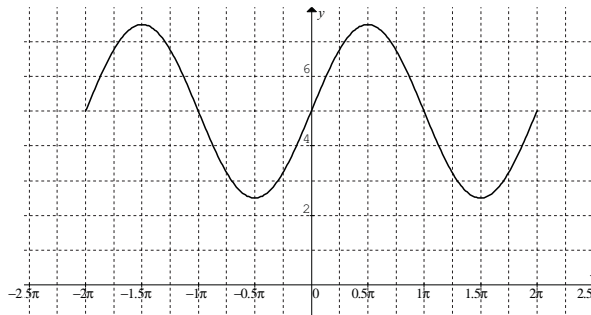

So adding a constant to the function moves the whole function up the vertical axis. This time the range is from 2.5 to 7.5 and the y -intercept changes to 5. There are no x -intercepts. The amplitude stays the same (2.5) as does the period (2π). The maximum points are $(0.5\pi, 7.5)$, $(2.5\pi, 7.5)$ etc. and the minimum points are $(1.5\pi, 2.5)$, $(-0.5\pi, 2.5)$ etc.

In the general formula $y = a \sin(bx + c) + d$ or $y = a \cos(bx + c) + d$, the d indicates the vertical shift of the function.

Activity 4.8

1. What is the vertical shift of the following functions?

(a) $y = 3 \sin(2x + 1) - 2$

(b) $h = 12 + 0.5 \cos(2x)$

2. Examine the graph of the function below, and determine its vertical shift.

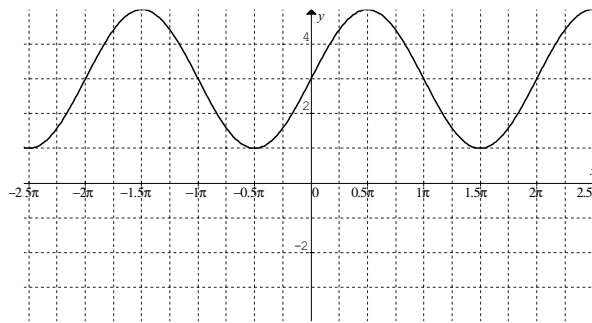

3. What is the amplitude of the graph in question 2?

4.3.3 The period of trigonometric functions

Let's look at what happens to the boat function $h = 2.5 \sin\left(\frac{\pi}{6}t\right) + 5$ if you multiply t by a constant.

As we saw in figure 4.1, when we compared $y = \cos 2x$ and $y = \cos 4x$, if we multiplied x by 2, this has the effect of halving the period, i.e. squashing up the graph. In the function:

$y = 2.5 \sin\left(\frac{\pi}{6}x\right) + 5$, if we multiplied the variable x by $\frac{\pi}{6}$ (0.524), we would spread out the

graph compared to the graph of $y = 2.5 \sin t + 5$. Draw the boat function in Graphmatica and see if you can identify the period.

Figure 4.5: $h = 2.5 \sin\left(\frac{\pi}{6}t\right) + 5$

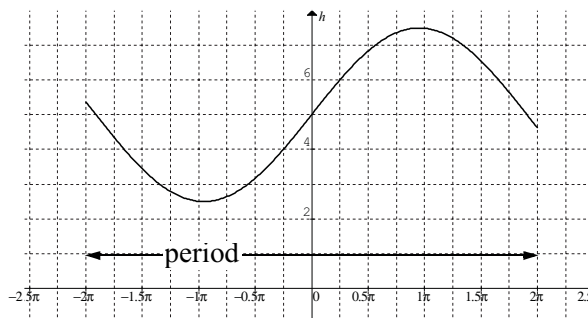

From figure 4.5 above, the period appears to be about 4π . The amplitude is still 2.5 and the vertical intercept is still 5. But what is the exact value of the period?

Let's look at some simpler functions. In Graphmatica, draw the graphs of the following functions and identify the period:

$$y = \sin x$$

$$y = \sin 2x$$

You should have drawn something like this:

Figure 4.6: $y = \sin x$ and $y = \sin 2x$

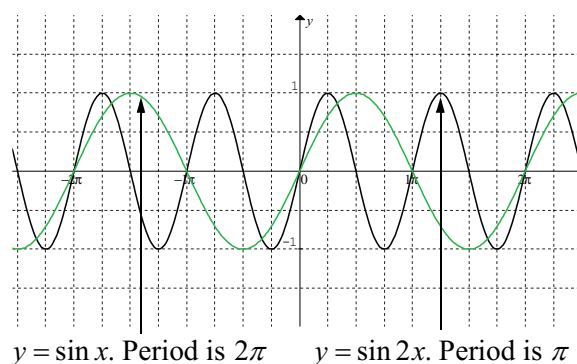

The graph of $y = \sin 2x$ oscillates more quickly than $y = \sin x$. If we double the coefficient of x we halve the period.

Now draw the graphs of:

$$y = \sin x$$

$$y = \sin \frac{1}{4}x$$

Figure 4.7: $y = \sin x$ and $y = \sin \frac{1}{4}x$

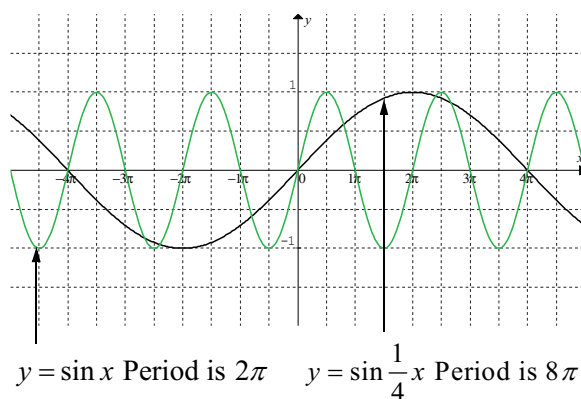

Can you write a sentence similar to the one above comparing these two graphs?

You should have said something like: *The graph of $\sin\frac{1}{4}x$ oscillates much more slowly than $y = \sin x$. If we divide x by 4 then we increase the period 4 times.*

Can you find a general relationship between the period and the equation of the graph?

If the equation of the function is $y = \sin x$ the period is 2π .

If the equation of the function is $y = \sin 0.25x$ the period is 8π (i.e. 2π divided by $\frac{1}{4}$).

If the equation of the function is $y = \sin 2x$ the period is π (i.e. 2π divided by 2).

If the equation of the function is $y = \sin\frac{\pi}{6}x$ the period of the function is 12 (i.e. 2π divided by $\frac{\pi}{6}$).

If the equation of the function is $y = \sin nx$, what would the period be?

You should have said the period of the function $y = \sin nx$ is $\frac{2\pi}{n}$.

In the boat equation $h = 2.5\sin\left(\frac{\pi}{6}t\right) + 5$, the coefficient of the t is $\frac{\pi}{6}$, so the period is $2\pi \div \frac{\pi}{6}$ or 12.

Look back at the graph of the function to check that 12 matches one complete cycle. (Of course – high tide comes around every 12 hours!)

Now let's go back to the general equation of a sine curve $y = a\sin(bx + c) + d$. The coefficient of x is b , so the period will be $\frac{2\pi}{b}$, or more correctly $\left|\frac{2\pi}{b}\right|$ since the period is a distance.

In the general equation $y = a\sin(bx + c) + d$, the period is $\left|\frac{2\pi}{b}\right|$

Let's look over all we know about our boat function. Using your graphing package and setting an appropriate domain and range, draw the graph of $h = 2.5\sin\left(\frac{\pi}{6}t\right) + 5$. You know:

- The amplitude is 2.5
- The vertical shift is 5
- The period is 12
- The h intercept is 5

In this case the domain is the number of hours after midnight so you only need x between 0 and 48 say (i.e. 2 days). Put the horizontal axis in rectangular mode by clicking in the View/Graph Paper section.

Figure 4.8: Height of tide over time $h = 2.5 \sin\left(\frac{\pi}{6}t\right) + 5$

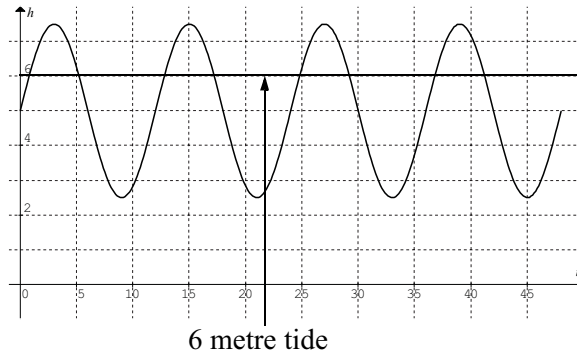

When is the height of the tide 6 metres?

From the graph it looks like it is at about 1 a.m.; 5 a.m.; 1 p.m. and 5 p.m. etc.

The period of a function can be quite useful. For example if you know one x -intercept, adding the period will give you another. If you know one maximum value of x , adding the period will give you another.

In our example of the toy elephant the equation was $L = 12 + 2.5 \cos 2\pi t$. We found the spring would be 12 cm long after 0.25 secs. The period is $1\left(\frac{2\pi}{2\pi}\right)$, so the length of the spring will be 12 cm long after 0.25 secs and every second after that or after 1.25 secs, 2.25 secs, 3.25 secs etc. Note it will also be 12 cm long after 0.75 secs (0.25 + half the period or 0.5 seconds – since it's half way up the curve) and every second after that as well. You can see this more clearly on a graph of the function. (To draw this in Graphmatica, change the graph paper to rectangular instead of trig view, and change the labels on the axes to t and L .)

Figure 4.9: $L = 12 + 2.5 \cos 2\pi t$

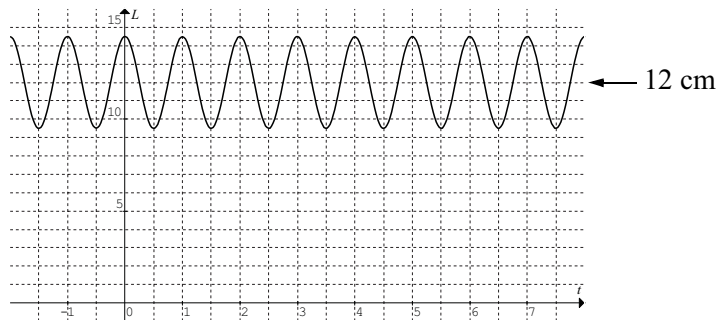

Activity 4.9

- What is the period of the function $y = 3\sin(\pi x + 1)$?
- Draw the graphs of the following functions and then determine their period.
 - $y = \cos x$
 - $y = \cos 2x$
 - What would be the general rule for determining the period of a cosine function (i.e. is the period of the function $y = \cos bx$)?
- Draw the graphs of the following functions and then determine their period.
 - $y = \tan x$
 - $y = \tan 2x$
 - What would be the general rule for determining the period of a tangent function (i.e. that is the period of the function $y = \tan bx$)?
- Graph the function $f(x) = \sin x$. Now on the same graph draw $g(x) = \sin(x + 4)$.
 - What is the period of $g(x)$?
 - Write a sentence comparing $f(x)$ and $g(x)$.
- Determine the period of:
 - $y = 2.5\cos x$
 - $L = 12 + 2.5\cos 2\pi t$
 - $h = 3\tan\left(\frac{5t}{3}\right)$
- Examine the graphs of the periodic functions shown below and determine their period:
 -

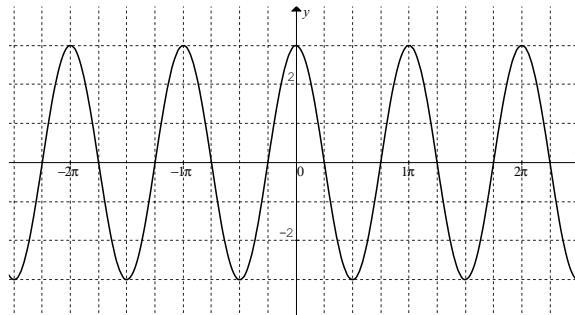

(b)

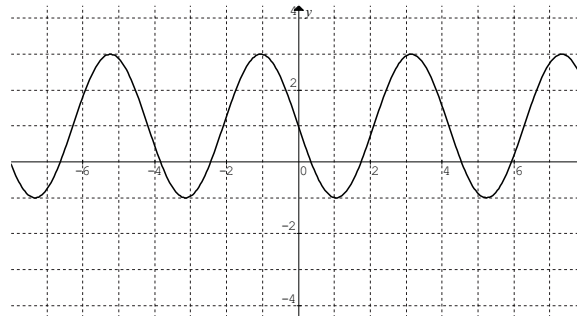

4.3.4 The phase of trigonometric functions

The last parameter we will look at in the general equation $y = a \sin(bx + c) + d$, is the c .

Let's go back to the toy elephant on a spring. We can graph the function of length of spring with respect to time ($L = 12 + 2.5 \cos 2\pi t$) for the first 5 seconds.

Figure 4.10: $L = 12 + 2.5 \cos 2\pi t$

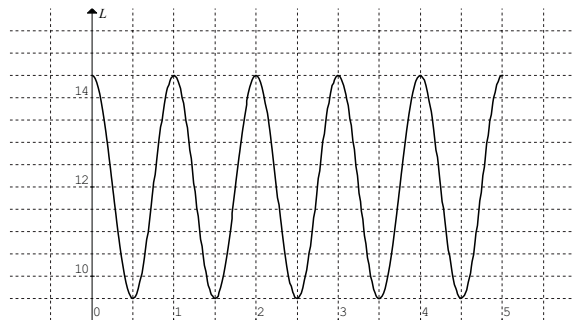

What is happening at $t = 0$? Here the length of the spring is at the maximum stretch. What if we held the elephant so the spring was not stretched or compressed? At time zero, the length of the spring would be 12 cm. This would still be the mid-point of the function (between the maximum and minimum values) so the curve will have to cut the x -axis at $(0, 12)$. We would have to change the formula to $L = 12 + 2.5 \cos(2\pi t + \frac{\pi}{2})$, since when $t = 0$, $\cos(2\pi t + \frac{\pi}{2})$ becomes 0 and L becomes 12. If we drew this new graph and compared it to the previous one, it would look like the one below.

Figure 4.11: $L = 12 + 2.5 \cos 2\pi t$ and $L = 12 + 2.5 \cos(2\pi t + \frac{\pi}{2})$

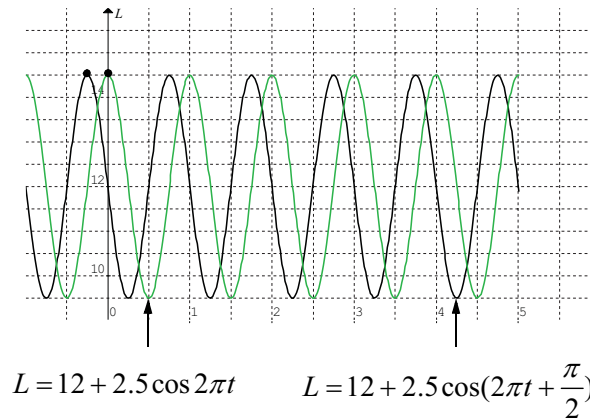

Can you see what has happened to the graph? It has shifted back **one quarter** of a second. Pick a point on the original graph, say $(0, 14.5)$. It is now $(-0.25, 14.5)$.

If you had said it moved forward $\frac{3}{4}$ of a second, you would be right as well since

$\cos(2\pi t - \frac{3\pi}{2}) = 0$ as well. In fact, we could move our initial curve back or forward to many different positions and still have the point $(0, 12)$ on the curve.

What if we had changed the graph to $L = 12 + 2.5 \cos(2\pi t + \frac{3\pi}{2})$?

Figure 4.12: $L = 12 + 2.5 \cos 2\pi t$ and $L = 12 + 2.5 \cos(2\pi t + \frac{3\pi}{2})$

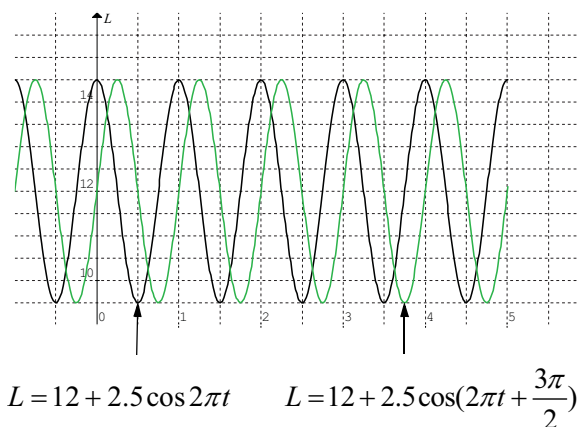

Now the graph has shifted back **three quarters** of a second.

Again if we had shifted it forward $\frac{1}{4}$ of a second we would get the same curve.

Here $\cos(2\pi t - \frac{\pi}{2}) = 0$.

If we changed the function to $L = 12 + 2.5 \cos(2\pi t + 2\pi)$, could you guess how far back the curve would move?

If you said 1 second, you would be right. Let's look at this on the graph.

Figure 4.13: Graph of $L = 12 + 2.5 \cos(2\pi t + 2\pi)$

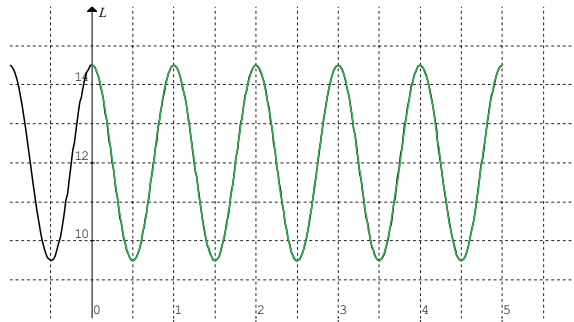

Drawing it on Graphmatica shows the 2 curves are **coincident**. (i.e. one lies on top of the other)

The size of the shift in the curve is called the **phase shift**.

How does this fit into the equation of the general cosine function?

$y = a \cos(bx + c) + d$. The c is the parameter we are changing. But c alone does not give us our phase shift. However, if we divide this parameter by b , then we get the phase shift. In the example above

$$L = 12 + 2.5 \cos(2\pi t + \frac{\pi}{2}), c = \frac{\pi}{2} \text{ so the phase shift is } \frac{\pi}{2} \div 2\pi = \frac{\pi}{2} \times \frac{1}{2\pi} = \frac{1}{4}$$

$$L = 12 + 2.5 \cos(2\pi t + \frac{3\pi}{2}), c = \frac{3\pi}{2} \text{ so the phase shift is } \frac{3\pi}{2} \div 2\pi = \frac{3\pi}{2} \times \frac{1}{2\pi} = \frac{3}{4}$$

$$L = 12 + 2.5 \cos(2\pi t + 2\pi), c = \frac{\pi}{2} \text{ so the phase shift is } 2\pi \div 2\pi = 1$$

If we shifted the curve **forward** by 2, then $c = 2\pi \times -2 = -4\pi$ and the above equation would become $L = 12 + 2.5 \cos(2\pi t - 4\pi)$.

In the general equation of the curve $y = a \sin(bx + c) + d$, or $y = a \cos(bx + c) + d$ the phase shift is $\frac{c}{b}$ i.e. the curve is similar to $y = a \sin bx + d$ or $y = a \cos bx + d$ except it is shifted horizontally to the left or right. The sign determines the direction of the shift. If the sign is positive the shift is to the left, if it is negative the shift is to the right.

Example

Determine the phase shift for the equation $y = 0.076 \sin\left(\frac{\pi t - 5\pi}{7}\right)$

Rearranging the equation into the form of the general equation $y = a \sin(bx + c) + d$,

we have $y = 0.076 \sin\left(\frac{\pi t}{7} + \frac{-5\pi}{7}\right)$

So $c = \frac{-5\pi}{7}$ and $b = \frac{\pi}{7}$

The phase shift will be:

$$\begin{aligned} c \div b &= \frac{-5\pi}{7} \div \frac{\pi}{7} \\ &= \frac{-5\pi}{7} \times \frac{7}{\pi} \\ &= -5 \end{aligned}$$

The graph of $y = 0.076 \sin\left(\frac{\pi t - 5\pi}{7}\right)$ is 5 units out of phase with the general sine graph, so is 5 units to the right of the sine graph.

If we draw the graphs of $y = 0.076 \sin\left(\frac{\pi t - 5\pi}{7}\right)$ and $y = 0.076 \sin\left(\frac{\pi t}{7}\right)$ this should confirm our answer.

Figure 4.14: $y = 0.076 \sin\left(\frac{\pi t}{7}\right)$ and $y = 0.076 \sin\left(\frac{\pi t - 5\pi}{7}\right)$

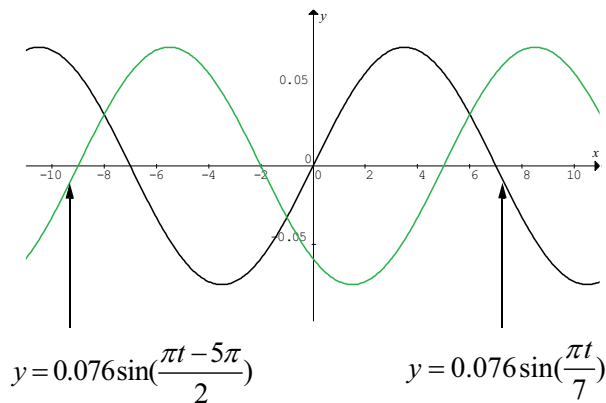

Activity 4.10

1. (a) Determine the phase shift for each of the functions below.
 - (b) Using Graphmatica, draw the graphs of the function and a similar function without the phase shift.
 - (i) $y = -\cos(x + 2)$
 - (ii) $y = 12 \sin(3x + 2)$
 - (iii) $h = 12 - \cos\left(\frac{t + 4}{5}\right)$
 - (iv) $y = \sin\left(\frac{\pi}{2} - x\right)$
2. On the same graph paper and using the domain $-2\pi \leq x \leq 2\pi$, draw the graphs of:
 - (a) $y = \cos x$ and $y = \sin\left(x + \frac{\pi}{2}\right)$
 - (b) Write some sentences explaining your results.

Summarising, we have seen that in the general formula $y = a \cos(bx + c) + d$ or $y = a \sin(bx + c) + d$

- a represents the **amplitude** of the function
- d represents the **vertical shift** of the function
- $\frac{2\pi}{b}$ represents the **period** of the function
- $\frac{c}{b}$ represents the **phase shift** of the function

Let's now use this information to create periodic equations.

Example

A function has an amplitude of 2 metres, a period of 10 seconds and is 2 seconds out of phase (has been shifted to the right) with the general sine curve. What is the graph of the function?

The amplitude is 2 so $a = 2$;

The period is 10 so $b = \frac{2\pi}{10}$ (since period = 10 = $\frac{2\pi}{b}$)

Phase shift is 2 so:

$$\begin{aligned}\frac{c}{b} &= -2 \\ c &= -2 \times \frac{2\pi}{10} \\ &= -\frac{2\pi}{5}\end{aligned}$$

If we use y as the dependent and x as the independent variables, the equation could be:

$$y = 2 \sin\left(\frac{\pi}{5}t - \frac{2\pi}{5}\right)$$

Example

From the graph of the periodic function below, find a sine equation to represent the function.

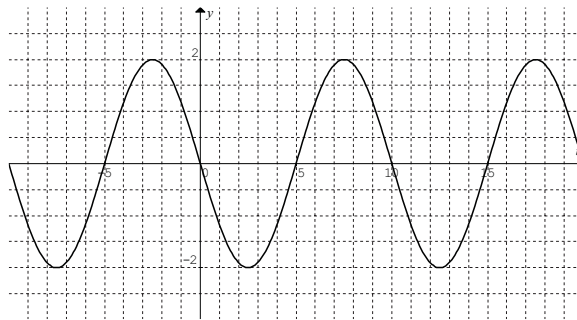

From the graph you can see the amplitude is 2, the period is 10 and the phase shift is -5 (or you could say $+5$).

$$\begin{aligned}\text{So } a &= 2 \\ b &= \frac{2\pi}{10} \\ c &= -5 \times b \\ &= \frac{2\pi}{10} \times -5 \\ &= -\pi\end{aligned}$$

So the equation is $y = 2 \sin\left(\frac{\pi}{5}t - \pi\right)$.

If you said the phase shift was $+5$, then the equation would be $y = 2 \sin\left(\frac{\pi}{5}t + \pi\right)$.

Activity 4.11

1. A function has an amplitude of 1.5 metres, a period of 4 seconds and is 0.25 seconds out of phase (to the right) with the general sine curve. What is the equation of the function?
2. From the graph of the periodic function below, find a cosine equation to represent the function.

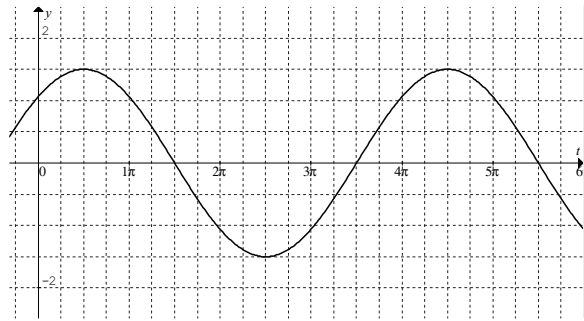

4.4 Inverse functions

In many instances in science and engineering, if we have an equation to a function, such as $y = \sin x$, we may be given y and need to find x . This was true in the example of the toy elephant $L = 12 + 2.5 \cos 2\pi t$ where we had to find the time (t) when the spring was 12 cm long. Let's now look at this in more detail.

You should be aware of inverse functions from module 3 and your study of TPP7182 or other mathematics studies. If you are unsure of inverses you will need to do some revision.

Remember if we had equation $0.4 = \sin x$, how could we find x ?

Written in another way $x = \sin^{-1} 0.4$ (or $x = \arcsin 0.4$).

Note: Arcsin is just another way of saying $\sin^{-1} x$. It comes from the idea that an angle can be measured in terms of the **arc** of a circle.

Using your calculator, $x = \sin^{-1} 0.4$ gives an angle of 0.41 radians (or 23.6°). There are an infinite number of solutions to this equation e.g. $(\pi - 0.41)$ radians, $(2\pi + 0.41)$ radians etc. (156.4° , 383.6° etc.). The function $y = \sin x$ is an example of a many-to-one function (i.e. there are many values of the independent variable, which map on to the same value for the dependent variable). The diagram below shows this clearly. Run a horizontal line across the function. If it cuts it in more than one place, it is a many-to-one function.

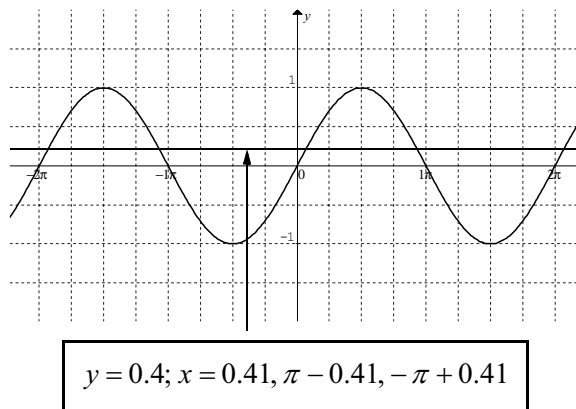
Figure 4.15: $y = \sin x$ 

We can also see this if we drew the graph of the equation $y = \sin^{-1} x$ on graph paper except there would be many values of y for each value of x . Let's look at this graphically.

In Graphmatica, draw the graph of $y = \sin^{-1} x$ (you can type in $y = a \sin x$). You should get something like figure 4.16 below. Notice it has drawn the relation over a limited range, i.e. the range that makes the relation a function

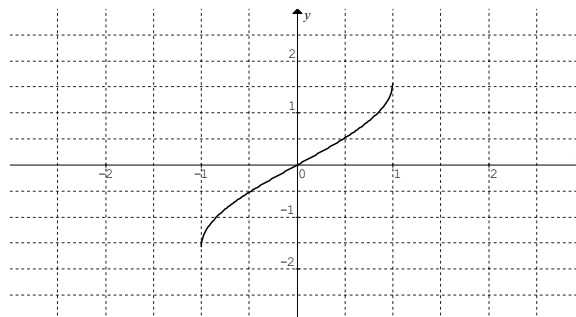
Figure 4.16: $y = \sin^{-1} x$ 

In this case the range is $-\frac{\pi}{2} \leq y \leq \frac{\pi}{2}$ or $(-1.57 \leq y \leq 1.57)$. Now consider the function

$y = \sin x$ with domain $-2\pi \leq x \leq 2\pi$. If we had to take the inverse of this function then the range of $y = \sin^{-1} x$ would be $-2\pi \leq y \leq 2\pi$ and the relation would no longer be a function. Graphmatica cannot not draw such relations. On figure 4.16 above draw what you would think it would look like.

Did you get a sketch like the one below in figure 4.17?

Figure 4.17

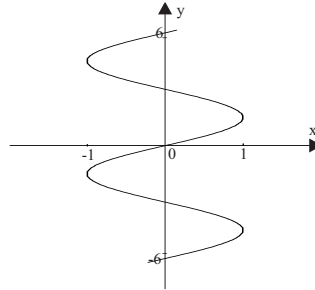

Notice for each value of x there are often 2 values for y . From the graph in figure 4.17, fill in the table below.

x	-1	-0.7	-0.5	-0.2	-0.1	0	0.1	0.2	0.5	0.7	1
y											
or y											

Did you get something like this?

x	-1	-0.7	-0.5	-0.2	-0.1	0	0.1	0.2	0.5	0.7	1
y	-1.6	-0.8	-0.5	-0.2	-0.1	0	0.1	0.2	0.5	0.8	1.6
or y		-3.9	-3.7	-3.3	-3.2	0	3.0	3	2.6	2.4	

If you used Graphmatica to draw $y = \cos^{-1} x$ (typing in $x = \cos y$ or $y = \text{acos } x$) what do you predict the range to be?

If you said from 0 to π you would be right, (see figure 18 below) since it is in this range that there is only one y value for each x value.

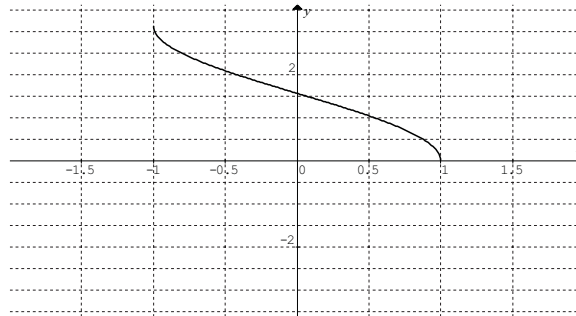
Figure 4.18: $y = \cos^{-1} x$ 

You may have said from $-\pi$ to 0 . While this also gives a function, by convention we use the range between 0 and π .

Example

What is the range for the function $y = \sin^{-1}(2x)$?

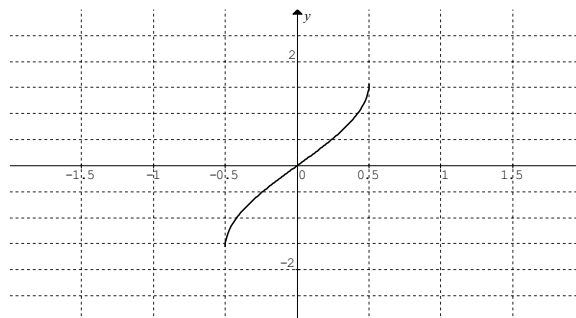
Figure 4.19: $y = \sin^{-1}(2x)$ 

The range is from $-\frac{\pi}{2}$ to $\frac{\pi}{2}$ (or -1.57 to 1.57).

Activity 4.12

- Sketch the graph of $y = \tan^{-1} x$ by hand (this will give you a good ‘feel’ for what the characteristics of the graph are) for $-8 \leq x \leq 8$.
- Draw the graph of $y = \tan^{-1} x$ in Graphmatica.
 - Use the graph in (a) to find y if x is the following:
 - $x = 1.2$
 - $x = 4$
 - Estimate the value of y when $x = 167$. Use the Point Evaluate menu to check your answer on Graphmatica.
- Sketch the graph of $y = \cos^{-1} x$ for $-2\pi \leq y \leq 2\pi$ using figure 4.18 as a guide.

4.5 Solving trigonometric equations

When you began to study algebra, you were asked to solve equations such as $4 = 3x + 5$. Gradually, you built up expertise to be able to solve more complicated equations like $x^2 + 3x - 6 = 0$. You saw the relationship between single variable equations and functions, for example $f(x) = x^2 + 3x - 6$, where solving the equation $x^2 + 3x - 6 = 0$ gave the roots of the function. This assisted you to see functions graphically. You were also asked to solve simultaneous equations, both algebraically and graphically. We want you to now build on this expertise to solve trigonometric equations. You will combine some trigonometric with non-trigonometric equations and you will now see that some equations can be solved algebraically while others cannot, and must be solved graphically.

First let's have a look at the following example.

Example

Two removalists are trying to carry a wardrobe (1.5 metres wide and 2.2 metres high) through a doorway. Unfortunately the height of the doorway is lower than the height of the wardrobe. At what angle must the wardrobe be tilted to get it through the doorway?

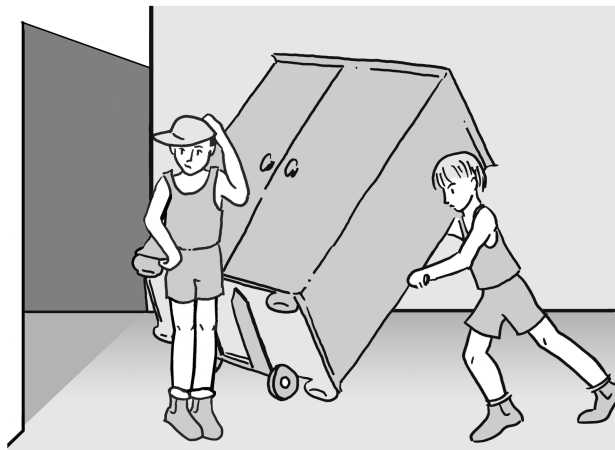

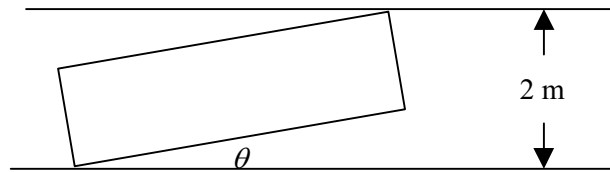

From the diagram above it can be shown that $2.2\sin\theta + 1.5\cos\theta = 2$. (For your interest, see method on facing page)

But how can we solve this equation? Just like quadratic equations, when we needed a method to solve $ax^2 + bx + c = 0$, we need some more rules to help us solve trigonometric equations. These rules are called trigonometric identities.

You already know some trigonometrical identities (although we have not called them this so far), for example:

- $\tan x = \frac{\sin x}{\cos x}$
- $\sin(180^\circ - x) = \sin x$ or $\sin(\pi - x) = \sin x$
- $\cos(360^\circ - x) = \cos x$ or $\cos(2\pi - x) = \cos x$
- $\tan(180^\circ + x) = \tan x$ or $\tan(\pi + x) = \tan x$
- $\sin^2\theta + \cos^2\theta = 1$

First let's practice solving some simple trigonometric equations both algebraically and graphically.

Example

If $3\cos x = 2$; $0 \leq x \leq 2\pi$, find x algebraically and graphically.

$$3\cos x = 2$$

$$\cos x = \frac{2}{3}$$

$$x = \cos^{-1}\left(\frac{2}{3}\right)$$

$$x \approx 0.8411 \text{ or } 2\pi - 0.8411 \approx 5.4421$$

(since $\cos x = \cos(2\pi - x)$)

For interest only.

A wardrobe was tilted to go through a two metre doorway as in the diagram below. To find the angle θ , consider the two shaded triangles.

You do not have to learn this!

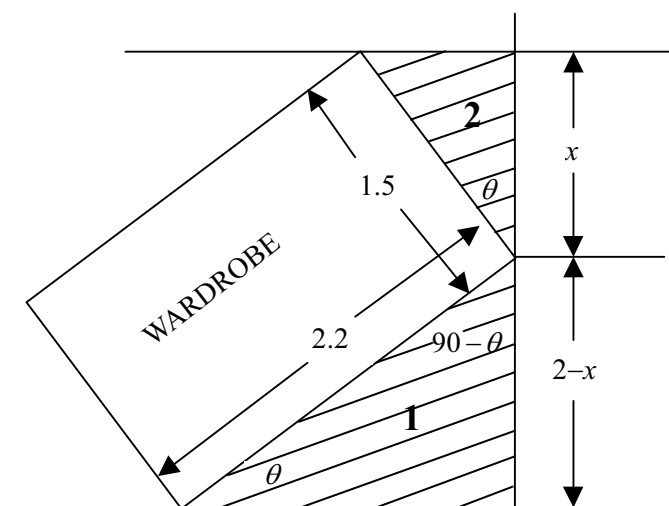

In triangle 1

$$\sin \theta = \frac{2-x}{2.2}$$

$$2.2 \sin \theta = 2-x$$

$$x = 2 - 2.2 \sin \theta$$

Substitute for x in triangle 2

In triangle 2:

$$\cos \theta = \frac{x}{1.5}$$

$$\cos \theta = \frac{2 - 2.2 \sin \theta}{1.5}$$

$$1.5 \cos \theta = 2 - 2.2 \sin \theta$$

$$2.2 \sin \theta + 1.5 \cos \theta = 2$$

Now we just need to solve this equation!

Draw the graph of $y = 3 \cos x$

Figure 4.20: $y = 3 \cos x$

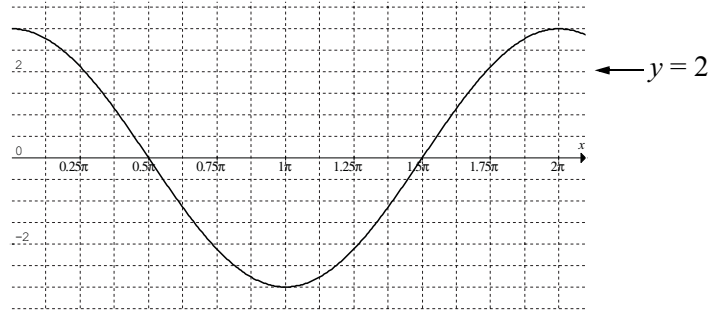

From the graph you can see when $y = 2$, $x \approx 0.26\pi$ or 1.74π . (Using the Coordinate Cursor gives 0.84 and 5.4.)

Example

When does $\sin x = \cos x$?

We could look at this graphically. If we look at the functions $y = \sin x$ and $y = \cos x$, the points where they intersect will give the approximate value of x .

Figure 4.21: $y = \sin x$ and $y = \cos x$

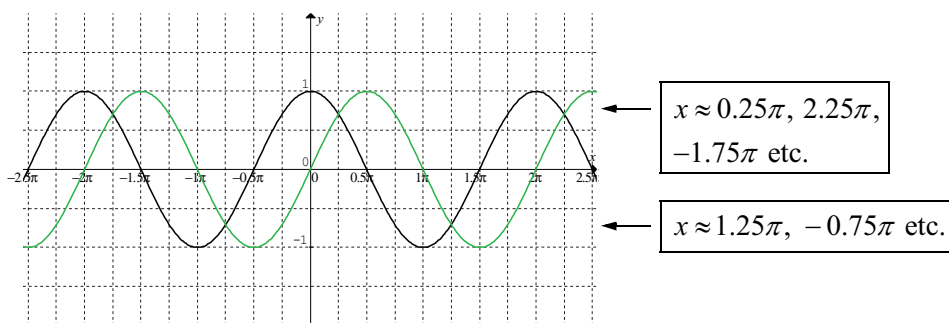

You can find the points of intersection by using the point menu.

It looks like some solutions will be 0.25π , 1.25π , -0.75π etc.

We could also solve this algebraically.

$$\sin x = \cos x$$

$$\frac{\sin x}{\cos x} = 1$$

$$\tan x = 1$$

$$x = \tan^{-1} 1$$

$$\approx 0.785$$

$$\text{Since } \frac{\sin x}{\cos x} = \tan x$$

Remember this is only one answer.

0.785 is about 0.25π .

If you substitute 0.785 into $\sin x = \cos x$ the statement is true. From looking at the graph you can see it will also be true if you add 2π (one period of sine or cosine) to the result (i.e. $0.25\pi + 2\pi = 2.25\pi$ or 7.069), and if you add π (half a period) to the result (i.e. 1.25π or 3.93).

Activity 4.13

1. Solve the following equations (algebraically and graphically) over the domain: $0 < x < 2\pi$

(a) $\sin x = \frac{1}{2}$

(b) $\cos x = 0.72$

(c) $\sqrt{2} \cos x - 1 = 0$

2. In question 1 of activity 4.4, the temperature in Toowoomba on a certain day was modelled by the equation:

$$T = 10 + 8 \sin\left(\frac{\pi}{12} t\right)$$

where T is the temperature ($^{\circ}\text{C}$) at t hours after 9 am.

At what time(s) should the temperature be 15°C in the next 24 hours?

3. In Physics, the study of the motion of projectiles reveals that the range of a projectile is given by the formula:

$$d = (V \cos \theta)t$$

where d is the horizontal distance (i.e. the range) travelled by the projectile; V is its launch velocity; θ its angle of launch; and t the time that it is in flight.

Consider the following scenario: an interballistic missile is launched from a frigate with a launch velocity of 200 m/s. The missile has to strike a target 2km away in 20 seconds in order to avoid the target striking the frigate first. What angle of launch is required to succeed in this mission? (see diagram below)

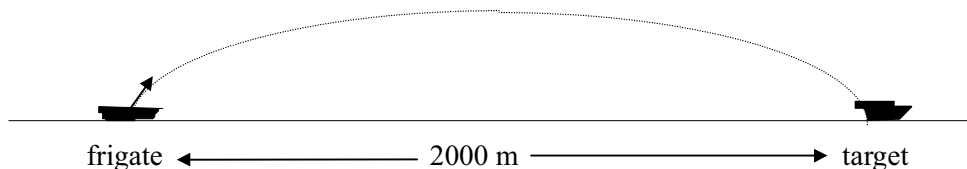

4. Use your calculator to evaluate the following expressions:

(a) $\cos^2 0.71 + \sin^2 0.71$ (make sure your calculator is set on radians)

(b) $\sin^2 20^{\circ} + \cos^2 20^{\circ}$ (change your calculator to degree mode for this question)

5. (a) Use Graphmatica to draw the functions $f(x) = \sin^2 x$ and $g(x) = \cos^2 x$ on the same grid. For each x -value determine the y -value for each function and then add these together. So, for example at $x = 0$, the graph tells us that $f(0) = 0$ and $g(0) = 1$ and the sum of these is $0 + 1 = 1$. Repeat this process for a number of x -values and you should always obtain 1.
- (b) Now on the same graph draw the function $y = \sin^2 x + \cos^2 x$. What do you predict the graph will look like?

Before we finish this module let's look at how we can use these identities we know to solve some more difficult equations. Just like ordinary equations we can solve them graphically as well. These may be a bit challenging for you at first. Don't worry. While you should have the mathematical tools to solve these equations, sometimes it's a bit difficult to collect all the right tools together! In these examples we want to use two tools.

- The first tool uses the idea that if $a = b$ then $a^2 = b^2$. This is called squaring both sides of an equation.
- The second tool uses the idea of substitution when equations become too complex. So if I have an equation like $\sin^2 x + \sin x = 1$, I could say let $a = \sin x$, then my equation becomes $a^2 + a = 1$ which is much easier on the brain. Look at the following examples to see how these tools are used.

Example

Find x in the equation $2 \cos x + \sin x = 2$ for $0 \leq x \leq \pi$ and prove your solution is correct.

First rearrange the equation: $2 \cos x = 2 - \sin x$. Rearranging in this way allows us to draw two graphs. Now we could solve this graphically by drawing the graphs of $y = 2 - \sin x$ and $y = 2 \cos x$. Where they intersect, will be the solution.

Figure 4.22: $y = 2 - \sin x$ and $y = 2 \cos x$

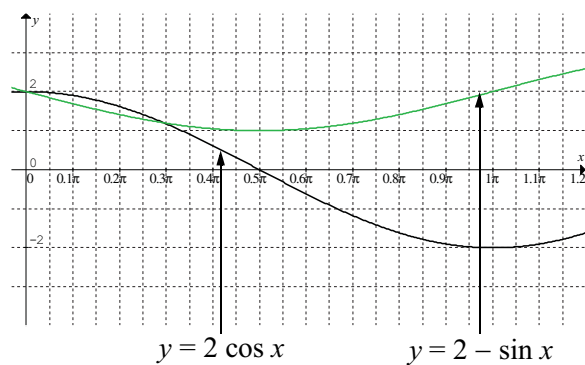

From the graph it appears the solutions are 0 and 0.3π .

Solving algebraically:

$$\begin{aligned}
 2 \cos x &= 2 - \sin x && \text{Square both sides} \\
 4 \cos^2 x &= (2 - \sin x)^2 && \\
 &= 4 - 4 \sin x + \sin^2 x && \text{Expand the quadratic expression} \\
 4(1 - \sin^2 x) &= 4 - 4 \sin x + \sin^2 x && \text{From our trig. identity, } \cos^2 \theta = 1 - \sin^2 \theta \\
 4(1 - a^2) &= 4 - 4a + a^2 && \text{Substitute } a \text{ for } \sin x \\
 4 - 4a^2 &= 4 - 4a + a^2 && \\
 0 &= -4a + 5a^2 && \text{Factorize to solve the equation} \\
 &= a(-4 + 5a) &&
 \end{aligned}$$

Therefore:

$$a = 0 \text{ or } -4 + 5a = 0$$

Substituting $\sin x = a$,

$$x = \sin^{-1} 0 \text{ or } x = \sin^{-1} 0.8$$

$$\sin x = 0 \text{ or } \sin x = \frac{4}{5}$$

$$x = 0 \text{ or } \pi \text{ or } x \approx 0.927$$

So between $x = 0$ and $x = \pi$, there appear to be three values which satisfy the equation $2 \cos x + \sin x = 2$, i.e. $x = 0$, π or $x = 0.927$. Looking at our graphical solution, 0 and 0.927 appear to be two correct solutions by π is not. If we substitute the values in the left-hand side of the original equation, we get the right hand side for values of 0 and 0.927 only.

$$2 \cos 0 + \sin 0 = 2 \times 1 + 0 = 2 \text{ (= Right-hand side)}$$

$$2 \cos 0.927 + \sin 0.927 = 2.0003 \text{ (= Right-hand side correct to 3 decimal places)}$$

$$2 \cos \pi + \sin \pi = -2 \text{ (} \neq \text{ Right hand side)}$$

So the only valid solutions are 0 and 0.927.

In this case we are not interested in the value of y , since it was not part of the original problem.

This example highlights the importance of checking your work. In this case it is important to sketch your graphs at first to see where you expect your solutions to lie and then to check your solutions in the original equation.

Notes:

- The reason we obtained three solutions was that in the algebraic solution, we squared both sides. There are other ways of solving this equation which you will study in future mathematics units.
- We could have drawn the graphs of $y = \sin x$ and $y = 2 - 2 \cos x$. You would have found the same solutions for x .

Example

Let's have a look at the wardrobe problem again. The equation we had to solve was $2.2\sin\theta + 1.5\cos\theta = 2$. Rearranging this equation gives $2.2\sin\theta = 2 - 1.5\cos\theta$.

So we can draw the graphs of:

$$y = 2.2\sin\theta$$

$$y = 2 - 1.5\cos\theta$$

In this example the domain is between 0° and 90° . (In this case we are using degrees, so we have to input it as $y = 2.2\sin(x \times \frac{\pi}{180})$ and change the grid range to an appropriate size to view the graphs.

Figure 4.23: $y = 2.2\sin\theta$ and $y = 2 - 1.5\cos\theta$

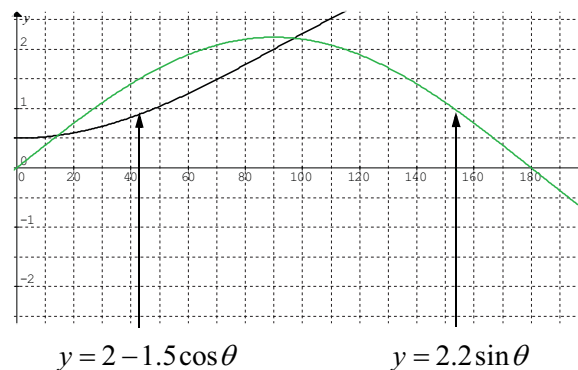

From the diagram, it looks like an angle of about 15° would allow the removalists to move the wardrobe.

Solving this algebraically:

$$2.2\sin\theta + 1.5\cos\theta = 2$$

$$2.2\sin\theta = 2 - 1.5\cos\theta$$

Square both sides

$$4.84\sin^2\theta = (2 - 1.5\cos\theta)^2$$

$$4.84(1 - \cos^2\theta) = (2 - 1.5\cos\theta)^2 *$$

$$\sin^2\theta = 1 - \cos^2\theta$$

$$4.84(1 - a^2) = (2 - 1.5a)^2$$

Substitute a for $\cos\theta$

$$4.84 - 4.84a^2 = 4 - 6a + 2.25a^2$$

$$0 = 7.09a^2 - 6a - 0.84$$

$$a = \frac{6 \pm \sqrt{36 - 4 \times 7.09 \times -0.84}}{2 \times 7.09}$$

$$\cos\theta \approx \frac{6 \pm 7.734}{14.18}$$

$$\approx 0.969 \text{ or } -0.122$$

$$\theta \approx 14.4^\circ \text{ or } 97^\circ$$

So the angle would be at most 14.4° . I think they should use straps to help them with this one otherwise they could get very sore backs!



** I can't seem to see these patterns – I am a bit confused!*

This is a common problem for many students learning mathematics – but this is what maths is all about – finding patterns. With trig functions look for the unknown. In this case it's θ . Now if there is a sin, cos or tan next to it – that's part of the term, so look at $\cos \theta$ as the unknown. Cos just by itself means nothing. Physically cross out $\cos \theta$ and put in something else, 'x' will do. So it looks like this:

$$0 = 7.09(\cancel{\cos \theta})^2 - 6\cancel{\cos \theta} - 0.84$$

$$\quad \quad \quad \downarrow \quad \quad \quad \downarrow$$

$$0 = 7.09x^2 - 6x - 0.84$$

You will be doing a lot more of this substitution as you do more maths. Don't worry it will become more automatic as you become more expert.

Example

Using Graphmatica, solve the following equation for x: $\sin x - e^{x-2} = 0$.

Rearranging, we get $\sin x = e^{x-2}$

Sketch the functions $y = \sin x$ and $y = e^{x-2}$ by hand roughly first to see what domain and range you want to set.

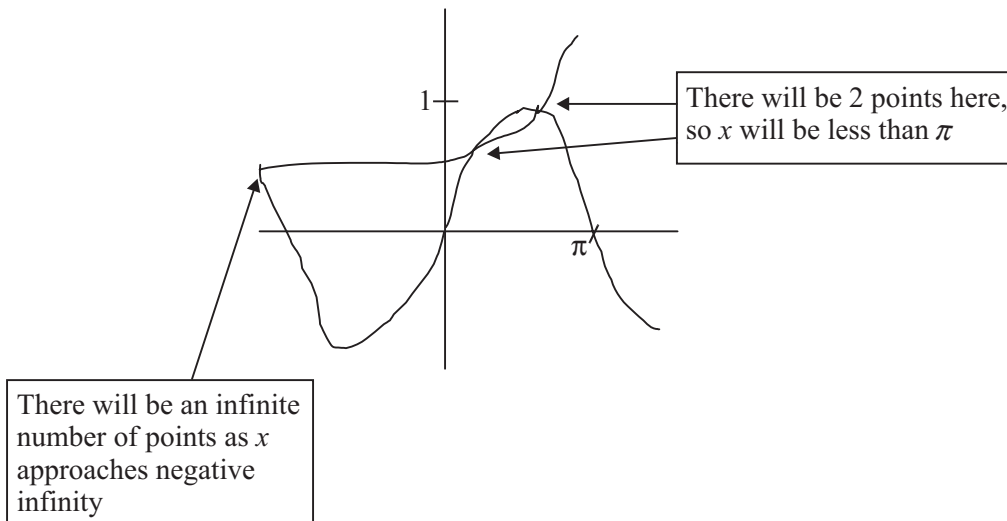

So set the domain between -2π and π .

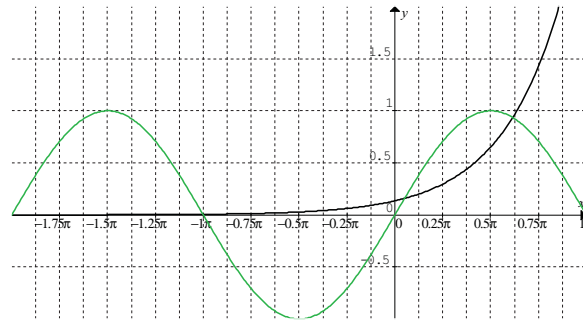
Figure 4.24: $y = \sin x$ and $y = e^{x-2}$ 

Using the point menu, you can find the values of x are 0.168 and 1.939.

As you do more mathematics, you will find other methods to solve equations such as these, but for the moment, the graphical technique is the only one available to you with the tools you have.

Activity 4.14

- Solve the following graphically and algebraically over the domain $0 \leq x \leq 2\pi$
 - $\sin x = \tan x$
 - $\sin x + \cos x = 1$ (hint: graph $y = \sin x$ and $y = 1 - \cos x$)
- Solve for x : $\sin 2x + 2x = 4$ (graphically)
- A student gave the following solution to the question:

Solve for x algebraically: $\sin 2x + \cos 2x = 5$

$$\sin 2x + \cos 2x = 5$$

$$\sin 2x = 5 - \cos 2x$$

$$(\sin 2x)^2 = (5 - \cos 2x)^2$$

$$1 - (\cos 2x)^2 = 25 - 10\cos 2x + (\cos 2x)^2$$

$$0 = 24 - 10\cos 2x + 2(\cos 2x)^2$$

$$0 = 12 - 5\cos 2x + (\cos 2x)^2$$

If I let $p = \cos 2x$, it makes the quadratic equation easier to understand.

$$0 = 12 - 5p + p^2$$

So

$$p = \frac{5 \pm \sqrt{25 - 4 \times 12}}{2}$$

$$p = \frac{5 \pm \sqrt{25 - 48}}{2}$$

$$p = \frac{5 \pm \sqrt{-13}}{2}$$

Now I am stuck! What is happening here?

If you had to mark this answer, what response would you give to the student?

4. In the equation $\sin x + \cos x = M$, what is the maximum value of M if the equation is to have any solutions. (Hint: graph $y = \sin x$ and $y = M - \cos x$ for appropriate values of M)

Something to talk about...

- Can you think of other questions like this that you could only solve graphically?
- Look at some more problems like $\sin x - e^{x-2} = 0$. Can you think of other questions like this that you could only solve graphically?

That's the end of this module, but not your final view of trigonometry. You will be using it in each of the next three modules. Hopefully we have provided examples so you can see the applications of mathematics in many diverse fields of science and engineering. Can you see the different parts of mathematics coming together and becoming dependent upon one another? You could not have completed this unit without algebraic and graphing tools, or the concept of function. As you do more mathematics this merging becomes more apparent, as Davis (*et al.*) states in the book *The Mathematical Experience*:

Unification, the establishment of a relationship between seemingly diverse objects, is at once one of the greatest motivating forces and one of the great sources of aesthetic satisfaction in mathematics. It is beautifully illustrated in a formula by Euler which unifies the trigonometric functions with the exponential functions...through series. (p. 214)

We can express $\sin x$ as a series:

$$\sin x = x - \frac{x^3}{3!} + \frac{x^5}{5!} + \dots$$

We can express the exponential as a series:

$$e^x = 1 + x + \frac{x^2}{2!} + \frac{x^3}{3!} + \dots$$

And with the addition of one special number i (which you haven't come across yet) you can put these together.

$$e^{ix} = \cos x + i \sin x \text{ where } i = \sqrt{-1}$$

When $x = \pi$, this leads to:

$$e^{i\pi} = \cos \pi + i \sin \pi = -1 \text{ or } e^{i\pi} + 1 = 0$$

There is, as Davis continues:

an aura of mystery in this last equation, which links the five most important constants in the whole of analysis: 0, 1, e, π , and i.

You certainly don't have to learn any of these last formulas, but I hope you are starting to appreciate the interrelatedness of the branches of mathematics.

Before you are really finished you should do a number of things.

1. Have a look at your action plan for study. Are you still on schedule? Do you need to restructure your action plan or contact your tutor to discuss any delays or concerns?
2. Make a summary of the important points in this module noting your strengths and weaknesses. Add any new words to your personal glossary. This will help with future revision.
3. Practice a few real world problems by having a go at 'A taste of things to come'.
4. Check your skill level by attempting the Post-test.
5. When you are ready, complete and submit your assignment.

The tail end...

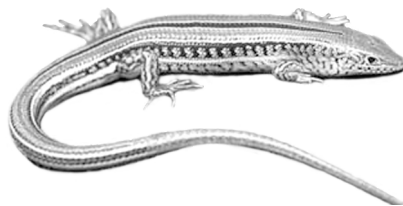

Remember at the beginning of the module we used a lizard's tail to show an application of trigonometric functions in science, the equation being

$$y = 0.257 - 0.09 \cos \frac{2\pi m}{12} + 0.064 \sin \frac{2\pi m}{12} - 0.049 \cos 2 \frac{2\pi m}{12}$$

You might wonder why anybody would want to model the amount of fat in a lizard's tail over a period of time. Well body fat is very important to lizards. They use it to survive their dormant period over winter and to have enough energy to reproduce in spring. The species of lizard in this study had even more problems as it only stores fat in its tail and as you know lizards will often shed their tail when grabbed by a predator. The model was developed so that we could estimate just how much fat a lizard stores at all times during the year. This was the first stage of determining whether they would be able to survive and reproduce after losing part of their tail. The good news is that as long as they only lose part of their tail, then they can happily survive to reproduce another day.

4.6 A taste of things to come

1. Alternating Signals

The currents and voltages in most electronic circuits vary with time. Some do so with a certain amount of regularity and are termed alternating currents (AC). The simplest alternating current is that which is based on the sine-wave and its current and voltage both vary sinusoidally (see diagram below):

Figure 4.25: $V = 2 \sin t$

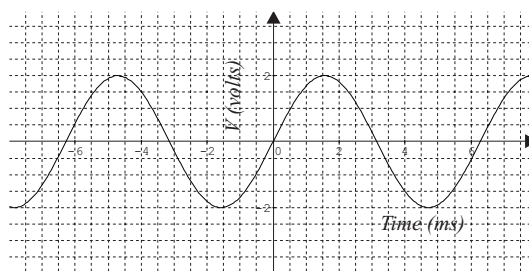

There are many other AC signals which are more complex, for example the square wave and the saw tooth wave (see below):

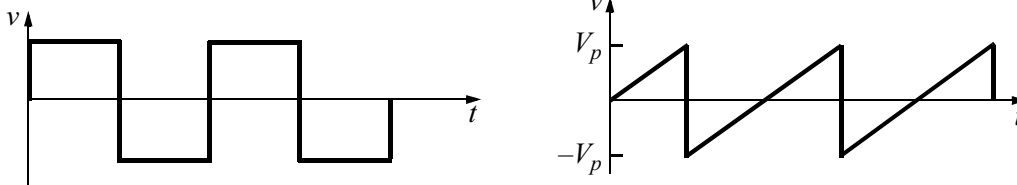

All of these AC signals can be formed through the summation of many separate sine waves. The function formed is called a **Fourier Series**.

(a) A square wave can be formed from the following Fourier series:

$$V = \sin(t) + \frac{1}{3}\sin(3t) + \frac{1}{5}\sin(5t) + \frac{1}{9}\sin(9t) + \dots$$

Using Graphmatica, draw the following graphs and note how the resulting wave becomes more and more like the square wave.

(i) $y = \sin x$

(ii) $y = \sin x + \frac{1}{3}\sin(3x)$

(iii) $y = \sin x + \frac{1}{3}\sin(3x) + \frac{1}{5}\sin(5x)$

(iv) $y = \sin x + \frac{1}{3}\sin(3x) + \frac{1}{5}\sin(5x) + \frac{1}{9}\sin(9x)$

Note: the resulting wave is close to a square wave, with the exception of the small peaks at either end of the square, these require a bit of electronic wizardry to eliminate.

(b) The saw-tooth signal can be formed from the following Fourier series:

$$V = \sin t - \frac{1}{2}\sin(2t) + \frac{1}{3}\sin(3t) - \frac{1}{4}\sin(4t) + \frac{1}{5}\sin(5t) + \dots$$

Use Graphmatica to draw the following graphs and note how the graphs progressively resemble the saw-tooth signal:

(i) $y = \sin x$

(ii) $y = \sin x - \frac{1}{2}\sin(2x)$

(iii) $y = \sin x - \frac{1}{2}\sin(2x) + \frac{1}{3}\sin(3x)$

(iv) $y = \sin x - \frac{1}{2}\sin(2x) + \frac{1}{3}\sin(3x) - \frac{1}{4}\sin(4x)$

(v) $y = \sin x - \frac{1}{2}\sin(2x) + \frac{1}{3}\sin(3x) - \frac{1}{4}\sin(4x) + \frac{1}{5}\sin(5x)$

2. Damped Harmonic Oscillations

If it were possible to eliminate the effects of friction altogether in child's swing, then after one small push the swing would continue forever. In such an ideal playground it is possible to show that the position of the swing relative to its starting position varies sinusoidally, so its graph may look like:

Figure 4.26: $d = 40\sin t$

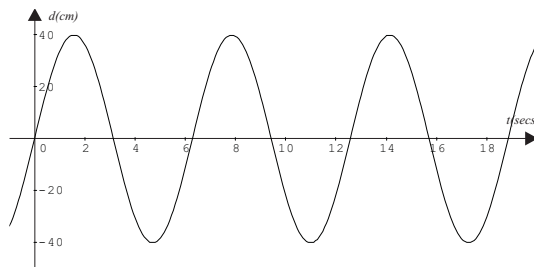

Such motion is called **simple harmonic motion** and you will encounter it in further studies, especially Physics. Of course such an ideal situation does not exist, as eventually the frictional forces will cause the swing to stop moving. In the real playground the motion of the swing can be best described as a '**damped** simple harmonic motion'. Graphically a damped simple harmonic motion could be described a sine wave bounded between two exponential functions. If you look at the graphs of such functions, you can imagine exponential functions being drawn above and below this function.

(a) Consider the damped simple harmonic motion function $y = e^{-0.1x} \sin(8x)$

- (i) Use Graphmatica to graph the function in the domain 0 to 20.
- (ii) On the same graph draw a graph of the functions $y = e^{-0.1x}$ and $y = -e^{-0.1x}$.
- (iii) If the function was used as a model for the swing, describe in words what is happening to the swing.

Notice the amplitude of the function is gradually getting smaller and smaller. If the amplitude represented the distance that the swing was from the starting position, we would expect it to get smaller and smaller much more quickly than the above function. Let's find a more suitable model.

(b) Consider the function $y = e^{-0.5x} \sin(8x)$

- (i) Graph the function.
- (ii) What are the equations to the 'boundary' of the above function.
- (iii) Do you think this represents a better model of a swing?

A more detailed mathematical analysis of this topic can be found in many Physics and applied mathematics text books.

4.7 Post-test

- Change 36° to radians.
 - Change 0.14 radians into degrees.
 - Change $\frac{3\pi}{4}$ radians into degrees.
- Calculate the arc length of the sector shown below:

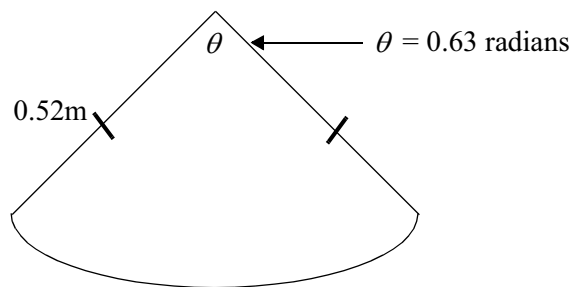

- Calculate the value of $\sin^2 20^\circ + \cos^2 20^\circ$.
 - For the function $y = 12 \cos\left(\frac{5x}{2}\right) + 3$, determine:
 - The amplitude of the function.
 - The period of the function.
 - The phase shift.
 - The vertical shift.
 - Solve the following equation in the domain $0 < x < 2\pi$:

$$\cos x = \frac{1}{2}$$

- Determine the period and the amplitude of the following function:

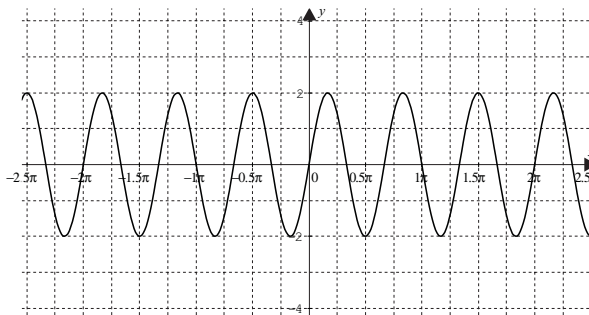

- Suggest an equation for the function shown in part (d).

4. The population of a colony of small rodents varies periodically, depending on the availability of food and the number of predators at any one time. Scientists have estimated that the population of the colony can be calculated by the formula:

$$P = 120 \sin\left(\frac{\pi t}{15}\right) + 20$$

Where P is the population of the colony and t the time in weeks since the colony was first observed.

- (a) Calculate the population of the colony 15 weeks after it was first observed.
- (b) When will the population reach 130?
- (c) What will be the maximum population of the colony?

4.8 Solutions

Solutions to activities

Activity 4.1

$$1. \text{ (a) } 35^\circ = \frac{35}{360} \times \frac{2\pi}{1} \\ \approx 0.61 \text{ radians}$$

$$\text{(b) } 98^\circ = \frac{98}{360} \times 2\pi \\ \approx 1.71 \text{ radians}$$

$$\text{(c) } 350^\circ = \frac{350}{360} \times 2\pi \\ \approx 6.11 \text{ radians}$$

$$\text{(d) } 120^\circ = \frac{120}{360} \times 2\pi \\ = \frac{1}{3} \times 2\pi \\ = \frac{2\pi}{3} \quad (\text{It is not uncommon to leave the answer in this form.}) \\ \approx 2.09 \text{ radians}$$

$$\text{(e) } 300^\circ = \frac{300}{360} \times 2\pi \\ = \frac{10\pi}{6} \\ \approx 5.24 \text{ radians}$$

Activity 4.2

$$1. \text{ (a) } 3.15 \text{ radians} = \frac{3.15}{2\pi} \times \frac{360}{1} \\ \approx 180.5^\circ$$

$$\text{(b) } \frac{3}{4}\pi \text{ radians} = \frac{3}{4} \times 180^\circ \quad (\text{Since } \pi \text{ radians is equivalent to } 180^\circ) \\ = 135^\circ$$

$$\text{(c) } \frac{5\pi}{6} \text{ radians} = \frac{5}{6} \times 180^\circ \\ = 150^\circ$$

2.

Degrees	Approximate value in radians	Exact value in radians (using π)
30	0.52	$\frac{\pi}{6}$
45	$\frac{\pi}{4} \approx \frac{3.142}{4} \approx 0.79$	$\frac{45}{360} \times 2\pi = \frac{1}{4} \times \pi = \frac{\pi}{4}$
60	1.05	$\frac{\pi}{3}$
90	1.57	$\frac{\pi}{2}$
180	3.14	π
270	4.71	$\frac{3\pi}{2}$
360	6.28	2π

Activity 4.3

1. (a) -0.924
 (b) 0.023
 (c) -7.70
 (d) 0.891 (Remember to change your calculator back to degree mode for this question.)

$$(e) \frac{\sin\left(\frac{\pi}{2} - 0.7\right)}{\cos 0.7} = \frac{0.765}{0.765} = 1$$

2. Left hand Side (LHS) = 1.7321

$$\begin{aligned} RHS &= \frac{4 \tan\left(\frac{\pi}{3}\right) - 4 \tan^3\left(\frac{\pi}{3}\right)}{1 - 6 \tan^2\left(\frac{\pi}{3}\right) + \tan^4\left(\frac{\pi}{3}\right)} \\ &\approx \frac{6.9282 - 20.7846}{1 - 18 + 9} \\ &\approx \frac{-13.8564}{-8} \\ &\approx 1.7321 \\ &= LHS \end{aligned}$$

$$\begin{aligned} \text{Note: } \tan^3\left(\frac{\pi}{3}\right) &= \left[\tan\left(\frac{\pi}{3}\right)\right]^3 \\ &= \tan\left(\frac{\pi}{3}\right) \times \tan\left(\frac{\pi}{3}\right) \times \tan\left(\frac{\pi}{3}\right) \end{aligned}$$

Activity 4.4

1. Use the given formula with $t = 5$ (as 2 p.m. is 5 hours after 9 a.m.)

$$\begin{aligned} T &= 10 + 8 \sin\left(\frac{\pi}{12}t\right) \\ &= 10 + 8 \sin\left(\frac{\pi}{12} \times 5\right) \\ &\approx 10 + 8 \sin(1.309) \\ &\approx 10 + 8 \times 0.966 \\ &\approx 10 + 7.73 \\ &\approx 17.73^\circ\text{C} \end{aligned}$$

2. (a) Use the formula with $t = 1$

$$\begin{aligned} V &= 240 \sin(100\pi t) \\ &= 240 \sin(100\pi \times 1) \\ &\approx 240 \sin(314.2) \\ &= 240 \times 0 \\ &= 0 \text{ volts} \end{aligned}$$

(b) This time use $t = 1.005$

$$\begin{aligned} V &= 240 \sin(100\pi t) \\ &= 240 \sin(100\pi \times 1.005) \\ &\approx 240 \sin(315.73) \\ &= 240 \times 1 \\ &= 240 \text{ volts} \end{aligned}$$

3. Since the circumference of the child's head is 45 cm, the length of the arc must also be 45 cm. As we already know the radius we can calculate the angle, thus:

$$\begin{aligned} \text{length of arc} &= r\theta \\ 45 &= 80 \times \theta \\ \frac{45}{80} &= \theta \\ \theta &= 0.5625 \text{ radians} \\ &\approx 32.2^\circ \end{aligned}$$

4. It is convenient to firstly convert the angle to radians,

$$\begin{aligned} \theta &= 35^\circ \\ &= \frac{35}{360} \times 2\pi \\ &\approx 0.61 \text{ radians} \end{aligned}$$

We can now use the following relationship to find the size of the radius,

$$\begin{aligned} \text{arc length} &= r\theta \\ 12 &= r \times 0.61 \\ r &= \frac{12}{0.61} \\ &\approx 19.64 \text{ cm} \end{aligned}$$

5. A diagram to commence with may help.

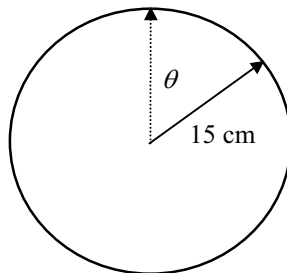

Since the hand moves 360° every 60 seconds, then it should move 6° each second. So in 14 seconds the angle swept out by the hand will be:

$$\begin{aligned}\theta &= 14 \times 6^\circ \\ &= 84^\circ \\ &\approx 1.47 \text{ radians}\end{aligned}$$

Therefore the distance travelled by the tip of the hand is:

$$\begin{aligned}\text{length of arc} &= r\theta \\ &= 15 \times 1.47 \\ &\approx 22 \text{ cm}\end{aligned}$$

6. The student had originally had his calculator in degree mode whereas it should have been in radian mode. (It is a good idea to have the calculator in radian mode all the time except when dealing with problems involving triangles.)
7. If we consider the area of the full circle first then,

$$\begin{aligned}\text{Area of full circle} &= \pi r^2 \\ &= \pi \times 3^2 \\ &\approx 28.27\end{aligned}$$

$$\begin{aligned}\text{Area of window} &= \frac{25^\circ}{360^\circ} \times 28.27 \\ &\approx 1.96 \text{ m}^2\end{aligned}$$

8. Suppose the angle at the centre of the sector is θ radians, then we can derive the formula in much the same way that we did question 7, namely:

$$\begin{aligned}\text{Area of full circle} &= \pi r^2 \\ \text{so area of sector} &= \frac{\theta}{2\pi} \times \pi r^2 \quad (\text{Since the total angle in a circle is } 2\pi \text{ radians.}) \\ &= \frac{1}{2} \theta r^2\end{aligned}$$

9. (a) We need to substitute the value $t = 5$ into the given formula, making sure that the calculator is set on radians.

$$\begin{aligned}h &= 0.8 \cos \frac{1}{6} \pi t + 6.5 \\ &= 0.8 \cos \left(\frac{1}{6} \times \pi \times 5 \right) + 6.5 \\ &\approx 0.8 \times -0.866 + 6.5 \\ &\approx 5.8 \text{ m}\end{aligned}$$

(b) In this question we need to substitute the value of $h = 2$ into the given formula.

$$\begin{aligned}
 h &= 0.8 \cos \frac{1}{6} \pi t + 6.5 \\
 2 &= 0.8 \cos \frac{1}{6} \pi t + 6.5 \\
 -4.5 &= 0.8 \cos \frac{1}{6} \pi t \\
 -5.625 &= \cos \frac{1}{6} \pi t \\
 \frac{1}{6} \pi t &= \cos^{-1}(-5.625) \text{ which does not exist.}
 \end{aligned}$$

Therefore the tide is never at a height of 2 m in the harbour entrance, it will always range from 5.7 m to 7.3 m. (Do you know how I worked this out? Hopefully you will be able to by the end of this unit.)

Activity 4.5

1. The graph of $y = \sin 3x$ is shown below:

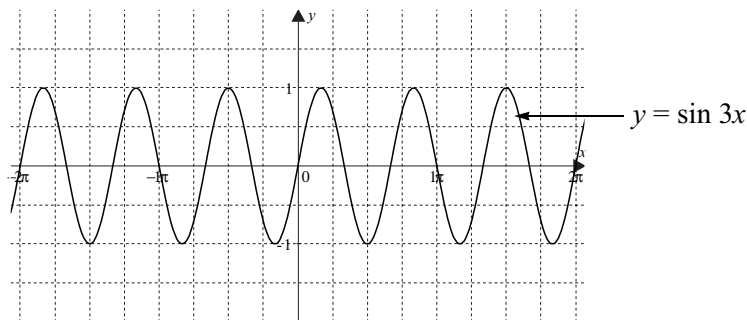

2. In order to write meaningful sentences it is necessary to firstly draw the two functions on the same graph:

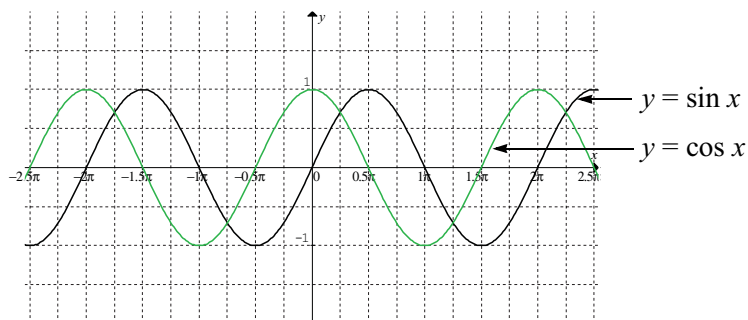

Your paragraph should contain the following:

- The graphs of $y = \sin x$ and $y = \cos x$ are very similar.
 - The amplitude and period of both graphs are the same (amplitude = 1; period = 2π).
 - The shapes of both graphs are the same.
 - The graph of the function $y = \sin x$ is the same as if we took the graph of $y = \cos x$ and moved it to the right a distance of $\frac{\pi}{2}$ radians. This horizontal distance separating the two functions is sometimes known as the phase shift.
 - The y -intercept of $y = \sin x$ is $y = 0$ and the y -intercept of $y = \cos x$ is $y = 1$.
3. The graph of $y = \tan x$ is shown below:

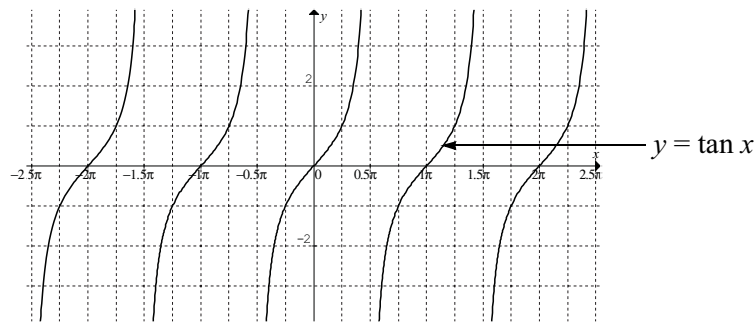

The curve is periodic, however it is also discontinuous at $x = -1.5\pi, -0.5\pi, 0.5\pi, 1.5\pi$ etc.

4. (a) The two graphs are shown below:

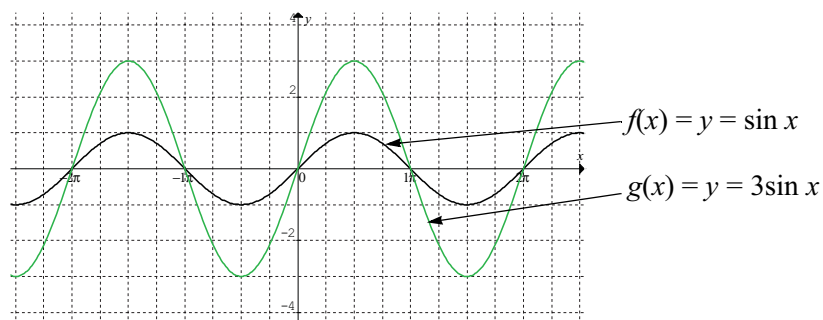

- (b) We see that the function $g(x) = 3\sin x$ will move a lot further from the x -axis than the function $f(x) = \sin x$. In other words the amplitude of $g(x)$ is 3 times the amplitude of $f(x)$.

Activity 4.6

1. $a = 3, b = 2, c = 1$ and $d = 4$
2. $a = 5, b = 2, c = -2$ and $d = -12$
3. It might help if we first rewrite the equation as $y = -1\sin\left(\frac{1}{3}x + 0\right) + 2.5$ then the values are easy to determine, i.e. $a = -1, b = \frac{1}{3}, c = 0$ and $d = 2.5$.
4. In this equation the variable y is replaced by V and the variable x by t . The values of the parameters are $a = 12, b = 20\pi, c = -0.5$ and $d = 0$.
5. Firstly rewrite the equation as $D = -1\cos(-2t + 3) + 25$. The variable y is replaced by D and the variable x is replaced by t . The values of the parameters are $a = -1, b = -2, c = 3$ and $d = 25$.

Activity 4.7

1. The amplitude in each case is the value of the parameter ' a '.
 - (a) $|a| = 3$
 - (b) $|a| = 3$
 - (c) $|a| = 0.5$
2. The amplitude is one half the vertical distance between the highest part of the curve and the lowest part of the curve.
 - (a) From the graph we see the highest part of the curve occurs at $y = 3$ and the lowest part at $y = -3$. The vertical distance between these is 6 units and therefore the amplitude is $6 \div 2 = 3$.
 - (b) From the graph we see the highest part of the curve occurs at $y = 2$ and the lowest part at $y = 0$. The vertical distance between these is 2 units and therefore the amplitude is 1.

Activity 4.8

1. The vertical shift in each case is the value of the parameter d .
 - (a) $d = -2$
 - (b) $d = 12$
2. Normally the x -axis divides a sinusoidal curve such as this, exactly in half lengthways. We see from the graph that now the line $y = 3$ divides the curve in half, consequently the vertical shift is 3 units, that is all points on the curve $y = \sin x$ have been moved up 3 units.
3. The highest part of the curve occurs at $y = 5$ and the lowest at $y = 1$. The vertical distance separating these two points is 4 units, consequently the amplitude is one half this distance, i.e. 2.

Activity 4.9

1. The value of the parameter b in this case is π . Therefore

$$\begin{aligned} \text{period} &= \left| \frac{2\pi}{b} \right| \\ &= \frac{2\pi}{\pi} \\ &= 2 \end{aligned}$$

2. (a) See below for the graph of $y = \cos x$

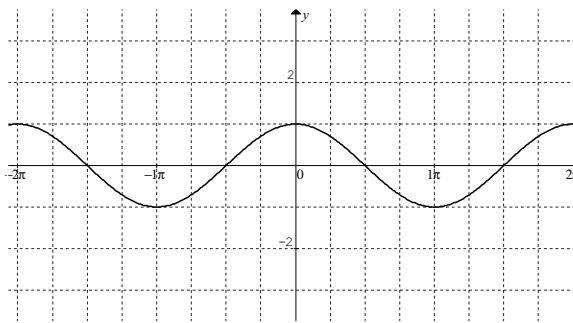

$$\text{Period} = 2\pi$$

- (b) See below for the graph of $y = \cos 2x$

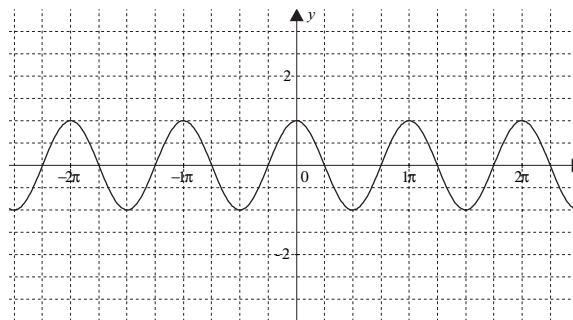

$$\text{Period} = \pi$$

- (c) From an inspection of the two graphs it is apparent that the period of $y = \cos 2x$ is one half that of $y = \cos x$, i.e. $\frac{2\pi}{2} = \pi$. Therefore the period of the cosine function

$$y = \cos bx \text{ is given by the expression } \frac{2\pi}{b}.$$

3. (a) The graph of the function $y = \tan x$ is shown below.

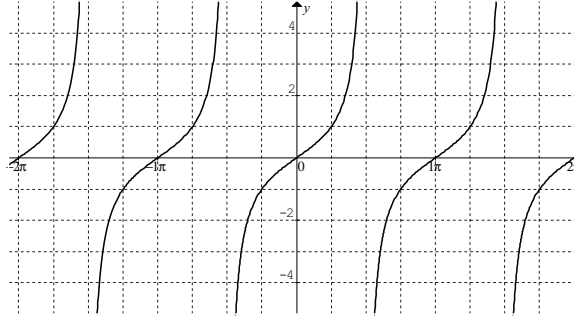

Period = π

(b) The graph of $y = \tan 2x$ is shown below.

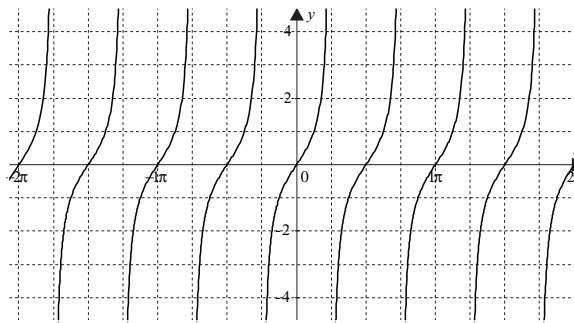

Period = $\frac{\pi}{2}$

(c) After we analyse both of the above graphs we see that the period of $y = \tan 2x$ is half of the period of $y = \tan x$, i.e. $\frac{\pi}{2}$. Therefore in general the period of $y = \tan bx$ would be

given by the expression $\left| \frac{\pi}{b} \right|$.

4. (a) The graphs of the two functions are shown below.

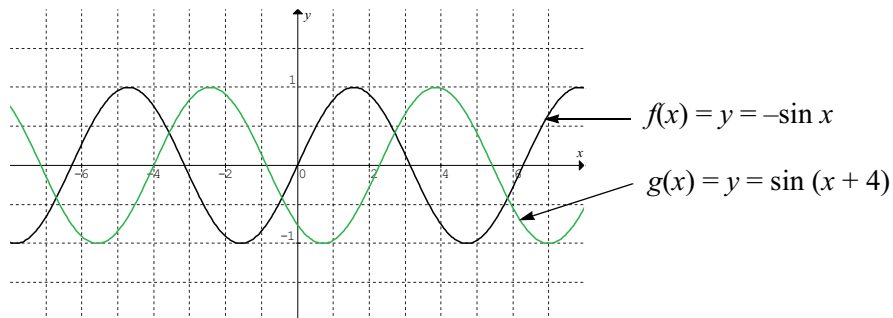

(b) The period of $g(x)$ is 2π

(c) As can be seen from the graphs, the function $g(x)$ has the same basic shape as $f(x)$ except it has shifted 4 units to the left.

5. (a) Firstly determine the value of the parameter b . In this case it is 1. Therefore

$$\begin{aligned}\text{period} &= \left| \frac{2\pi}{b} \right| \\ &= \frac{2\pi}{1} \\ &= 2\pi\end{aligned}$$

(b) In this case $b = 2\pi$, therefore:

$$\begin{aligned}\text{period} &= \left| \frac{2\pi}{b} \right| \\ &= \frac{2\pi}{2\pi} \\ &= 1\end{aligned}$$

(c) In this case $b = \frac{5}{3}$, however the relationship for calculating the period of a tangent function is:

$$\begin{aligned}\text{period} &= \left| \frac{\pi}{b} \right| \\ &= \frac{\pi}{5/3} \\ &= \frac{3\pi}{5}\end{aligned}$$

6. (a) From the graph the period is π .

(b) This one is not so obvious. It is best to measure the distance between successive peaks of the function. If this is done, we find that the period is approximately 4.2.

Activity 4.10

1. (i) In this function $b = 1$ and $c = 2$, therefore the phase shift is 2. The shift is 2 units to the left in comparison to the function $y = -\cos x$

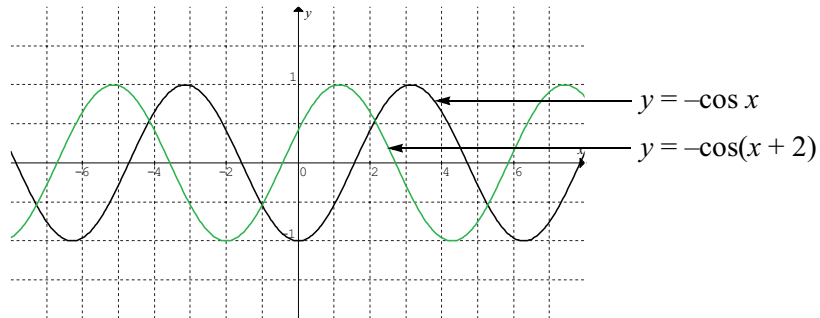

- (ii) In this function $b = 3$ and $c = 2$, therefore phase shift $= \frac{c}{b} = \frac{2}{3}$. The shift is to the left in comparison to the function $y = 12\sin 3x$.

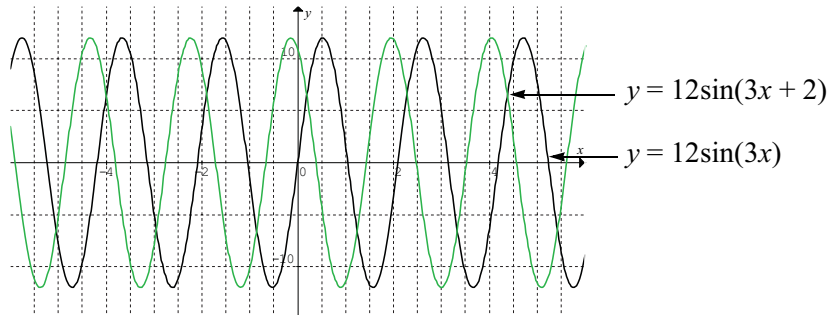

- (iii) Rewrite the function in the form $y = a \cos(bx + c) + d$:

$$h = -1 \cos\left(\frac{1}{5}t + \frac{4}{5}\right) + 12$$

Therefore $b = \frac{1}{5}$ and $c = \frac{4}{5}$ and the phase shift $= \frac{c}{b} = 4$. The shift is 4 units to the left in comparison to $h = 12 - \cos\left(\frac{t}{5}\right)$.

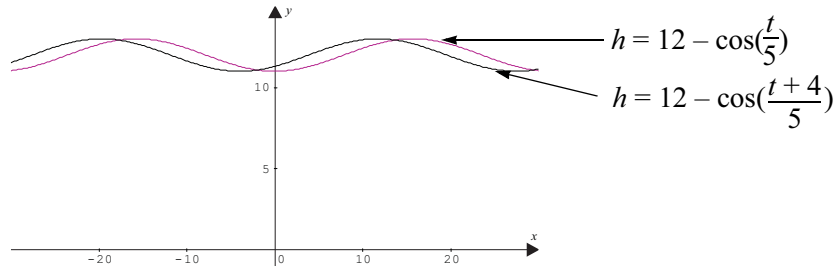

(iv) Rewrite the function in the form $y = a \sin(bx + c) + d$:

$$y = \sin\left(-1x + \frac{\pi}{2}\right)$$

Therefore $b = -1$ and $c = \frac{\pi}{2}$ and the phase shift $= \frac{c}{b} = -\frac{\pi}{2}$. The shift is $-\frac{\pi}{2}$ to the right in comparison to the function $y = \sin(-x)$.

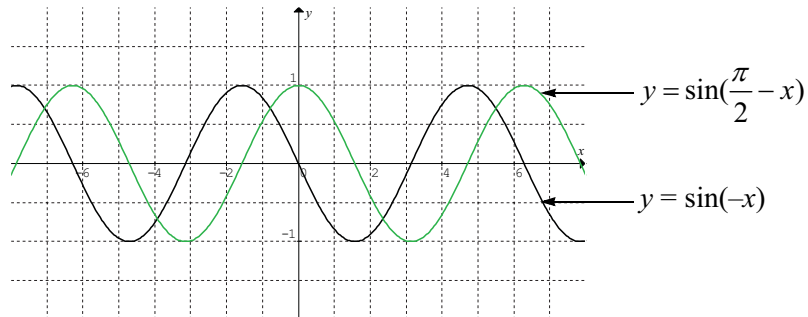

2. (a) The graph(s) are shown below:

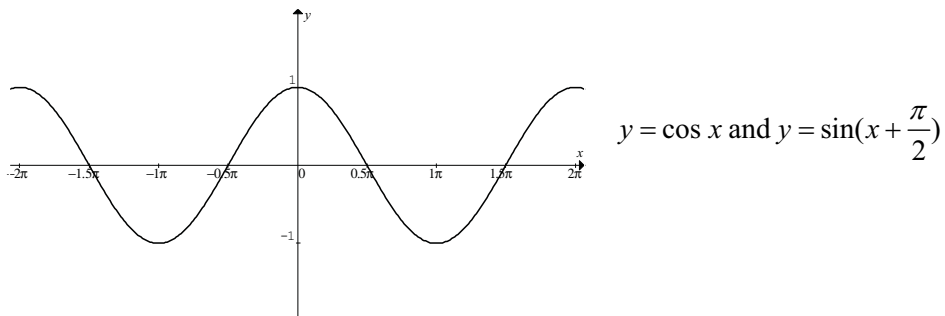

- (b) When you graphed the two graphs only one appeared. This is because the two functions $y = \cos x$ and $y = \sin(x + \frac{\pi}{2})$ are identical functions. The graph of the cosine function $y = \cos x$ can be formed if we take the graph of the function $y = \sin x$ and move it a distance of $\frac{\pi}{2}$ units to the left, i.e. $y = \sin(x + \frac{\pi}{2})$. (You could say that the cosine function is the cousin of the sine function). For this reason rules which apply to the sine function, apply equally to the cosine function.

Activity 4.11

1. $a = 1.5$;

$$\text{period} = 4 \text{ so } b = \frac{2\pi}{4} = \frac{\pi}{2}$$

$$\text{phase is } 0.25 \text{ so } c = -0.25 \times \frac{\pi}{2} = -0.125\pi$$

$$\text{equation: } y = 1.5 \sin(0.5\pi t - 0.125\pi)$$

2. Amplitude $a = 1.5$;

$$\text{Period} = 4\pi \text{ so } b = \frac{2\pi}{4\pi} = 0.5$$

$$\text{Phase shift is } 0.5\pi \text{ to the right so } c = -0.5\pi \times 0.5 = -0.25\pi$$

$$\text{The equation is } y = 1.5 \cos(0.5t - 0.25\pi).$$

(You could have also written $y = 1.5 \cos(0.5t + 1.75\pi)$ if you said the phase shift was 3.5π to the left.)

Activity 4.12

1. Your result should be similar to 2(a) below.
2. (a) The graph of $y = \tan^{-1} x$ is shown below using Graphmatica:

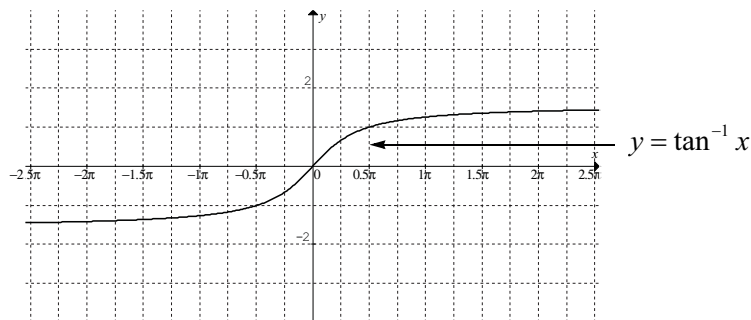

Note: Graphmatica uses the notation 'atan(x)' to represent $\tan^{-1} x$.

(b) (i) Using Graphmatica's point menu we find that when $x = 1.2$, $y \approx 0.88$.

(ii) When $x = 4$, $y \approx 1.33$

(c) When $x = 167$, y would be very close to $\frac{\pi}{2}$ (using the point menu it is 1.56)

3.

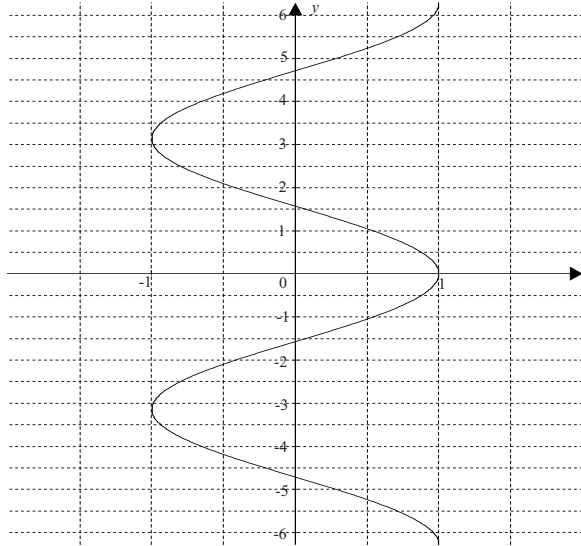

Activity 4.13

1. (a)

$$\sin x = \frac{1}{2}$$

$$x = \sin^{-1} \frac{1}{2}$$

$$x \approx 0.52 \text{ or } \pi - 0.52$$

$$\approx 0.52 \text{ or } 2.62$$

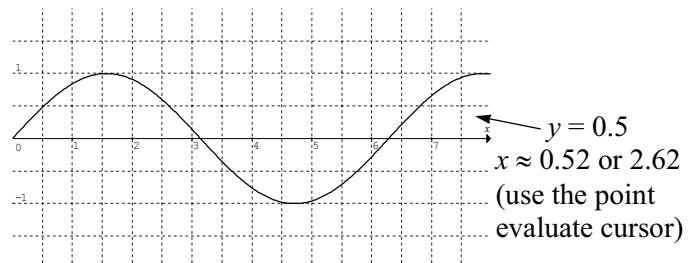

(b) $\cos x = 0.72$

$$x = \cos^{-1} 0.72$$

$$\approx 0.77 \text{ or } 2\pi - 0.77$$

$$\approx 0.77 \text{ or } 5.52$$

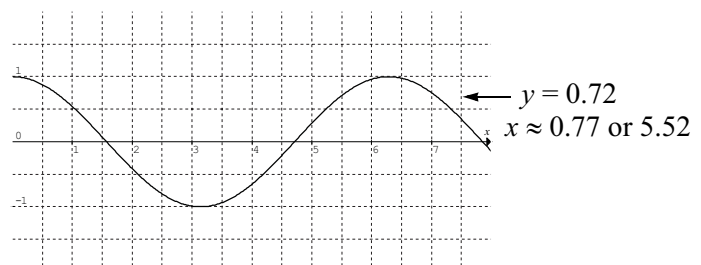

(c) $\sqrt{2} \cos x - 1 = 0$

$$\cos x = \frac{1}{\sqrt{2}}$$

$$x = \cos^{-1} \frac{1}{\sqrt{2}}$$

$$\approx 0.79 \text{ or } 2\pi - 0.79$$

$$= 0.79 \text{ or } 5.50$$

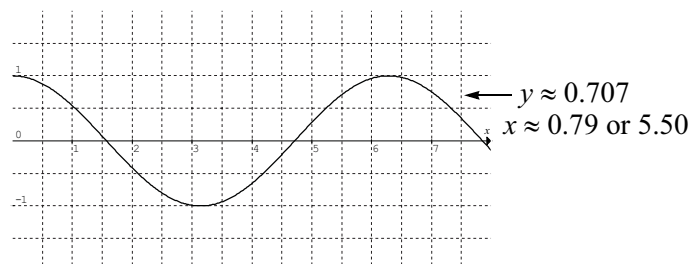

To solve graphically you can draw a graph of $y = \cos x$ and $y = \frac{1}{\sqrt{2}}$ (as in the diagram)

or you could graph $y = \sqrt{2} \cos x$ and $y = 1$.

2. If we find the period of the function in question we find that it is:

$$\begin{aligned} \text{period} &= \frac{2\pi}{b} \\ &= \frac{2\pi}{\pi/12} \\ &= 24 \text{ hours} \end{aligned}$$

So we need to determine when the temperature is 15°C in one period of the function. One possible method would be to draw a graph and read the answers from the graph (see below):

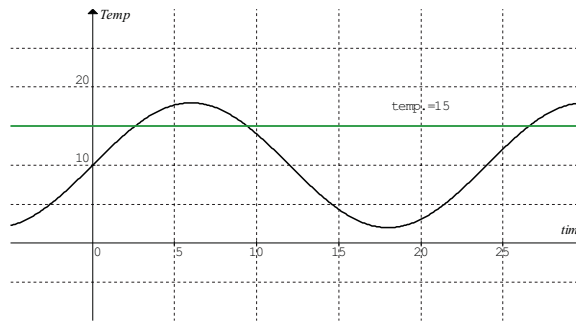

We see from the graph that the temperature is 15°C twice in the first 24 hours, that is when $t \approx 2.5$ h and 9.5 h. Since t is the time after 9 a.m., then these times represent 11:30 a.m. and 6:30 p.m. respectively.

It is sometimes more convenient to formulate an equation and solve it algebraically. In this case $T = 15$ and we need to determine t .

$$15 = 10 + 8 \sin\left(\frac{\pi}{12}t\right)$$

$$5 = 8 \sin\left(\frac{\pi}{12}t\right)$$

$$\frac{5}{8} = \sin\left(\frac{\pi}{12}t\right)$$

$$\frac{\pi}{12}t = \sin^{-1} \frac{5}{8}$$

$$\frac{\pi}{12}t \approx 0.675 \text{ or } \pi - 0.675$$

$$\frac{\pi}{12}t \approx 0.675 \text{ or } 2.47$$

$$t \approx 0.675 \times \frac{12}{\pi} \text{ or } 2.47 \times \frac{12}{\pi}$$

$$\approx 2.58 \text{ or } 9.42$$

Our results are more accurate this time with times of 11:35 a.m. and 6:25 p.m.

3. In this case we know the values of the variables V , d and t , namely:

$$V = 200 \text{ m/s}, \quad d = 2000 \text{ m}, \quad t = 20 \text{ s}$$

We need to substitute these into the given formula and solve it algebraically:

$$d = (V \cos \theta)t$$

$$2000 = (200 \times \cos \theta) \times 20$$

$$2000 = 4000 \times \cos \theta$$

$$\cos \theta = 0.5$$

$$\theta = \cos^{-1} 0.5$$

$$\approx 1.05 \text{ radians}$$

$$= 60^\circ$$

Hence the projectile needs to be launched at an angle of 60° to the horizontal if it is to strike the target in 20 seconds.

4. (a) $\cos^2 0.71 + \sin^2 0.71 \approx 0.76^2 + 0.65^2$
 $\approx 0.58 + 0.42$
 $= 1$

(b) The answer should be again 1.

5. (a) To graph these functions using Graphmatica you need to use the following formulae:

$$y = (\sin(x))^2 \text{ and } y = (\cos(x))^2 \text{ for } f(x) \text{ and } g(x) \text{ respectively.}$$

The two functions $f(x)$ and $g(x)$ are shown below:

4.70 TPP7183 – Mathematics tertiary preparation level C

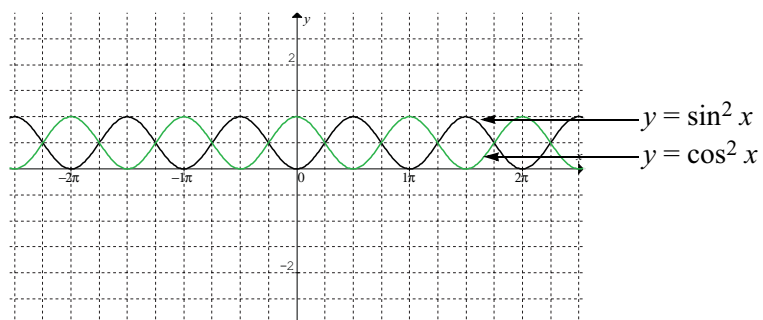

- (b) The graph of $y = \sin^2 x + \cos^2 x$ is a straight line parallel to the x -axis and passing through $y = 1$.

Activity 4.14

1. (a) Algebraically, the solution to the equation could be done as follows:

$$\sin x = \tan x$$

$$\sin x = \frac{\sin x}{\cos x}$$

$$\sin x \times \cos x = \sin x$$

$$\sin x \times \cos x - \sin x = 0$$

$$\sin x(\cos x - 1) = 0$$

Equating each factor of the product to 0 gives:

$$\sin x = 0$$

$$x = \sin^{-1} 0$$

$$= 0, \pi \text{ or } 2\pi$$

and

$$\cos x - 1 = 0$$

$$\cos x = 1$$

$$x = \cos^{-1} 1$$

$$= 0 \text{ or } 2\pi$$

That is the solutions are $x = 0, \pi$ and 2π .

To solve the equation graphically the two functions $f(x) = y = \sin x$ and $g(x) = y = \tan x$ need to be drawn on the same graph (see below):

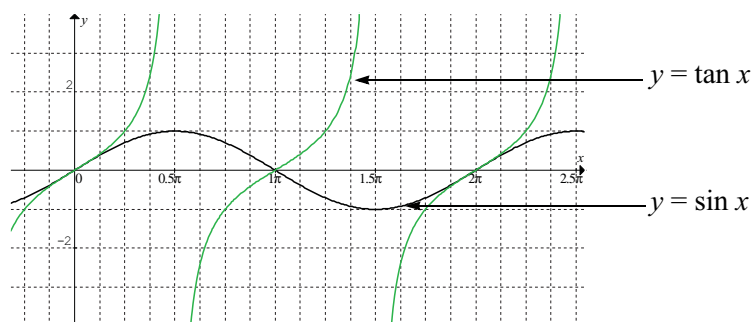

Notice the points of intersection occur at $x = 0, \pi$ and 2π .

- (b) It is far easier to solve this using graphical methods, i.e. follow the hint and graph $y = \sin x$ and $y = 1 - \cos x$ (see below):

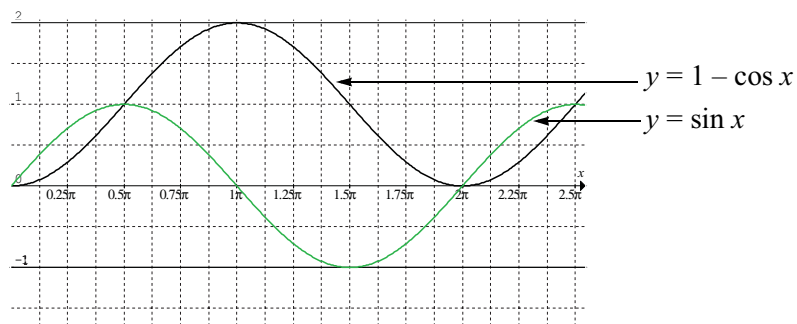

From observing the graphs we see that intersection points occur at $x = 0$, $\frac{\pi}{2}$, and 2π .

Algebraically we can solve the equation:

$$\begin{aligned} \sin x &= 1 - \cos x \\ \sin^2 x &= (1 - \cos x)^2 \\ 1 - \cos^2 x &= 1 - 2\cos x + \cos^2 x \\ \text{Let } y &= \cos x \\ 1 - y^2 &= 1 - 2y + y^2 \\ 0 &= 2y^2 - 2y \\ 0 &= y^2 - y \\ &= y(y - 1) \\ \therefore y &= 0 \text{ or } 1 \\ \therefore \cos x &= 0 \\ x &= \frac{\pi}{2} \text{ or } \frac{3\pi}{2} \\ \text{or } \cos x - 1 &= 0 \\ x &= 0 \text{ or } 2\pi \end{aligned}$$

From the graph, or substituting into the equation only some of these solutions are true.

So $x = \frac{\pi}{2}$, 0 or 2π

2. Graph the equations $y = \sin 2x$ and $y = 4 - 2x$. If you quickly sketch it first, you should see it will cut in the 1st or 4th quadrant and before $x = 4$. So set the domain between 0 and 4. Now using Graphmatica, you can see the point will be about 2.48.

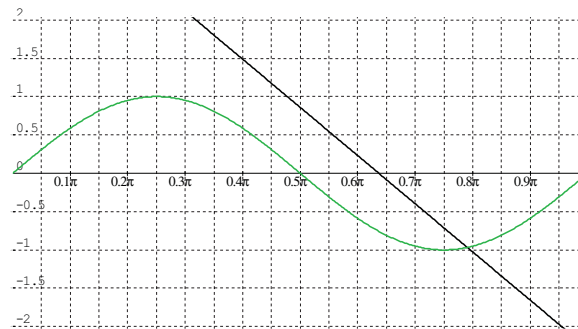
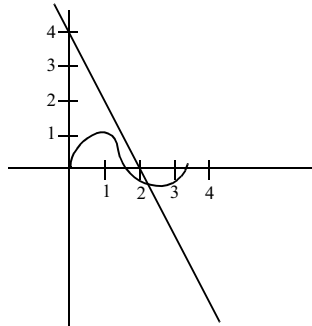

(Checking this answer in the original equation we get $\sin(2 \times 2.48) + 2 \times 2.48 \approx 4$.)

3. You've done a great job so far. You have correctly solved the equation. There are no real solutions to this equation. If you graph the equation $y = \sin 2x$ and $y = 5 - \cos 2x$, you would find they never touched or crossed.
4. In order to do this question we need to graph $f(x) = y = \sin x$ and $g(x) = y = M - \cos x$ as in the question above, except we do not know what value M is to take. I used a bit of guess and check for this question and found if I substituted $M = 1.5$, the two graphs were not touching, so therefore there would be no solution if $M = 1.5$ (see the graph below).

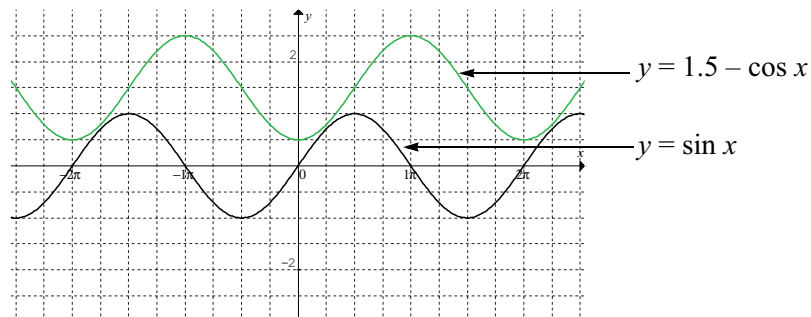

However you will notice from the graph that the closest point is at $x = \frac{\pi}{4}$ and the two graphs could in fact be a bit closer together without touching. Let's work out the height separating the two functions:

$$\text{when } x = \frac{\pi}{4}$$

$$f(x) = \sin \frac{\pi}{4} \\ \approx 0.71$$

$$\text{and } g(x) = 1.5 - \cos \frac{\pi}{4} \\ \approx 0.79$$

Consequently there is a vertical distance of $0.79 - 0.71 = 0.08$ and the two graphs: $f(x) = \sin x$ and $g(x) = (1.5 - 0.08) - \cos x$ will touch each other (try it and see). That is $M \approx 1.42$.

If we are more careful with decimal places we obtain a value of $M \approx 1.414$ which some of you may recognise to be $\sqrt{2}$. Therefore the maximum value that M can take in order that the equation has a solution is $\sqrt{2}$.

We can do this algebraically as well. **The following is for your interest only. (You do not have to learn this.)**

$$\begin{aligned} \sin x &= M - \cos x \\ \sin^2 x &= (M - \cos x)^2 \\ 1 - \cos^2 x &= M^2 - 2M \cos x + \cos^2 x \\ 0 &= M^2 - 1 - 2M \cos x + 2 \cos^2 x \\ 0 &= 2 \cos^2 x - 2M \cos x + (M^2 - 1) \end{aligned}$$

This is in the pattern of

$$ax^2 + bx + c = 0 \text{ where } a = 2; b = -2M \text{ and } c = M^2 - 1$$

Using the formula to find $\cos x$ we get:

$$\cos x = \frac{2M \pm \sqrt{4M^2 - 4 \times 2 \times (M^2 - 1)}}{4}$$

If this is to have any real solutions the discriminant must be equal to or greater than zero.
So solving the equality:

$$0 = 4M^2 - 8M^2 + 8$$

$$0 = -4M^2 + 8$$

$$M^2 = 2$$

$$M = \pm\sqrt{2}$$

So the maximum value of M is $\sqrt{2}$.

Solutions to a taste of things to come

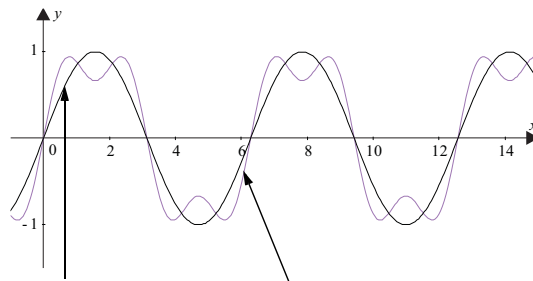

1. (a) Graph of (i) $y = \sin x$ and (ii) $y = \sin x + \frac{1}{3}\sin(3x)$

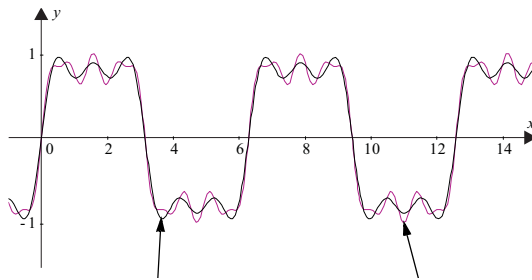

- Graphs of (iii) $y = \sin x + \frac{1}{3}\sin 3x + \frac{1}{5}\sin 5x$ and (iv) $y = \sin x + \frac{1}{3}\sin 3x + \frac{1}{5}\sin 5x + \frac{1}{9}\sin 9x$

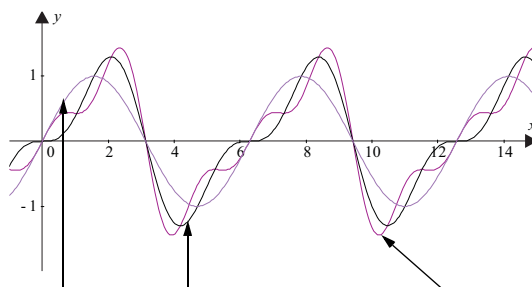

- (b) Graphs of (i) $y = \sin x$, (ii) $y = \sin x - \frac{1}{2}\sin 2x$ and (iii) $y = \sin x - \frac{1}{2}\sin 2x + \frac{1}{3}\sin 3x$

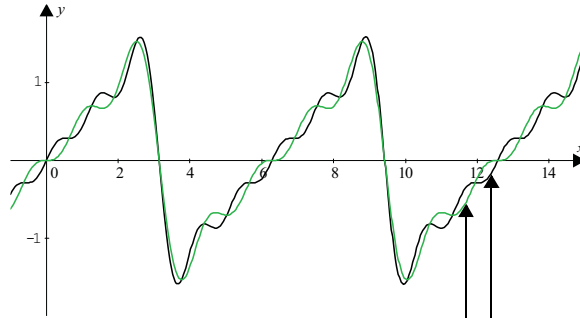

Graphs of (iv) $y = \sin x - \frac{1}{2} \sin 2x + \frac{1}{3} \sin 3x - \frac{1}{4} \sin 4x$

and (v) $y = \sin x - \frac{1}{2} \sin 2x + \frac{1}{3} \sin 3x - \frac{1}{4} \sin 4x + \frac{1}{5} \sin 5x$

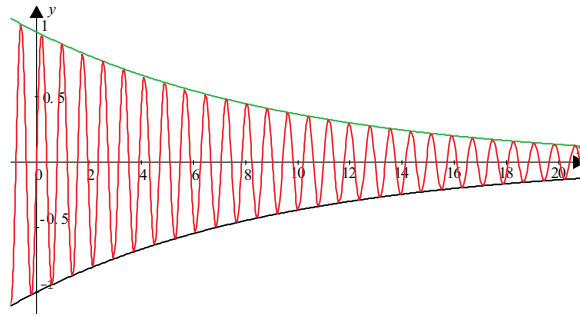

2. (a) (i) and (ii) The graph above is the function $y = e^{-0.1x} \sin(8x)$ and bounded by the functions, $y = e^{-0.1x}$ and $y = -e^{-0.1x}$.

- (iii) The swing was pushed so it went 1 metre from the starting position. The swing swung back and forwards, gradually decreasing in distance. After 20 seconds it was still swinging 0.14 of a metre.

- (b) (i)

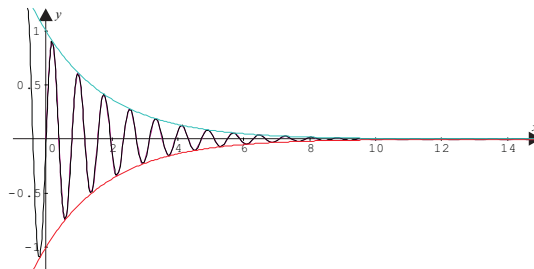

- (ii) Graph of $y = e^{-0.5x} \sin 8x$ bounded by $y = e^{-0.5x}$ and $y = -e^{-0.5x}$

- (iii) This is a better model since the distance gets smaller much quicker. If the swing was pushed harder then the maximum distance from the starting position would be larger, so the formula could be $y = 2e^{-0.5x} \sin 8x$.

Solutions to post-test

1. (a) $180^\circ = \pi$ radians

$$1^\circ = \frac{\pi}{180} \text{ radians}$$

$$\begin{aligned} 36^\circ &= 36 \times \frac{\pi}{180} \text{ radians} \\ &= 0.63 \text{ radians} \end{aligned}$$

(b) π radians = 180°

$$1 \text{ radians} = \frac{180^\circ}{\pi}$$

$$\begin{aligned} 0.14 \text{ radians} &= 0.14 \times \frac{180^\circ}{\pi} \\ &= 8.02^\circ \end{aligned}$$

(c) $\frac{3\pi}{4}$ radians = $\frac{3 \times 180^\circ}{4}$
= 135°

2. arc length = θr

$$= 0.63 \times 0.52$$

$$= 0.3276 \text{ m}$$

3. (a) The value will be 1, as you have learnt that $\sin^2 \theta + \cos^2 \theta = 1$ for all values of θ .

(b) Write the function in the general form $y = a \cos(bx + c) + d$.

So in this case: $y = 12 \cos\left(\frac{5}{2}x + 0\right) + 3$

(i) The amplitude $a = 12$.

(ii) period = $\frac{2\pi}{b}$
= $\frac{2\pi}{5/2}$
= $\frac{4\pi}{5}$

(iii) The phase shift $= \frac{c}{b} = \frac{0}{\frac{5}{2}} = 0$.

(iv) The vertical shift $d = 3$.

(c) $\cos x = \frac{1}{2}$

$$x = \cos^{-1} \frac{1}{2}$$

$$= \frac{\pi}{3} \text{ or } (2\pi - \frac{\pi}{3}) \quad \text{Since } \cos x \text{ is positive in the 1st and 4th quadrants}$$

$$= \frac{\pi}{3} \text{ or } \frac{5\pi}{3}$$

$$\approx 1.05 \text{ or } 5.24$$

(d) From the graph the amplitude is 2 units. Also from the graph we see that there are three cycles of the function every 2π units, therefore the period is $\frac{2\pi}{3}$ units.

(e) Since the curve shown has a y -intercept of zero, it can be modelled more easily by a sine function. Therefore we use the general equation of a sine function, i.e. $y = a \sin(bx + c) + d$. The function shown has no vertical shift or phase shift, so $c = 0$ and $d = 0$. Since the amplitude is 2, then $a = 2$. So we only need to work out the value of b .

$$\text{period} = \frac{2\pi}{b}$$

$$\frac{2\pi}{3} = \frac{2\pi}{b} \quad (\text{using the result from part b})$$

$$b = 3$$

Therefore the equation of the function shown is found if we substitute the values obtained for a , b , c and d into the general equation $y = a \sin(bx + c) + d$.

In this case the result is $y = 2 \sin 3x$.

4. (a) We need to substitute $t = 15$ into the given equation.

$$\begin{aligned} P &= 120 \sin\left(\frac{\pi t}{15}\right) + 20 \\ &= 120 \sin\left(\frac{\pi \times 15}{15}\right) + 20 \\ &= 120 \sin \pi + 20 \\ &= 120 \times 0 + 20 \\ &= 20 \end{aligned}$$

(b) We need to substitute $P = 130$ into the given equation and then solve the equation.

$$\begin{aligned}
 P &= 120 \sin\left(\frac{\pi t}{15}\right) + 20 \\
 130 &= 120 \sin\left(\frac{\pi t}{15}\right) + 20 \\
 110 &= 120 \sin\left(\frac{\pi t}{15}\right) \\
 \frac{110}{120} &= \sin\left(\frac{\pi t}{15}\right) \\
 \sin\left(\frac{\pi t}{15}\right) &\approx 0.917 \\
 \frac{\pi t}{15} &= \sin^{-1} 0.917 \\
 &\approx 1.16 \text{ or } \pi - 1.16 \\
 &= 1.16 \text{ or } 1.98 \\
 t &= \frac{15}{\pi} \times 1.16 \text{ or } \frac{15}{\pi} \times 1.98 \\
 &\approx 5.54 \text{ or } 9.45
 \end{aligned}$$

Therefore the population will be 130 after approximately 5.5 weeks and 9.5 weeks. It will also reach this level every 30 weeks (the period of the function) after these two times.

(c) The amplitude of the function is 140 and the vertical shift is 20, so the maximum value of the function will be 140. You will get this result if you draw the graph using Graphmatica.

