

# Module C5

Analytical geometry –  
representing points and  
curves

---



## Introduction

Do you often ride in taxis? Even if you don't I'm sure you have respect for the drivers who are able to drive around the city with ease getting you to your destination by the quickest route (there must be some who do this!). Taxi drivers should appreciate this module! John Paulos, in his book *Beyond Numeracy* alluded to this connection between analytical geometry and taxi drivers thus:

*As is the case with many fundamental discoveries, the insight that led to analytical geometry is in retrospect very simple and obvious to all, and to cabdrivers in particular. In taxi terms this insight can be phrased: Every intersection corresponds to a street and an avenue, and every street and avenue corresponds to an intersection. A more mathematical rendering states that every point corresponds to an ordered pair of numbers, and every ordered pair of numbers corresponds to a point. (p. 10)*

So far in this course, you have studied families of functions. In this module we will look at mathematics from a different perspective – a geometrical one. Geometry has a very important role in the history of mathematics. Ancient Greek mathematicians were well advanced in mathematical thinking, but they lacked the algebraic tools to develop mathematics, so relied on geometry to solve problems and develop concepts. These concepts we still use today. It was not until the 17th Century that mathematicians Pierre Fermat (who was a lawyer as well) and Rene Descartes (who was a philosopher as well) made a breakthrough that seems so logical to us today. They attached numbers to geometrical objects. They did this through the coordinate system. We know this today as the Cartesian coordinate system and you have used this system in your studies so far. But there are other systems which can be used more effectively in different circumstances.

We will now look at different systems for describing points and curves. In this module, as in previous modules, we will be using Graphmatica to develop concepts, but again it is important for you to be able to *see* what the figures will be like before using Graphmatica. To do this you need a thorough understanding of the relationship between the parameters in an equation and their shapes; this module will help develop these skills.

In particular, on completion of this module you should be able to:

- identify points using rectangular coordinates, polar coordinates, and vectors
- change from polar to rectangular coordinates and vice-versa
- demonstrate an understanding of a vector
- express vectors in terms of a column matrix, and  $i$  and  $j$
- identify characteristics of straight lines and segments including equations, length and mid-point
- identify characteristics of standard curves (polynomial, exponential, logarithmic, circular, and hyperbolas)
- examine transformations of linear, parabolic, exponential, logarithmic, circular curves and rectangular hyperbolas
- examine other curves and investigate the importance of parameters in their equations.

## 5.1 Describing points in space

Did you ever see the movie *Stargate*? In the movie, the code to unlock the Stargate was broken by understanding how to position a point in space. There are a number of ways to do this. To position a point in space we need some reference surface and a method that refers to it. There are a number of ways to position points in space. We will only investigate some of these and only look at 2 dimensions. In this section, we will revisit the rectangular coordinate system (The Cartesian Plane), look at the polar coordinate system and take a brief look at vectors. There are other systems of coordinates around including three dimensional systems, and you may come across them, especially if you study surveying (e.g. latitude and longitude system, the World Geodetic System or the Global Positioning System).

### 5.1.1 Rectangular coordinates

Suppose we are in a city and we call a taxi. The taxi driver may have to resort to a street directory to locate our street in relation to the current position. The driver might say I have to go 4 streets east then 2 streets north to get to our location, if the streets are in a rectangular grid. The Cartesian coordinate system is sometimes referred to as the rectangular coordinate system, since points are laid out in a rectangular grid. Recall from other studies that we use the origin  $(0,0)$  as our starting point and the two perpendicular lines, the  $x$  and  $y$  axes, as our frame of reference for every point. Each point is assigned two numbers, called an **ordered pair**. So in the diagram below the point P is assigned the ordered pair  $(4, 2)$ . The 4 is often called the  $x$ -coordinate and 2 the  $y$ -coordinate. The point Q is assigned  $(-3, -2)$ . If we combine an infinite number of these points together in a certain pattern we can draw lines or curves. Thus the points  $(1, 1)$ ,  $(2, 2)$ ,  $(10, 10)$  etc. lie on a straight line and the relationship between the coordinates can be expressed algebraically as  $y = x$ . In following sections we will look at lines and curves in more detail.

**Figure 5.1:** Example of the cartesian coordinate system

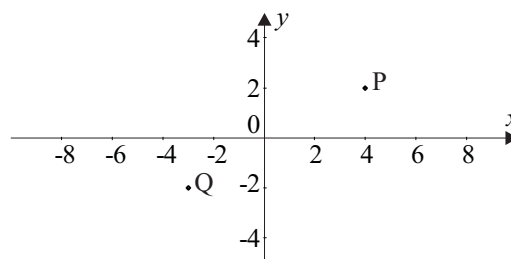

### 5.1.2 Polar coordinates

Back in our taxi, if we said to the driver ‘*Look, I don’t know how to get there but, as the crow flies, it’s about 5 kilometres in that direction (pointing about  $30^\circ$  north of east)*’. Given your information, the taxi driver could identify that position using his street directory. The coordinates that give a magnitude and direction from a starting position are called **polar coordinates**.

If our starting position is O and the final position is P then we now have two pieces of information with regard to the point P:

- the distance from the origin is 5, and
- the angle which is  $30^\circ$  north of east.

So our frame of reference is now a point (the origin) and a directed line (in this case the line pointing east) i.e., a given distance from a point and a given angle from the directed line.

**Figure 5.2:** Point in polar coordinates

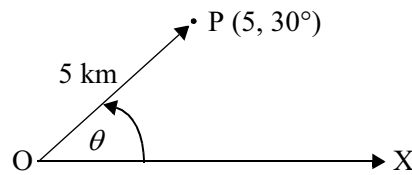

With these two pieces of information alone i.e. the distance and the angle, we can position the point P as in figure 5.2. If we define our point P as  $(5, 30^\circ)$ , these are called the **polar coordinates** of the point P, the first coordinate being the distance from the origin and the second being the angle moving anticlockwise from the directed line OX (called the **polar axis**). This idea was first suggested by Newton in about 1671 and is now used extensively in surveying and engineering.

You can also plot points on special polar graph paper, as seen in figure 5.3.

**Figure 5.3:** Point on polar coordinate graph paper

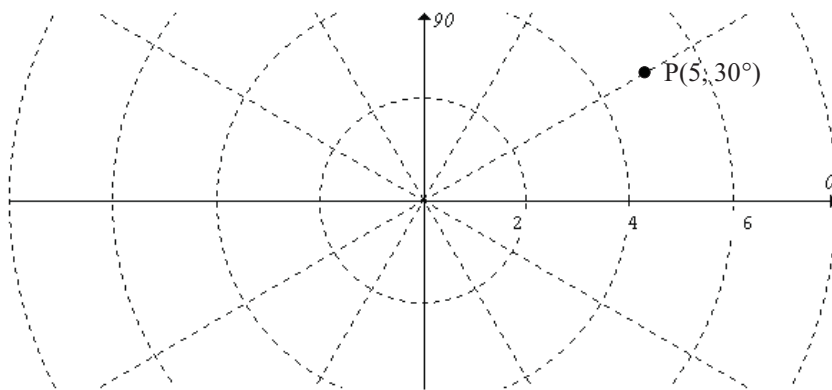

If the point P had the rectangular coordinates  $(x, y)$  and the distance from the origin was  $r$  with an angle of  $\theta$ , then the point in polar coordinates would be  $(r, \theta)$ . With rectangular coordinates, each point is uniquely defined by the ordered pair  $(x, y)$ . This is not true for polar coordinates. The point  $(r, \theta)$  can be represented by  $(r, \theta + 360^\circ)$  or any other angle that is coterminal with it (as we go round and round the circle). We could also represent the point in terms of negative angles. Point P in figure 5.3 could be  $(5, -330^\circ)$ .

**Figure 5.4:** Point P with coterminal angles

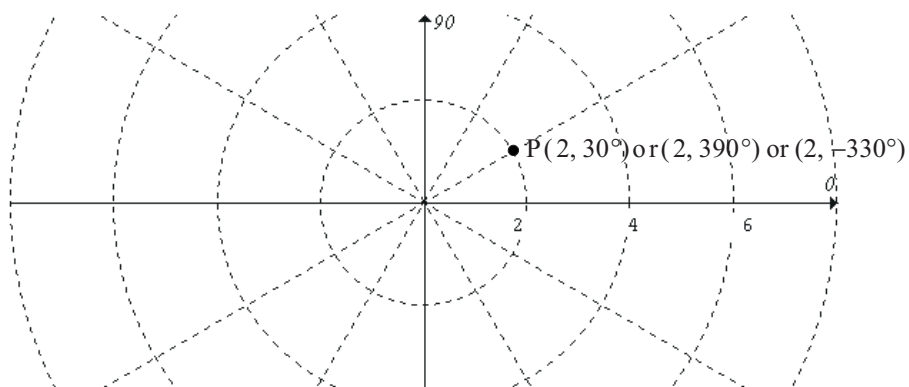

For example, in figure 5.4 the point P could be shown as  $(2, 30^\circ)$ ,  $(2, 390^\circ)$ ,  $(2, -330^\circ)$  etc.

### Activity 5.1

1. Estimate the polar coordinates of M, N, Q and P in the following graph. Give 3 different possibilities for each: a first revolution answer; an answer with a coterminal angle and an answer with a negative angle.

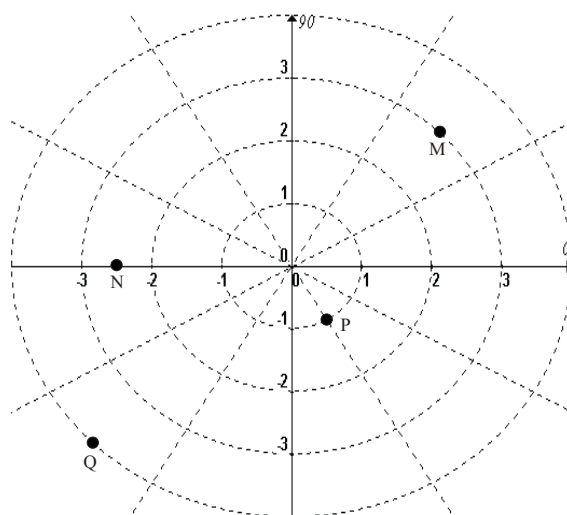

2. Use a polar grid to plot the points  $R(3, 60^\circ)$ ,  $S(4, 150^\circ)$  and  $T(1, -90^\circ)$ .

But how do we interpret these polar coordinates in terms of the rectangular coordinates we have used so far?

The relationship between the two coordinate systems can be found using trigonometry.

In figure 5.5, P is the point (4, 3). Using Pythagoras' theorem we can find the length OP as 5 units ( $\sqrt{3^2 + 4^2}$ ). If we label the angle between the  $x$  axis and the line OP as  $\theta^\circ$ , then

$$\cos \theta = \frac{4}{5}$$

$$\theta = \cos^{-1}\left(\frac{4}{5}\right)$$

$$\theta \approx 37^\circ$$

**Figure 5.5:** The point P in rectangular coordinates

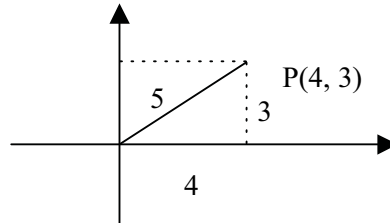

In polar coordinates the point now becomes  $P(5, 37^\circ)$ .

Let's now generalise this. In figure 5.6, P is the point  $(x, y)$ . Using Pythagoras' theorem, we can find the length OP as  $r$  ( $r = \sqrt{x^2 + y^2}$ ). If we label the angle between the  $x$  axis and the line OP as  $\theta$ , then from the figure 5.6 can you see that:

$$\cos \theta = \frac{x}{r}$$

$$x = r \cos \theta \quad \text{-- (i) and}$$

$$\sin \theta = \frac{y}{r}$$

$$y = r \sin \theta \quad \text{-- (ii)}$$

**Figure 5.6:** Point P with cartesian coordinates  $(x, y)$ ,  $r$  units from the origin

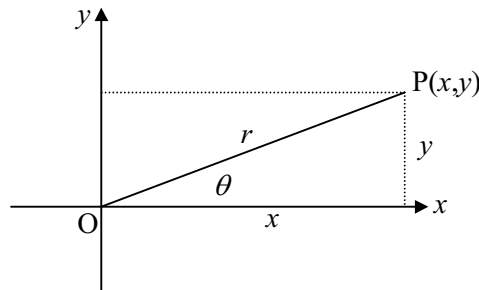

Note in the equations above,  $\theta$  can be expressed in radians or degrees. These last two equations are important to convert from rectangular to polar and from polar to rectangular coordinates, but they are also important in later mathematical concepts. We call these two equations **parametric equations**, since two new parameters  $r$  and  $\theta$  have been introduced into the relationships between  $x$  and  $y$ . We will revisit parametric equations in a later section.

Many scientific calculators are able to convert from rectangular to polar coordinates. These calculators usually have an R $\rightarrow$ P and P $\rightarrow$ R button. Check your calculator for these buttons and practice their use in the activities below. Check with your tutor if you have any difficulties.

**Example**

Convert  $(8, -2)$  into polar coordinates (both in degrees and radians).

$$\begin{aligned} r &= \sqrt{8^2 + (-2)^2} \\ &= \sqrt{64 + 4} \\ &= \sqrt{68} \\ &\approx 8.25 \end{aligned}$$

$$\begin{aligned} \cos \theta &= \frac{x}{r} \\ &= \frac{8}{\sqrt{68}} \\ &\approx 0.97 \\ \theta &\approx \cos^{-1} 0.97 \\ &\approx 14^\circ \end{aligned}$$

(You could check this result by using  $\sin \theta = \frac{y}{r}$ )

Since  $(8, -2)$  is in the 4th quadrant then in polar coordinates the point is approximately  $(8.25, -14^\circ)$  or  $(8.25, 346^\circ)$

You could also give this answer in radians:

$$\begin{aligned} \cos \theta &\approx 0.97 \\ \theta &\approx 0.25 \text{ radians} \end{aligned}$$

Therefore,  $(8, -2)$  in polar coordinates is approximately  $(8.25, 0.25)$ . Note there is no degree sign above the 0.25, so you can assume it is in radians.

## Activity 5.2

---

1. Convert from rectangular to polar coordinates

- (a) (i)  $(-1, 1)$       (ii)  $(-0.5, -1)$       (iii)  $(0, 0.2)$  showing all working  
 (b) (i)  $(3, 4)$       (ii)  $(1, \sqrt{3})$  using the rectangular/polar conversion keys on your calculator.

2. Convert from polar to rectangular coordinates

- (a) (i)  $(3, 30^\circ)$       (ii)  $(2, 89^\circ)$       (iii)  $(1, \frac{4\pi}{3})$  showing all working  
 (b) (i)  $(1.5, 3\pi)$       (ii)  $(2, -120^\circ)$  using the rectangular/polar conversion keys on your calculator.

### 5.1.3 Vectors

Before we move away from our study of points, there is one more way in which we can describe a point. This is through vectors. Vectors are not just ways of describing points, but a study of vectors (called vector analysis) allows us to describe and quantify many concepts in the physical world. In this unit we will only be touching on the elementary aspects. First, let's investigate the concept of a vector.

Tip for success.

There are a number of new terms introduced in this section.

Make sure you understand these terms. Have you a notebook of examples and new terms?

In this and other studies, we have investigated objects which require only one measure. Examples of these are angles, lengths, areas, masses, times and temperatures. These measures are called **scalars**, since the object is measured on a given scale.  $70^\circ$ ; 25 cm; 4 cubic metres are all scalars. Notice they all require only one single measure and they do not need any statement about direction. Often, we need more than one measure, for example, the location of a point in space, the acceleration of a particle, the motion of an object in a particular direction. To describe these measures, a new concept called vectors was developed in the 19th century and is now an essential tool for today's engineers, mathematicians, physicists and economists.

To explain what a vector is, let's go back to our taxi scenario. You are in a taxi (call this position O) 5 kilometres from your destination,  $40^\circ$  north of east (call this position P). The distance from O to P is 5 kilometres and the direction is  $40^\circ$  north of east. A distance that has direction is called **displacement**. We can depict this as a **vector**. In figure 5.7, the line with an arrow represents the vector.

Figure 5.7: Vector OP

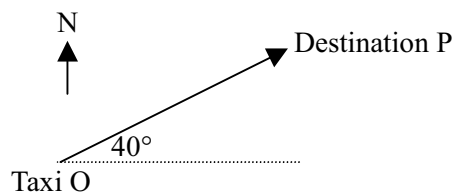

The word vector comes from a Latin word meaning to carry. So in mathematics, it has the connotation that something is carried off for a certain distance in a certain direction. It is important to note that a vector carries two pieces of information – a magnitude and a direction (the same information as in polar coordinates). In the taxi example it is a length and direction.  $\overline{OP}$  is called a **displacement vector**. The diagram below shows how vectors are depicted.

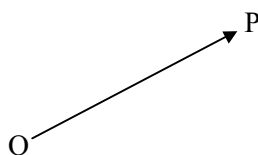

The arrow on the line shows the direction of the vector and the letters O and P indicate the **tail** and **head** of the vector, respectively.

If the taxi driver decided to return to the original position (at O) after dropping you off (at P), then the distance will be 5 km, but the direction will be  $40^\circ$  south of west (opposite to the original direction). The vector depicting this will be:

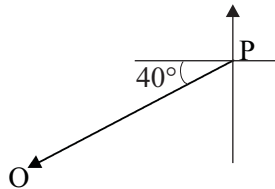

The name of this vector is  $\overrightarrow{PO}$ . Notice the length of the line segment is the same, but the arrowhead is at O.

Vectors are a really useful way of describing quantities that have both magnitude and direction not only in the fields of physics and engineering but also in business and economics. In the example above we looked at displacement vectors. But we could also think of the following as examples of vectors

- Velocity – a wind blowing at 20 km/h in an easterly direction
- Acceleration – a car travelling at 4 metres per second per second in an easterly direction
- Force – a force of 20 Newtons is exerted on a 4 kg body at an angle of  $20^\circ$ .
- Magnetic fields – at 0.9 Teslas in an easterly direction.
- Revenue – revenue collected from different outlets on different items.

### Example

Which of the following are vectors?

The volume of a pool is 2 megalitres.

The displacement of town A from town B is 50 km,  $20^\circ$  east of north.

The temperature of the ground is  $-10^\circ\text{C}$ .

The first example is a scalar since it only depicts the amount of water in the pool.

The second example is a vector since it depicts both magnitude and direction.

The third is a scalar since it only gives the magnitude of the temperature of the soil.

### Activity 5.3

---

1. Which of the following are **vectors** and which are **scalars**? Give reasons for your answers.

The distance from my house to work is 10 km.

It took 25 seconds to run the race.

The rocket went 100 metres per second, straight up.

A sled weighing 240 kg is pushed 2.3 metres by a constant force of 130 Newtons.

(One Newton is approximately the force required to lift a mass of 0.1kg.).

The block of concrete weighed 1.2 tonnes.

The acceleration due to gravity on the moon is  $1.6 \text{ ms}^{-2}$ ,

He went  $30^\circ$  west of south.

One important point to note about vectors is that they represent magnitude and direction, but in a plane they can be placed anywhere, their position does not matter. We call these **free vectors**. Look at the figure 5.8. In each case the lines represent the same vector, since they are the same in both magnitude and direction. The difference is their origin point. For example, if we blast a rocket vertically up in space with a certain force, the vector depicting this force will be the same whether the rocket is in Cape Canaveral or Woomera. However, there is an obvious difference since the forces start at different origin points. So far we have been looking at free vectors. If we can position these vectors in a reference system – the Cartesian plane, then we can describe a vector using this system.

**Figure 5.8:** Equivalent free vectors

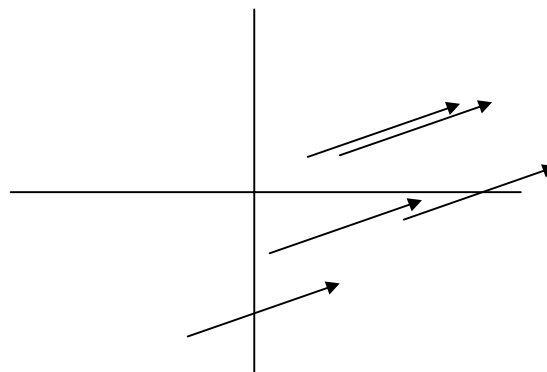

But what do vectors have to do with points? A vector is a quantity that has magnitude and direction; it can tell us how to get from one point to another. But in the Cartesian coordinate system we can describe the position of a point by a single vector if we think of it as the displacement of the point relative to the origin. In this case the vector is called a **position vector**.

The vector  $\overline{OP}$  can be placed anywhere, as in figure 5.8, but if we placed it in the Cartesian coordinate system with O as the origin, then we have the diagram in figure 5.9.

**Figure 5.9:** The position vector  $\overline{OP}$

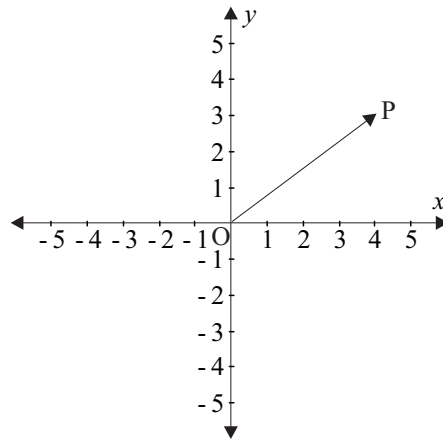

If P is the point (4, 3), we can call the displacement of the point from O (the origin) to the point P, the **position vector**  $\overline{OP}$ .

One way to depict the value of this vector is  $\begin{pmatrix} 4 \\ 3 \end{pmatrix}$ . Have you seen this notation before? From your previous studies you should have recognised this as a  $2 \times 1$  matrix (2 rows and 1 column). If you are unsure of matrices have a look at module 2 or contact your tutor.

Recall that a matrix can be a way of storing numbers, so the matrix  $\begin{pmatrix} 4 \\ 3 \end{pmatrix}$  by itself is just a set of numbers. However, if  $\begin{pmatrix} 4 \\ 3 \end{pmatrix}$  is described as a **position vector** then it means a point has moved from the origin, 4 units in the positive direction of the  $x$  axis and 3 units in the positive direction of the  $y$  axis.

**Something to talk about...**

Do you know the difference between a position vector and a displacement vector? Could you explain this difference to a friend?

**Example**

Find the magnitude of the vector  $v = \begin{pmatrix} 5 \\ -2 \end{pmatrix}$ .

If we depict the vector on the Cartesian plane, then we can see clearly that to find the magnitude of the vector, we can use Pythagoras' theorem. The notation for the magnitude of a vector is the absolute value symbol  $| |$ , so in this case we want to find  $|\vec{v}|$ . The arrow above the  $v$  indicates that it is a vector.

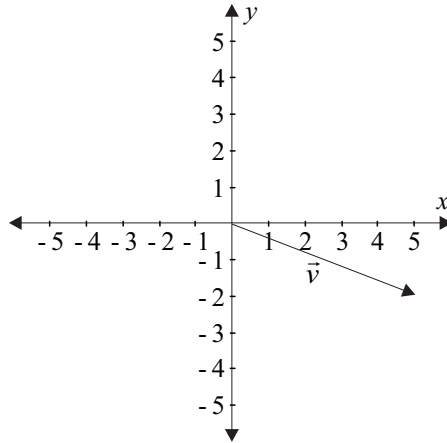

$$\begin{aligned} |\vec{v}| &= \sqrt{5^2 + (-2)^2} \\ &= \sqrt{29} \\ &\approx 5.4 \\ \cos \theta &= \frac{5}{\sqrt{29}} \\ &\approx 0.9285 \\ \theta &\approx 21.8^\circ \end{aligned}$$

The magnitude of the vector is approximately 5.4 units and, since  $\theta$  is in the 4th quadrant, the direction of the vector is  $-21.8^\circ$ .

### Activity 5.4

1. Find the magnitude of the following position vectors:

(a)  $\begin{pmatrix} 5 \\ 12 \end{pmatrix}$       (b)  $\begin{pmatrix} -\sqrt{3} \\ 1 \end{pmatrix}$       (c)  $\begin{pmatrix} -2a \\ -m \end{pmatrix}$

2. Vector  $\vec{v} = \begin{pmatrix} t \\ 3 \end{pmatrix}$  and  $|\vec{v}| = 7$ . Find the value of  $t$ .

If, back in our taxi, we had said we wanted to go 5 km  $40^\circ$  north of east, the taxi driver would have had to translate it back into number of kilometres east and number of kilometres north

(assuming a rectangular road system). If we let  $x$  be the number of kilometres east and  $y$  the number of kilometres north (see figure 5.10) then we could find  $x$  and  $y$  by using the parametric equations:  $x = r \cos \theta$  and  $y = r \sin \theta$  (see section 5.1.2).

**Figure 5.10:** Resolving the vector into components

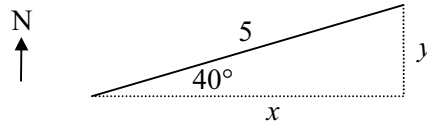

$$x = 5 \cos 40^\circ$$

$$x \approx 3.83$$

and  $y = 5 \sin 40^\circ$

$$y \approx 3.21$$

So the taxi travels approximately 3.83 kilometres east and 3.21 kilometres north. In vector terminology, this is called **resolving a vector** into its components. Instead of using the compass directions, we introduce a new term called the unit vector.

Two possible **unit vectors** are called  $\vec{i}$  and  $\vec{j}$ .  $\vec{i}$  is a free vector parallel to the  $x$ -axis and  $\vec{j}$  is a free vector parallel to the  $y$ -axis. Both are one unit long and travel in the positive direction of the axes, as seen in figure 5.11.

**Figure 5.11:** Unit vectors  $\vec{i}$  and  $\vec{j}$

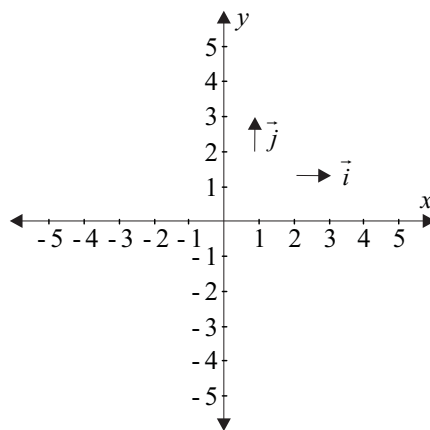

If we had a vector  $\overline{AP}$  which is 5 units long travelling parallel to the positive direction of the  $x$ -axis then it becomes five times the unit vector  $\vec{i}$  or  $5\vec{i}$  (see figure 5.12). If we had another vector  $\overline{BQ}$  which was 4 units long, travelling parallel to the negative direction of the  $y$ -axis, then it becomes  $-4\vec{j}$  (see figure 5.12). Note the numbers 5 and 4 are scalars since they just give the magnitude of the vector. The negative indicates the direction of the  $\vec{j}$ .

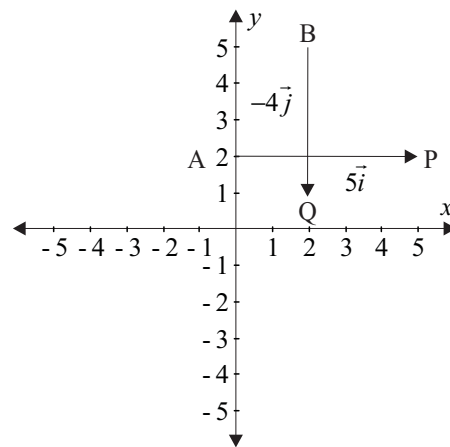
**Figure 5.12:** Vectors  $\overline{AP}$  and  $\overline{BQ}$ 

Remember we can place vectors (free vectors) anywhere we like, the vectors can be positioned as in 5.13, where the points P and B are coincident (i.e., at the same point) or in any other position.

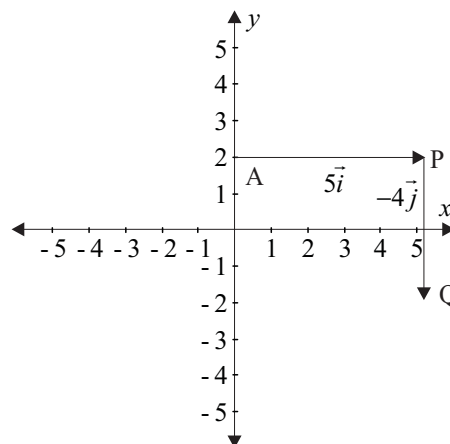
**Figure 5.13:** Vectors  $\overline{AP}$  and  $\overline{PQ}$ 

In the taxi scenario we can depict the displacement by breaking it down into its horizontal and vertical components and using these unit vectors (see figure 5.14).

So the vector depicting the displacement from the start to the destination becomes  $(3.83\vec{i} + 3.21\vec{j})$ . We put a '+' between the components, but vector arithmetic is a topic that will be left for your future mathematics studies.

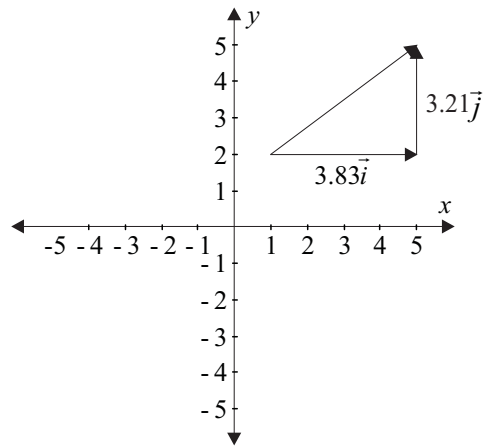
**Figure 5.14:** Displacement vector resolved into its horizontal and vertical components**Example**

If A is the point (5, -9) and B is the point (6, 1), what is the vector depicting the displacement from A to B (in  $x\vec{i} + y\vec{j}$  form)? What is the displacement from B to A?

The horizontal distance from A to B is 1 and the vertical distance is 10, so the vector is  $\overline{AB} = 1\vec{i} + 10\vec{j}$  and  $\overline{BA} = -1\vec{i} - 10\vec{j}$ .

**Activity 5.5**

- Resolve the following vectors into horizontal and vertical components and write in  $x\vec{i} + y\vec{j}$  form:
  - $\vec{a} = (3, 30^\circ)$
  - $\vec{b} = (2, 220^\circ)$
  - $\vec{c} = \begin{pmatrix} -2 \\ 0 \end{pmatrix}$
- Peter is trying to locate his lost wallet. He is told that it is in a letterbox exactly 7 km away as the crow flies. He is also told that if he drives 5 km West of his present position, O, and turns North he should be able to find the wallet. Assuming East and North coincide with the x and y axes respectively, write the location of the wallet in component form.
- Find the free vector depicting the displacement from the point A(3,1) to the point B(-1,5).

**For your interest only...**

We still don't have enough information to help us with positioning a point in space, since we have only been positioning our points in 2 dimensions. If we introduce a new dimension to our studies, called, unsurprisingly, the  $z$ -axis, then we can describe a point in 3 dimensional space. We will **not** be examining three dimensional geometry here except to say that it exists and follows the conventions we have been using. So the point  $(2, 5, 7)$  represents a point in space and this can be represented by the position vector depicted as a

column matrix  $\begin{pmatrix} 2 \\ 5 \\ 7 \end{pmatrix}$  or,  $2\vec{i} + 5\vec{j} + 7\vec{k}$  where  $\vec{k}$  becomes the unit vector on the  $z$ -axis.

We could also depict this in polar coordinates. So the point  $(5, 45^\circ, 15^\circ)$  is the point 5 units from the origin,  $45^\circ$  anticlockwise from the  $x$ -axis in the  $xy$ -plane and  $15^\circ$  from the  $xy$ -plane.

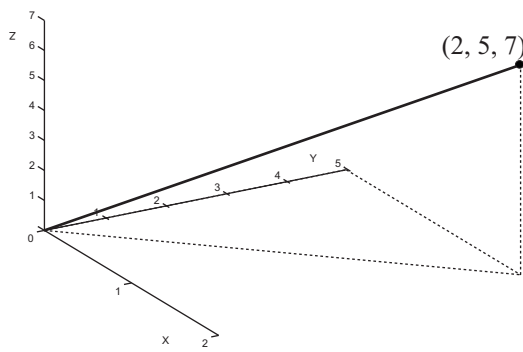
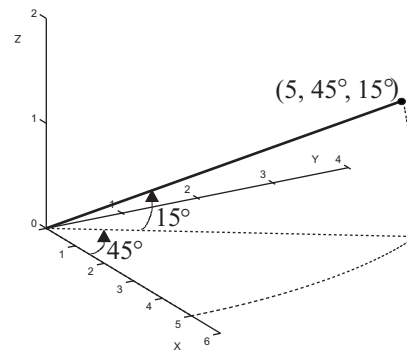
**Figure 5.15:****Figure 5.16:**

Summarising so far:

If we have a point  $P(x, y)$  which is  $r$  units from the origin  $O$ , and  $\theta$  is the angle between the positive direction of the  $x$ -axis and the line  $OP$ , then we can depict  $P$  in the following ways:

- $P$  can be in the Cartesian coordinate system with the coordinates  $(x, y)$ .
- $P$  can be in the polar coordinate system with coordinates  $(r, \theta)$ . The relationship between  $x, y, r$  and  $\theta$  is found in the parametric equations:  $x = r \cos \theta$  and  $y = r \sin \theta$ .
- $P$  can be positioned in terms of a position vector  $\vec{OP}$  or  $\begin{pmatrix} x \\ y \end{pmatrix}$  or  $x\vec{i} + y\vec{j}$ , where the magnitude of the vector is  $r$  given by  $\sqrt{x^2 + y^2}$  and the direction of the vector is  $\theta$ .

In the following section we will use rectangular and polar coordinates, as well as vectors and matrices to help describe lines and curves.

## 5.2 Describing straight lines

### 5.2.1 Equation of a straight line

In the previous section we described points using the Cartesian coordinate system, polar coordinates and vectors. In this section we will extend these descriptors from points to straight lines.

You have already studied straight lines and their parameters in module 3. In the line  $y = mx + c$ ,  $y$  is the dependent,  $x$  is the independent variable and  $m$  and  $c$  are the parameters which determine the shape of the line, i.e.,  $m$  is the gradient and  $c$  is the  $y$ -intercept.

If we had a point P (4, 3) then the equation of the line segment that joins O (the origin) to P would be  $y = \frac{3}{4}x$ ;  $0 \leq x \leq 4$ . In this case the  $\frac{3}{4}$  is the gradient of the line.

As you go on to do more mathematics, you will find that extra parameters will be introduced to describe the behaviour of lines and curves. Vectors are a useful way of dealing with these extra parameters. Let's investigate how we could use vectors to depict straight lines. We have already used matrices to depict position vectors in the previous section. From your previous studies we have seen the matrix equation:

$$\begin{pmatrix} x \\ y \end{pmatrix} = \begin{pmatrix} 4 \\ 3 \end{pmatrix}. \text{ We can again think of this in the Cartesian coordinate system and consider } \begin{pmatrix} x \\ y \end{pmatrix}$$

as the position vector of any point in the  $xy$ -plane. We can now call  $\begin{pmatrix} x \\ y \end{pmatrix} = \begin{pmatrix} 4 \\ 3 \end{pmatrix}$  a vector

equation which is really just identifying the position vector  $\begin{pmatrix} 4 \\ 3 \end{pmatrix}$ . In a real world situation this could be thought of as the position of an aeroplane 4 kilometres east and 3 kilometres north of its original position.

Now take this original equation and consider the following vector equations:

$$\begin{pmatrix} x \\ y \end{pmatrix} = 0.5 \begin{pmatrix} 4 \\ 3 \end{pmatrix} = \begin{pmatrix} 2 \\ 1.5 \end{pmatrix}$$

$$\begin{pmatrix} x \\ y \end{pmatrix} = 2 \begin{pmatrix} 4 \\ 3 \end{pmatrix} = \begin{pmatrix} 8 \\ 6 \end{pmatrix}$$

$$\begin{pmatrix} x \\ y \end{pmatrix} = 5 \begin{pmatrix} 4 \\ 3 \end{pmatrix} = \begin{pmatrix} 20 \\ 15 \end{pmatrix}$$

If we plot points from these position vectors on the Cartesian plane, and join the points, we would end up with a straight line.

**Figure 5.17:** Graph of  $\begin{pmatrix} x \\ y \end{pmatrix} = t \begin{pmatrix} 4 \\ 3 \end{pmatrix}$  with Domain  $0 \leq x \leq 20$

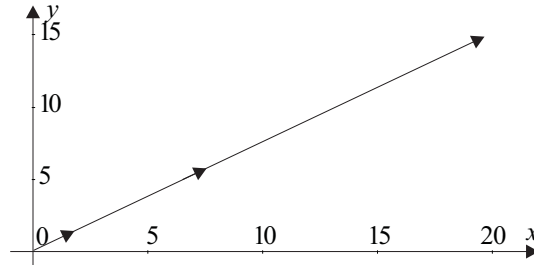

The **vector equation** of this line would be  $\begin{pmatrix} x \\ y \end{pmatrix} = t \begin{pmatrix} 4 \\ 3 \end{pmatrix}$ . We have now introduced another parameter  $t$  which is a scalar.

Can you interpret this?

You could say something like: ‘The  $\begin{pmatrix} 4 \\ 3 \end{pmatrix}$  gives the direction, i.e., from the origin go 4 units horizontally and 3 units vertically  $t$  number of times.’

In our aeroplane scenario you could say the position of the aeroplane,  $t$  minutes after commencing its flight, is given by the equation  $\begin{pmatrix} x \\ y \end{pmatrix} = t \begin{pmatrix} 4 \\ 3 \end{pmatrix}$ , so after one minute you could say the displacement of the aeroplane is 4 kilometres east and 3 kilometres north of its starting point.

This idea of introducing a new parameter, especially time, is very important as you do further studies, especially in science and engineering. The Global Positioning System relies on it, in fact any mathematics involving motion will often have equations expressed in this way.

Can you see the relationship between the vector equation above and the equation  $y = \frac{3}{4}x$  (in Cartesian mode)?

Look at the vector equation  $\begin{pmatrix} x \\ y \end{pmatrix} = t \begin{pmatrix} 4 \\ 3 \end{pmatrix}$ . From your knowledge of matrices (which operate in much the same way as vectors), you could say that:

$$\begin{pmatrix} x \\ y \end{pmatrix} = \begin{pmatrix} 4t \\ 3t \end{pmatrix}$$

So we can then say:

$$x = 4t \quad - \text{ (i)}$$

$$y = 3t \quad - \text{ (ii)}$$

These above two equations are the parametric forms of the vector equation.

From equation (i)  $t = \frac{x}{4}$

Substitute for  $t$  in equation (ii)

$$y = 3 \times \frac{x}{4}$$

$$y = \frac{3}{4}x$$

This is our equation in Cartesian mode.

So we can move from the equation in vector mode, to a parametric form to the Cartesian equation, depending on the context of our problem. So far in your mathematics learning, you have only needed to use ‘fairly’ simple equations, but as you advance you will need to choose from your mathematical tool box the most appropriate and easy to use tool. At times, you will find the vector form or the parametric form to be much more appropriate.

### Example

Graph the equation  $y = \frac{3}{4}x + 4$ . Express this in vector form using  $\begin{pmatrix} 0 \\ 4 \end{pmatrix}$  as a position vector of a particular point on the line. Express it in parametric form and verify your solution is correct.

**Figure 5.18:** Graph of  $y = \frac{3}{4}x + 4$

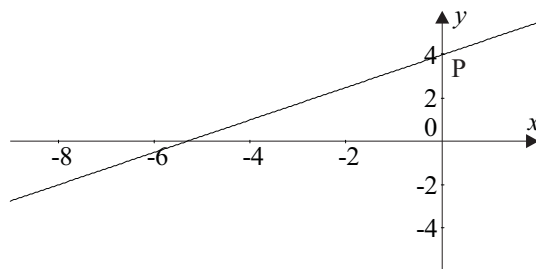

In vector form we start at P (0, 4) then move 4 units horizontally and 3 vertically  $t$  number of times. The equation then becomes:

$$\begin{pmatrix} x \\ y \end{pmatrix} = t \begin{pmatrix} 4 \\ 3 \end{pmatrix} + \begin{pmatrix} 0 \\ 4 \end{pmatrix}$$

Check by taking a value of  $t$  say  $-2$ :

$$\begin{aligned}\begin{pmatrix} x \\ y \end{pmatrix} &= -2\begin{pmatrix} 4 \\ 3 \end{pmatrix} + \begin{pmatrix} 0 \\ 4 \end{pmatrix} \\ &= \begin{pmatrix} -8 \\ -6 \end{pmatrix} + \begin{pmatrix} 0 \\ 4 \end{pmatrix} \\ &= \begin{pmatrix} -8 \\ -2 \end{pmatrix}\end{aligned}$$

Check that this point lies on the line.

The equation could also be written in vector form:

$$\begin{aligned}\begin{pmatrix} x \\ y \end{pmatrix} &= t\begin{pmatrix} 4 \\ 3 \end{pmatrix} + \begin{pmatrix} 0 \\ 4 \end{pmatrix} \\ &= \begin{pmatrix} 4t \\ 3t \end{pmatrix} + \begin{pmatrix} 0 \\ 4 \end{pmatrix} \\ &= \begin{pmatrix} 4t \\ 3t + 4 \end{pmatrix}\end{aligned}$$

In parametric form the equations will be:

$$\begin{aligned}x &= 4t \\ y &= 3t + 4\end{aligned}$$

From the first equation  $t = \frac{x}{4}$  substituting for  $t$  in the second equation gives us the Cartesian form of the equation  $y = \frac{3}{4}x + 4$ .

**Can you see that the vector equation  $\begin{pmatrix} x \\ y \end{pmatrix} = t\begin{pmatrix} 4 \\ 3 \end{pmatrix} + \begin{pmatrix} -4 \\ 1 \end{pmatrix}$  in the example above also depicts the same line but using a different position vector on the line.**

## Activity 5.6

1. Write the equation  $4y = x + 4$ 
  - (a) in vector form
  - (b) in parametric form.
2. Consider the equation  $y = \frac{2}{3}x - 1$ .
  - (a) Sketch the graph.
  - (b) Write the equation in vector form using parameter  $t$  and any suitable position vector
  - (c) Rewrite the equation in parametric form and verify your result is equivalent to the original equation.
  - (d) Which, if any, of the following depicts this same line:

$$(i) \begin{pmatrix} x \\ y \end{pmatrix} = t \begin{pmatrix} 2 \\ 3 \end{pmatrix} + \begin{pmatrix} 0 \\ -1 \end{pmatrix}$$

$$(ii) \begin{pmatrix} x \\ y \end{pmatrix} = t \begin{pmatrix} 3 \\ 2 \end{pmatrix} + \begin{pmatrix} 3 \\ 1 \end{pmatrix}$$

$$(iii) \begin{pmatrix} x \\ y \end{pmatrix} = t \begin{pmatrix} 3 \\ 2 \end{pmatrix} + \begin{pmatrix} 6 \\ 3 \end{pmatrix}$$

$$(iv) \begin{pmatrix} x \\ y \end{pmatrix} = t \begin{pmatrix} 3 \\ 2 \end{pmatrix} + \begin{pmatrix} -6 \\ -3 \end{pmatrix}$$

What we have seen in this section is that like points, lines can be expressed in different forms. As you study more mathematics, you will see that different forms become important in different situations.

Summarising so far:

A line can be expressed in the form of  $y = mx + c$ , where  $m$  and  $c$  are the parameters that determine the gradient and  $y$ -intercept respectively.

- A line can be expressed in terms of vectors  $\begin{pmatrix} x \\ y \end{pmatrix} = t \begin{pmatrix} a \\ b \end{pmatrix} + \begin{pmatrix} p \\ q \end{pmatrix}$  where  $\begin{pmatrix} p \\ q \end{pmatrix}$  is the position vector of a particular point on the line,  $\begin{pmatrix} a \\ b \end{pmatrix}$  is a vector that gives the direction of the line and  $t$  is a parameter determining the size of the line.
- A line can be expressed in terms of another parameter, giving a set of parametric equations:

$$x = at + p$$

$$y = bt + q$$

## 5.2.2 Distance between points

Before we move on to an investigation of curves, let's look at two tools which are useful to investigate the characteristics of straight lines. That is finding the length of a line segment and its mid-point.

You have already found the distance between a point and the origin using Pythagoras' theorem in section 5.1.2. We will now expand this to find the distance between any two points.

**Figure 5.19:** Line segment PQ

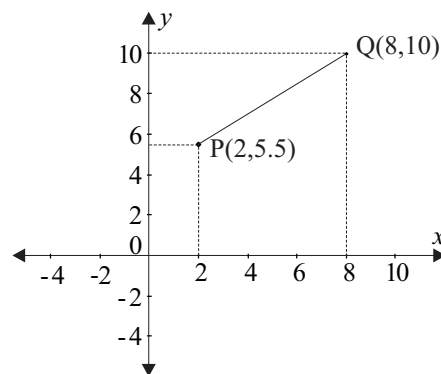

In figure 5.19, P is the point (2, 5.5) and Q is the point (8, 10). To find the distance between the points, we set up a right-angled triangle with P and Q as the end points of the hypotenuse and R as the third corner (see figure 5.20). By subtracting the coordinates of the points we find  $\overline{QR} = 4.5$  and  $\overline{PR} = 6$  (the symbolism for length of line segment is a line above the two end points).

**Figure 5.20:** Finding the length of PQ by subtracting the coordinates

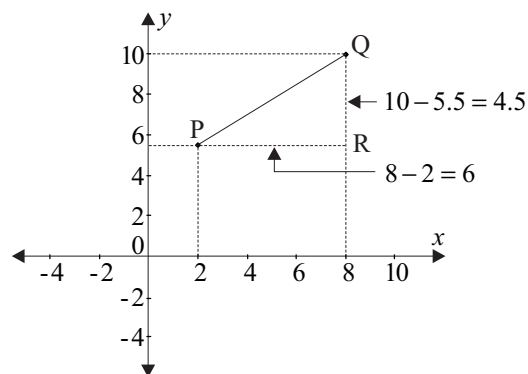

To find the length of the hypotenuse we use Pythagoras' Theorem.

$$\begin{aligned}PQ^2 &= 6^2 + 4.5^2 \\ \overline{PQ} &= \sqrt{6^2 + 4.5^2} \\ &= \sqrt{36 + 20.25} \\ &= 7.5 \text{ units}\end{aligned}$$

Since we are dealing with a length of a line we are only concerned with the positive square root.

Now let's generalise this. If we had two points  $P(x_1, y_1)$  and  $Q(x_2, y_2)$  as in figure 5.21, the lengths of the sides  $\overline{QR}$  and  $\overline{PR}$  would be  $y_2 - y_1$  and  $x_2 - x_1$

**Figure 5.21:** Finding the length of a general line

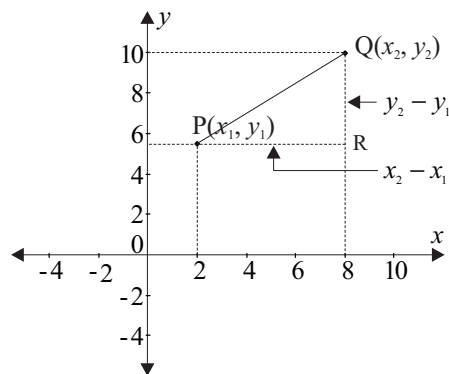

$$\begin{aligned}PQ^2 &= (x_2 - x_1)^2 + (y_2 - y_1)^2 \\ PQ &= \sqrt{(x_2 - x_1)^2 + (y_2 - y_1)^2}\end{aligned}$$

Taking only the positive square root.

For any two points the distance between them is found by using the formula:

$$\overline{PQ} = \sqrt{(x_2 - x_1)^2 + (y_2 - y_1)^2}$$

### Example

Find the distance between the points  $P(-2, 4)$  and  $Q(7, -6)$ .

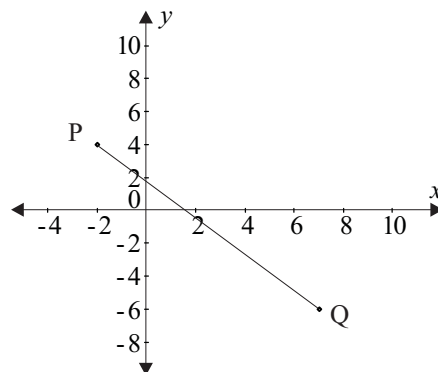
Figure 5.22: Line segment  $\overline{PQ}$ 

$P(x_1, y_1)$  and  $Q(x_2, y_2)$

↓ ↓            ↓ ↓

$P(-2, 4)$  and  $Q(7, -6)$

So, using the general formula with the appropriate substitution:

$$\begin{aligned} \overline{PQ} &= \sqrt{(x_2 - x_1)^2 + (y_2 - y_1)^2} \\ &= \sqrt{(7 - (-2))^2 + (-6 - 4)^2} \\ &= \sqrt{(9)^2 + (-10)^2} \\ &= \sqrt{181} \\ &\approx 13.5 \end{aligned}$$

The length of the line is approximately 13.5 units.

Notice that it doesn't matter which point you start with as long as you are consistent when substituting into the formula. In this case we are only concerned with the length of  $\overline{PQ}$ . So the length of  $\overline{PQ}$  is the same as the length of  $\overline{QP}$ .

However if we look at  $\overline{PQ}$  as a vector (i.e. as the displacement from P to Q, then  $\overline{PQ}$  is not the same as  $\overline{QP}$ . Can you see why?

This is because vectors have direction as well as magnitude.  $\overline{PQ}$  is going in an opposite direction from  $\overline{QP}$ . The magnitude itself (i.e., the length of the vector), however is the same.

## Activity 5.7

1. Find the distance between points S  $(-3, -1)$  and T  $(1.5, 3)$ .
2. Q is the point  $(\frac{3}{4}, -\frac{1}{2})$ . Find the magnitude (length) of the position vector  $\overline{OQ}$ .
3. A and B are points such that  $\vec{a} = 2\vec{i} + \vec{j}$  and  $\vec{b} = \vec{i} - 2\vec{j}$ . Find  $\overline{AB}$ .
4. Joe and Nadia start from the same position. While Joe walks 4 km in a NE direction, Nadia rides S30°W (i.e. 240°) for 10 km. How far apart are they at the finish?

### 5.2.3 Mid-point of a line

The second tool to use to investigate straight lines is the mid-point of a line.

**Figure 5.23:** M the mid-point of PQ

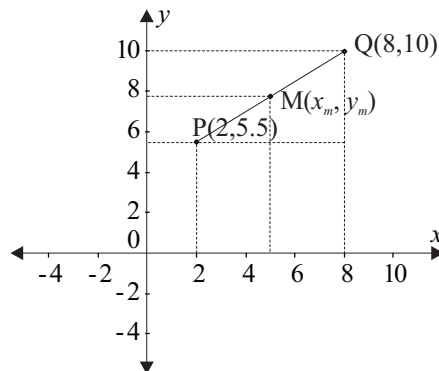

Suppose you want to find the mid-point (M) of the line  $\overline{PQ}$ . Look at the  $x$  and  $y$ -coordinates separately. From figure 5.23 you can see the horizontal distance between P and Q is 6. If the  $x$ -coordinate of the mid-point M is  $x_m$  then the distance between the  $x$ -coordinates of M and P is 3 (i.e., half of 6). To find the actual  $x$ -coordinate of M we then add 2 (the  $x$ -coordinate of P).

$$x_m - 2 = 3$$

$$x_m = 5$$

Do similar steps for the  $y$ -coordinate and find the value of the  $y$ -coordinate of M.

If you said 7.75 you would be right.

So the coordinates of the mid-point would be  $(5, 7.75)$ .

If we looked generally at two points  $P(x_1, y_1)$  and  $Q(x_2, y_2)$  with the mid-point being  $(x_m, y_m)$  the horizontal distance between the mid-point M and P is  $x_m - x_1$ .

**Figure 5.24:** M the mid-point of PQ, where P and Q are any points

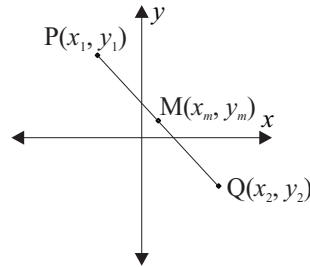

Similarly the horizontal distance between M and Q is  $x_2 - x_m$ .

Since these distance expressions are equal we can write:

$$x_2 - x_m = x_m - x_1$$

$$2x_m = x_1 + x_2$$

$$x_m = \frac{x_1 + x_2}{2}$$

Similarly for  $y$ :

$$y_2 - y_m = y_m - y_1$$

$$2y_m = y_1 + y_2$$

$$y_m = \frac{y_1 + y_2}{2}$$

So for any line segment (as depicted in figure 5.24), the mid point is:

$$\left( \frac{x_1 + x_2}{2}, \frac{y_1 + y_2}{2} \right)$$

## Activity 5.8

1. Find the mid-point of each of the segments described by the following points:

(a)  $A(0, 4)$ ,  $B(5, 1)$       (b)  $X(-2, 3)$ ,  $Z(4, -4)$       (c)  $R(-1, -3)$ ,  $S(-1, 6)$

(d)  $G(g, -g)$ ,  $H(-2g, g)$

2.  $\overline{OA} = \begin{pmatrix} 3 \\ 3 \end{pmatrix}$  and  $\overline{OB} = \begin{pmatrix} -2 \\ -3 \end{pmatrix}$ . Find  $\overline{OM}$  such that  $M$  is the mid-point of  $\overline{AB}$ .

3. Three of the vertices of the parallelogram OACB are O(0, 0), A(5, -2) and B(-1, 4). Find the coordinates of the point where the diagonals intersect. What are the coordinates of C?

## 5.3 Describing other curves

So far we have looked at points and straight lines, sometimes using new tools such as matrices and vectors. In module 3 you examined other curves i.e., polynomial, logarithmic exponential curves and rectangular hyperbola, and in module 4 you looked at trigonometric curves. Before we take a look at these from an analytical geometry perspective, we need to look at another family of curves: circles. We haven't investigated these before, since they are not functions, but they are important, as Osserman (1995) in his book, *Poetry of the Universe* states: 'Of all the shapes that were studied by mathematicians, one held a special fascination: the circle (and) was destined to play a powerful role... in the future attempts to describe the shape and workings of the world and the universe' (p. 7).

### 5.3.1 Circles

In section 5.2 we looked at the distance between two points, which relied on Pythagoras' Theorem. Now let's look at a series of right-angled triangles all with a hypotenuse of 1 and see how they relate to the circle. In each case below the hypotenuse is one unit but the other two sides (call their lengths  $x$  and  $y$ ) have changed in value. However they all satisfy the equation  $x^2 + y^2 = 1$ .

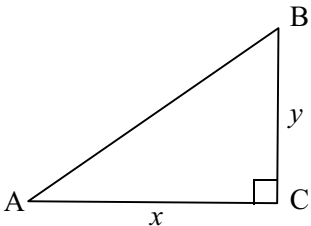
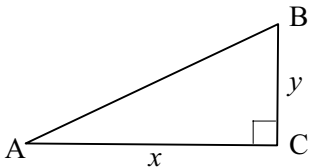
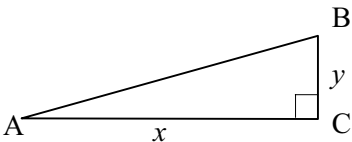
	$x = 0.707; y = 0.707$ $0.707^2 + 0.707^2 \approx 1$
	$x = 0.8; y = 0.6$ $0.8^2 + 0.6^2 = 1$
	$x = 0.90; y = 0.436$ $0.90^2 + 0.436^2 \approx 1$

Take different values of  $x$  and  $y$  and look what happens to point B of the triangle, if we keep A in the same position.

**Figure 5.25:** Right-angled triangles with different side lengths, but same hypotenuse

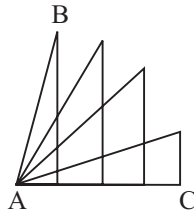

Can you see that point B traces a curve.

If we placed this in the Cartesian coordinate system with the point A as the origin, then we can continue making triangles in the other three quadrants.

**Figure 5.26:** Right-angled triangles with different side lengths, same hypotenuse, inscribed in a circle

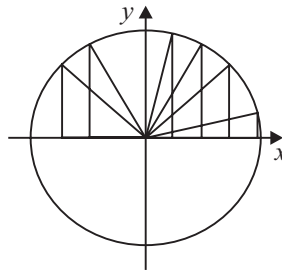

The point B now traces a circle with the radius being the hypotenuse of the triangle. Can you see what the coordinates of the point B are? It's the point  $(x, y)$ .

So the equation  $x^2 + y^2 = 1$  is the equation to a circle with a radius of 1.

Try sketching this in Graphmatica. You should get a graph similar to the one in figure 5.27.

**Figure 5.27:** Graph of  $x^2 + y^2 = 1$

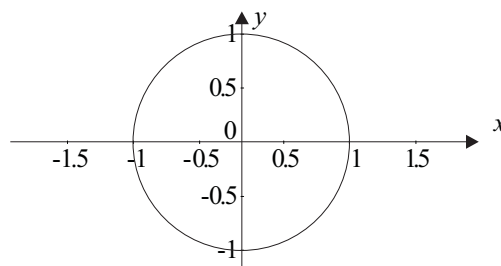

**Example**

Sketch the graph of  $x^2 + y^2 = 8$ . Confirm your sketch by using Graphmatica.

The radius of the circle will be  $\sqrt{8}$  or about 2.8. The sketch below is from Graphmatica.

**Figure 5.28:** Graph of  $x^2 + y^2 = 8$

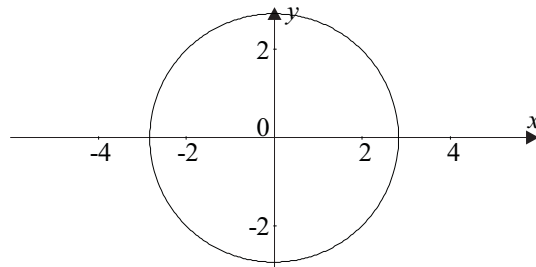

### Activity 5.9

---

1. Sketch the graphs:

(a)  $x^2 + y^2 = 4$       (b)  $x^2 + y^2 = 2.25$

2. Write the equation for the following circle:

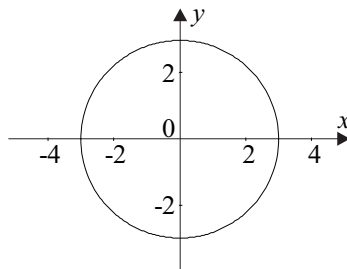

- A circle is centred at  $(0, 0)$  and has a radius of 2.5. Write its equation.
- What is the equation of the circle, centre  $(0, 0)$ , passing through the point  $(-4, 3)$ ?

If we look at the right angled triangle again in the coordinate system, the point B could also be described in terms of its polar coordinates.

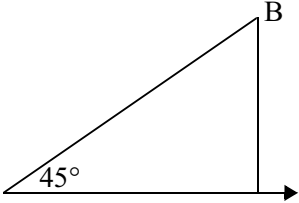
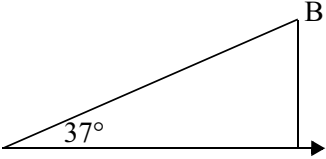
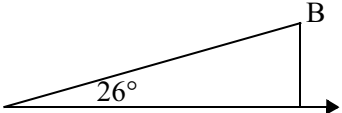
	Rectangular	Polar
	$x = 0.707; y = 0.707$ $0.707^2 + 0.707^2 \approx 1$ B is the point (0.707, 0.707)	$\tan \theta = 1$ $\theta = 45^\circ$ B is the point (1, $45^\circ$ )
	$x = 0.8; y = 0.6$ $0.8^2 + 0.6^2 = 1$ B is the point (0.8, 0.6)	$\tan \theta = \frac{0.6}{0.8}$ $\theta = \tan^{-1} 0.75$ $\approx 37^\circ$ B is the point (1, $37^\circ$ )
	$x = 0.90; y = 0.436$ $0.90^2 + 0.436^2 \approx 1$ B is the point (0.9, 0.436)	$\tan \theta = \frac{0.436}{0.9}$ $\theta = \tan^{-1} 0.484$ $\approx 26^\circ$ B is the point (1, $26^\circ$ )

So the points  $(1, 45^\circ)$ ;  $(1, 37^\circ)$ ;  $(1, 26^\circ)$  all lie on the circle  $x^2 + y^2 = 1$ . One of the advantages of thinking of curves in terms of polar coordinates is the simplicity of the equations. If we assume we are working in polar coordinates, the equation of a circle with a radius of 1 is  $r = 1$ . This is a lot simpler than the equation  $x^2 + y^2 = 1$ . In Graphmatica, if we type in  $r = 1 \{0, 2\pi\}$  ( $\{0, 2\pi\}$  specifies the domain in radians), then it will draw a circle just like the one in figure 5.27.

We can also draw the circle in terms of the parametric equations  $x = r \cos \theta$  and  $y = r \sin \theta$ . When the radius is 1 the equations become  $x = \cos \theta$  and  $y = \sin \theta$ . In Graphmatica type in  $x = \cos(t); y = \sin(t) \{0, 2\pi\}$ . Try this for different values of  $r$ .

We can also draw circles on polar coordinate graph paper. In Graphmatica, change the graph paper to polar coordinates and type in  $r = 1$  (this is called a polar equation) and your graph should look like this.

Figure 5.29: Graph of a circle with a radius of one unit

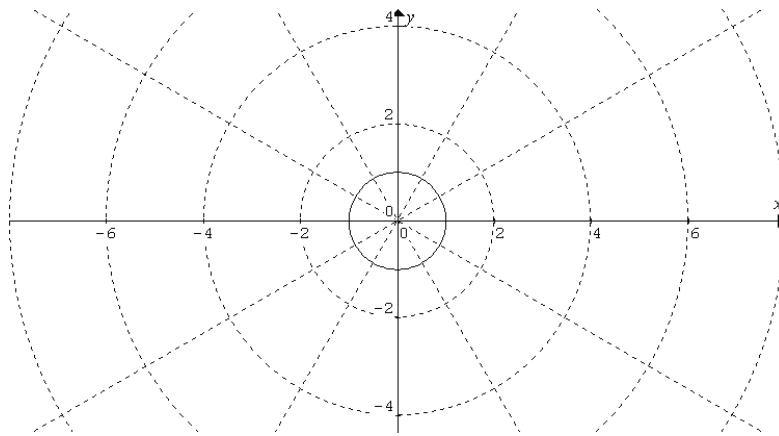

Notice the  $x$ - and  $y$ -axes are still present in Graphmatica, but points are plotted in accordance to  $r$  and  $\theta$ . Use the coordinate cursor to check the coordinates of some points.

### Activity 5.10

1. A target is made up of 3 concentric circles as shown. Write the equation of each.

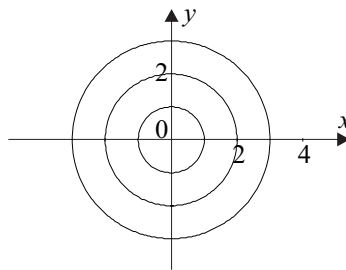

2. Write the parametric equations of circles, centre O, and:
  - (a) radius = 2
  - (b) radius 1.5
3. The point  $(5, -7)$  lies on a circle, centre O. Find the polar equation of the circle.

#### Time to reassess...

How are you going so far? Do you feel you have been swamped by new information! Now may be a good time to look at your notes again and see what you have learnt; how it all fits together. Maybe you want to look at some other material and see what they say about these concepts. If you have access to the Internet, why not go to some of the sites suggested in the introductory book. Ask your colleagues about these concepts, and where they fit into real world situations.

## 5.4 Transformations

In this section we will review some of the work you have done in previous sections and modules, but look at it from the perspective of geometric transformations. You may have come across the idea of transformations before in art, drawing or some computing programs where you wish to reflect, rotate, translate, enlarge, or stretch figures. All of these movements are called transformations. As you do more study you will see many instances where you will need to study mathematics involving movement. For example in the building construction industry when there is load on material a strain is produced (a change in shape); magnetic forces work in much the same way. In aerodynamics, the study of air flowing past aeroplane wings involves the changing shape of the air stream; similar forces work in hydrodynamics. Often times this movement can be manipulated more easily using matrices.

The following illustrations exemplify the transformations. For each of the transformations you may like to pick a point and see its new position in relation to the original one. We also express the points in terms of position vectors and the transformations in terms of matrices.

In each case we will present something for you to think about which will then be addressed in the activities.

### 5.4.1 Transforming points

#### Reflection

**Figure 5.30:** Shape under reflection in  $y$ -axis

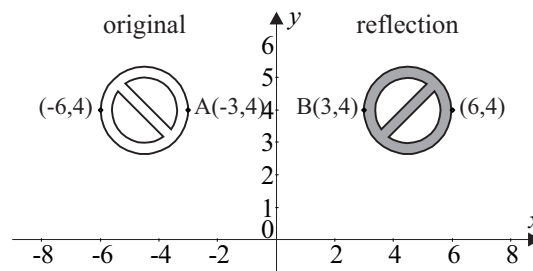

If we reflect the figure above in the  $y$ -axis, every  $y$ -coordinate remains the same. Every  $x$ -coordinate changes sign e.g., point A  $(-3, 4)$  becomes B  $(3, 4)$ .

How can matrices help us with reflecting points? If we depict the point A as the position

vector  $\begin{pmatrix} -3 \\ 4 \end{pmatrix}$  and the point B as the position vector  $\begin{pmatrix} 3 \\ 4 \end{pmatrix}$ , then how do we get from A into B?

i.e., from  $\begin{pmatrix} -3 \\ 4 \end{pmatrix}$  to  $\begin{pmatrix} 3 \\ 4 \end{pmatrix}$ ?

Since A and B are now in matrix form, we can use our knowledge of matrix multiplication to assist in this reflection.

Recall that we can multiply two matrices, C and A, together to obtain a third matrix, B, i.e.,  $CA = B$ . Now if A and B are both  $2 \times 1$  matrices, then C must be a  $2 \times 2$  matrix. What

$2 \times 2$  matrix would allow  $\begin{pmatrix} -3 \\ 4 \end{pmatrix}$  to be transformed to  $\begin{pmatrix} 3 \\ 4 \end{pmatrix}$ ?

Spent a few minutes (trial and error) seeing if you can find the values missing in the following:

$$\begin{pmatrix} ? & ? \\ ? & ? \end{pmatrix} \begin{pmatrix} -3 \\ 4 \end{pmatrix} = \begin{pmatrix} 3 \\ 4 \end{pmatrix}$$

Can you see that  $\begin{pmatrix} -3 \\ 4 \end{pmatrix}$  multiplied by the matrix  $\begin{pmatrix} -1 & 0 \\ 0 & 1 \end{pmatrix}$  will give the answer we want?

$$\begin{pmatrix} -1 & 0 \\ 0 & 1 \end{pmatrix} \begin{pmatrix} -3 \\ 4 \end{pmatrix} = \begin{pmatrix} -1 \times -3 + 0 \times 4 \\ 0 \times -3 + 1 \times 4 \end{pmatrix} = \begin{pmatrix} 3 \\ 4 \end{pmatrix}$$

Check that the point  $(-6, 4)$  is transformed to the point  $(6, 4)$  under the reflection  $\begin{pmatrix} -1 & 0 \\ 0 & 1 \end{pmatrix}$ .

Try doing this for a few more points to confirm your understanding.

#### Something to think about...

We can also reflect our figure in the  $x$ -axis or in any other line we like to draw. What would be the reflection of the point  $(-3, 4)$  in the  $x$ -axis? There is a  $2 \times 2$  matrix similar to the one above which produces this reflection in the  $x$ -axis. See if you can guess what it is. If we reflect a point in the line  $y = x$ , what will be the new point? Can you find a  $2 \times 2$  matrix that will do this reflection? What does this tell us about inverse relations?

We will address these reflections in activity 5.11.

## Rotation

**Figure 5.31:** Shape under rotation of  $45^\circ$  in an anticlockwise direction

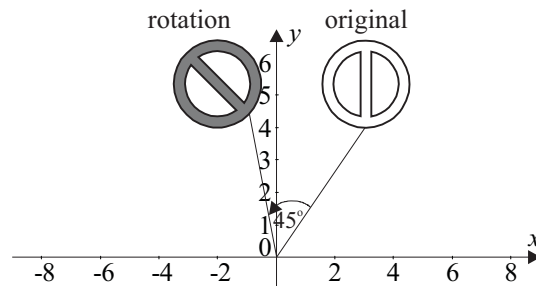

If we take the figure above and rotate it anticlockwise about the origin through an angle of  $45^\circ$ , both the  $x$  and  $y$ -coordinates change but the distance from the origin does not.

For example the point  $(5, 80^\circ)$  (in polar coordinates) becomes  $(5, 125^\circ)$ . If we take the point  $(-3, 4)$  using the same rotation, what is the new point? We could change the point to polar coordinates then do the transformation, or we could use a matrix. The matrix multiplication is a bit complex at this stage, so it is just included for your interest. You may study this in more depth in further maths study.

**For your interest only. You do not have to learn this:**

If we take the position vector  $\begin{pmatrix} -3 \\ 4 \end{pmatrix}$  and multiply it by the matrix  $\begin{pmatrix} \cos 45^\circ & -\sin 45^\circ \\ \sin 45^\circ & \cos 45^\circ \end{pmatrix}$

Then we get

$$\begin{pmatrix} \cos 45^\circ & -\sin 45^\circ \\ \sin 45^\circ & \cos 45^\circ \end{pmatrix} \begin{pmatrix} -3 \\ 4 \end{pmatrix} = \begin{pmatrix} -3 \cos 45^\circ - 4 \sin 45^\circ \\ -3 \sin 45^\circ + 4 \cos 45^\circ \end{pmatrix}$$

$$= \begin{pmatrix} \frac{-3}{\sqrt{2}} - \frac{4}{\sqrt{2}} \\ \frac{-3}{\sqrt{2}} + \frac{4}{\sqrt{2}} \end{pmatrix} = \begin{pmatrix} \frac{-7}{\sqrt{2}} \\ \frac{1}{\sqrt{2}} \end{pmatrix} \approx \begin{pmatrix} -4.95 \\ 0.71 \end{pmatrix}$$

**Something to think about...**

Can you find the rectangular coordinates of the point  $(-3, 4)$  after it was rotated as above through  $45^\circ$  without using matrices? Your answer should be the same as the one in the box above. We will address this rotation in activity 5.11.

## Translation

**Figure 5.32:** Shape under translation of 5 units in the positive direction of the x-axis

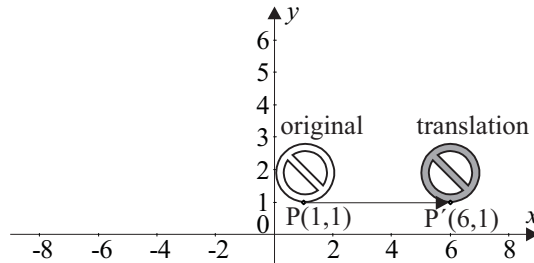

Translation is a movement in a given direction through a given distance. It can be horizontally, vertically or at any angle.

In the diagram above the figure is moved in a given direction ( $0^\circ$ ) through a given distance (5 units). So the point  $P(1, 1)$  becomes  $P'(6, 1)$ .

We could also depict this in matrix form. If we represent  $P$  as the position vector  $\begin{pmatrix} 1 \\ 1 \end{pmatrix}$  then what matrix would translate  $\begin{pmatrix} 1 \\ 1 \end{pmatrix}$  to  $\begin{pmatrix} 6 \\ 1 \end{pmatrix}$ . In this case we can add the matrix  $\begin{pmatrix} 5 \\ 0 \end{pmatrix}$ .

$$\begin{pmatrix} 1 \\ 1 \end{pmatrix} + \begin{pmatrix} 5 \\ 0 \end{pmatrix} = \begin{pmatrix} 6 \\ 1 \end{pmatrix}.$$

What would the translation matrix  $\begin{pmatrix} 3 \\ 4 \end{pmatrix}$  do to the point  $P$ ?

Using matrix addition we get  $\begin{pmatrix} 1 \\ 1 \end{pmatrix} + \begin{pmatrix} 3 \\ 4 \end{pmatrix} = \begin{pmatrix} 4 \\ 5 \end{pmatrix}$ .

**Figure 5.33:** Point P under translation by the matrix  $\begin{pmatrix} 3 \\ 4 \end{pmatrix}$

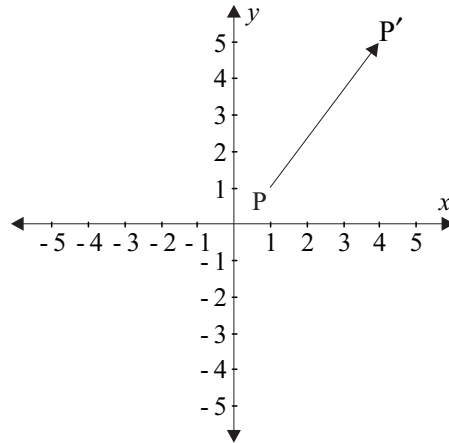

**Something to think about...**

The matrix  $\begin{pmatrix} 3 \\ 4 \end{pmatrix}$  can be thought of as a displacement vector. Why?

**Enlargement**

**Figure 5.34:** Shape enlarged by a factor of 2

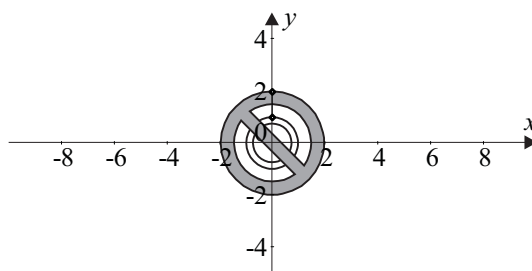

The figure above is enlarged by a factor of 2. The point  $(0, 1)$  becomes the point  $(0, 2)$ .

If we take the matrix  $\begin{pmatrix} 2 & 0 \\ 0 & 2 \end{pmatrix}$  and multiply it by  $\begin{pmatrix} 0 \\ 1 \end{pmatrix}$  then we get  $\begin{pmatrix} 2 & 0 \\ 0 & 2 \end{pmatrix} \begin{pmatrix} 0 \\ 1 \end{pmatrix} = \begin{pmatrix} 0 \\ 2 \end{pmatrix}$ .

If we wanted to enlarge it by a factor of 4 the matrix would be  $\begin{pmatrix} 4 & 0 \\ 0 & 4 \end{pmatrix}$ .

**Something to think about...**

Under dilation (i.e. enlargement), what happens if the figure is not centred about the origin?

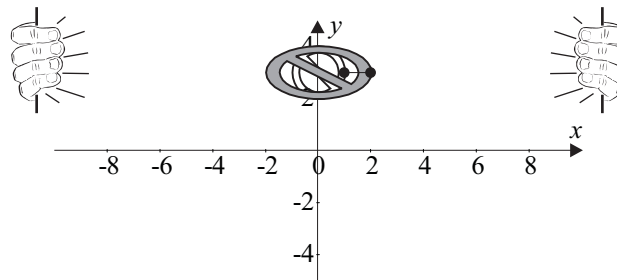
**Stretch****Figure 5.35:** Shape stretched horizontally by a factor of 2

Stretch is basically enlargement in one direction only. Think of the figure above on a piece of stretchy material. Grab the material at two ends and pull. The figure distorts in one direction.

In figure 5.35 above the shape is stretched in the horizontal direction by a factor of 2. The point (1, 1) becomes the point (2, 1).

If we shrink it by a factor of 4 then the point (2, 1) would become the point (0.5, 1).

Again, let's think of this in terms of the point P as the position vector  $\begin{pmatrix} 2 \\ 1 \end{pmatrix}$ . Again we can use matrix multiplication, but this time the y-coordinate does not change.

Can you guess what the matrix would be to stretch  $\begin{pmatrix} 2 \\ 1 \end{pmatrix}$  to become  $\begin{pmatrix} 4 \\ 1 \end{pmatrix}$

$$\begin{pmatrix} ? & ? \\ ? & ? \end{pmatrix} \begin{pmatrix} 2 \\ 1 \end{pmatrix} = \begin{pmatrix} 4 \\ 1 \end{pmatrix}?$$

If we wanted to shrink the figure in the horizontal direction then the matrix would be  $\begin{pmatrix} \frac{1}{4} & 0 \\ 0 & 1 \end{pmatrix}$ .

The new point would be  $\begin{pmatrix} \frac{1}{4} & 0 \\ 0 & 1 \end{pmatrix} \begin{pmatrix} 2 \\ 1 \end{pmatrix} = \begin{pmatrix} \frac{1}{4} \times 2 + 0 \times 1 \\ 0 \times 2 + 1 \times 1 \end{pmatrix} = \begin{pmatrix} 0.5 \\ 1 \end{pmatrix}$ .

**Something to think about...**

What happens when we stretch a shape vertically? Can you think of the  $2 \times 2$  matrix that would change the point  $\begin{pmatrix} 5 \\ 4 \end{pmatrix}$  to the point  $\begin{pmatrix} 5 \\ 8 \end{pmatrix}$  by a vertical stretch? We will address this stretching in activity 5.11.

**Example**

Write down the  $2 \times 2$  matrix that will transform  $\begin{pmatrix} 3 \\ 2 \end{pmatrix}$  to  $\begin{pmatrix} 3 \\ -2 \end{pmatrix}$ . Once you have found this, use the matrix to reflect the point  $(-2, 4)$  in the  $x$ -axis. Check your answer with a diagram.

We need to form a matrix equation in the form:  $\begin{pmatrix} - & - \\ - & - \end{pmatrix} \begin{pmatrix} 3 \\ 2 \end{pmatrix} = \begin{pmatrix} 3 \\ -2 \end{pmatrix}$ .

The  $2 \times 2$  matrix will be  $\begin{pmatrix} 1 & 0 \\ 0 & -1 \end{pmatrix}$ .

We can use this matrix to reflect the point  $(-2, 4)$  in the  $x$ -axis:

$$\begin{pmatrix} 1 & 0 \\ 0 & -1 \end{pmatrix} \begin{pmatrix} -2 \\ 4 \end{pmatrix} = \begin{pmatrix} -2 \\ -4 \end{pmatrix}$$

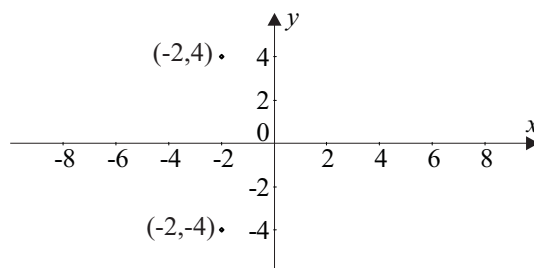

From the diagram, you can see the matrix  $\begin{pmatrix} 1 & 0 \\ 0 & -1 \end{pmatrix}$  reflects the point  $(-2, 4)$  in the  $x$ -axis on to the point  $(-2, -4)$ .

**Activity 5.11**

- Write down the  $2 \times 2$  matrix that will transform  $\begin{pmatrix} 1 \\ -3 \end{pmatrix}$  to  $\begin{pmatrix} -1 \\ -3 \end{pmatrix}$ .

- Use the matrix to reflect the point  $(-2, 4)$  in the  $y$ -axis. Check your answer with a diagram.
- Use matrix multiplication to reflect the point  $(30, 21)$  in the  $x$ -axis.
  - Under a reflection in the line  $y = x$ ,  $(1, -8)$  is transformed to  $(-8, 1)$ . Write down the  $2 \times 2$  matrix that reflects coordinates in the line  $y = x$ . What are the coordinates of the point  $(-3, -3)$  after reflection in the line  $y = x$ ?
  - The point  $(4, -5)$  is transformed to the point  $(5, -4)$  under reflection. Find the  $2 \times 2$  matrix and specify the transformation.
  - Reflect  $(3, 2)$  in the  $x$ -axis; then reflect its image in the line  $y = x$ . What are the coordinates of the final image?
  - Convert the point  $(5, -12)$  to its polar coordinates.
    - Hence, or otherwise, find the rectangular coordinates of  $(5, -12)$  after it has been rotated in an anti-clockwise direction through an angle of  $30^\circ$ .
    - Now rotate this image through a further angle of  $60^\circ$  writing the coordinates in rectangular form.
    - Check your answer to (c) by rotating the original point  $(5, -12)$  through an angle of  $90^\circ$ .

What this section illustrates is the geometric equivalent of the function work that you have been doing, especially in module 3. Recall that a function is a mapping from the domain onto the range. Here a transformation is a mapping of the original figure onto an image. For example, when we looked at functions in module 3, if we had a set of numbers  $\{1,2,3,4,5,6\}$  and applied the function ‘double each number’ we would be mapping onto another set  $\{2,4,6,8,10\}$ . If we took an infinite set of numbers, we could have seen this algebraically as  $f(x) = 2x$  and graphically as

**Figure 5.36:** Graph of  $f(x) = 2x$

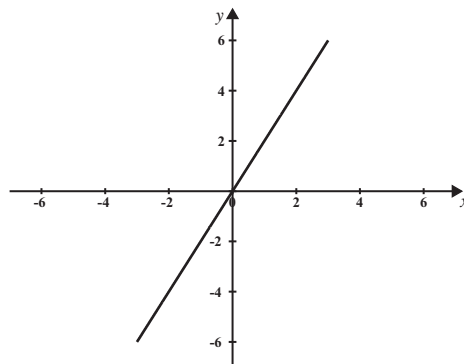

Similarly if we have a set of points  $\{(1, 1), (2, 2), (3, 3), (4, 4)\}$  and reflected these points in the  $y$ -axis i.e. mapped them onto another set  $\{(-1, 1), (-2, 2), (-3, 3), (-4, 4)\}$ . Graphically we could see it as in figure 5.37.

Figure 5.37: Graph of mapping

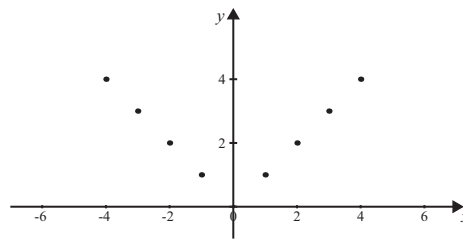

Let's look at all of these transformations in general terms. If we have a point  $(x, y)$  in the Cartesian coordinate system depicted by the position vector  $\begin{pmatrix} x \\ y \end{pmatrix}$  then by multiplying it by the matrices below we can find a new point under the particular transformation. (You **do not** have to remember these transformations.) We will return to this when we look at transforming lines.

Transformation	Coordinate change	Matrix transformation
reflection in the $y$ -axis	$(x, y) \rightarrow (-x, y)$	$\begin{pmatrix} -1 & 0 \\ 0 & 1 \end{pmatrix} \begin{pmatrix} x \\ y \end{pmatrix} = \begin{pmatrix} -x \\ y \end{pmatrix}$
reflection in the $x$ -axis	$(x, y) \rightarrow (x, -y)$	$\begin{pmatrix} 1 & 0 \\ 0 & -1 \end{pmatrix} \begin{pmatrix} x \\ y \end{pmatrix} = \begin{pmatrix} x \\ -y \end{pmatrix}$
reflection in the line $y = x$	$(x, y) \rightarrow (y, x)$	$\begin{pmatrix} 0 & 1 \\ 1 & 0 \end{pmatrix} \begin{pmatrix} x \\ y \end{pmatrix} = \begin{pmatrix} y \\ x \end{pmatrix}$
rotation of $\theta$ degrees in an anticlockwise direction	$(r, \alpha) \rightarrow (r, \alpha + \theta)$ (where $x = r \cos \alpha, y = r \sin \alpha$ so, new point is $(r \cos(\alpha + \theta), r \sin(\alpha + \theta))$ )	$\begin{pmatrix} \cos \theta & -\sin \theta \\ \sin \theta & \cos \theta \end{pmatrix} \begin{pmatrix} x \\ y \end{pmatrix}$ $= \begin{pmatrix} x \cos \theta - y \sin \theta \\ x \sin \theta + y \cos \theta \end{pmatrix}$
enlargement by a factor of $k$	$(x, y) \rightarrow (kx, ky)$	$\begin{pmatrix} k & 0 \\ 0 & k \end{pmatrix} \begin{pmatrix} x \\ y \end{pmatrix} = \begin{pmatrix} kx \\ ky \end{pmatrix}$
stretch horizontally by a factor of $k$	$(x, y) \rightarrow (kx, y)$	$\begin{pmatrix} k & 0 \\ 0 & 1 \end{pmatrix} \begin{pmatrix} x \\ y \end{pmatrix} = \begin{pmatrix} kx \\ y \end{pmatrix}$
stretch vertically by a factor of $k$	$(x, y) \rightarrow (x, ky)$	$\begin{pmatrix} 1 & 0 \\ 0 & k \end{pmatrix} \begin{pmatrix} x \\ y \end{pmatrix} = \begin{pmatrix} x \\ ky \end{pmatrix}$
translate the point $a$ units horizontally and $b$ units vertically	$(x, y) \rightarrow (x+a, y+b)$	$\begin{pmatrix} x \\ y \end{pmatrix} + \begin{pmatrix} a \\ b \end{pmatrix} = \begin{pmatrix} x+a \\ y+b \end{pmatrix}$

## 5.4.2 Transforming straight lines

How can we use this idea of transformations more explicitly in lines and curves? You have already had practice with some of these transformations in module 3 and module 4, although we didn't use the term transformation. We will now look at them in more general terms. If we take the line  $y = x$  we can actually transform this into any other line we want by using the tools from the table in the previous section. We can use matrices, but we could also use algebra. As you do more mathematics you may find the matrix method more appropriate at times. In fact if you continue to study mathematics at university you may discover how to transform any line into any other shape (using projective geometry) a bit like the 'morphisms' in computer graphics or the special effects in the movies!

While it would be possible to extend your knowledge of matrices for lines and curves, we will leave this for another unit, but you may work on this yourself! In the following section we will see how the transformations are applied algebraically.

The examples below show transformation of an original straight-line equation to a new straight-line equation. In this section you may like to photocopy or duplicate these sheets of paper on to tracing paper and physically cut or fold the paper to simulate the particular transformation (or just use your imagination if you have good visual skills). In the reflections, translations and stretching we will give general rules, but for rotations – just something to think about.

We also want you to consider the points highlighted in module 3 when investigating functions i.e.,

- What will be the shape of the new graph?
- Where will it cut the vertical axis?
- Where will it cut the horizontal axis?
- What is the rate of change of the dependent variable with respect to the independent variable?
- Is it a continuous function?
- Do you think it will have an inverse function?

### Reflection

Look at the function in  $f(x) = -2x - 4$  figure 5.37. If we reflect it in the  $y$ -axis, then what is the new function?

**Figure 5.38:** Graph of  $f(x) = -2x - 4$  and its reflection in the  $y$ -axis

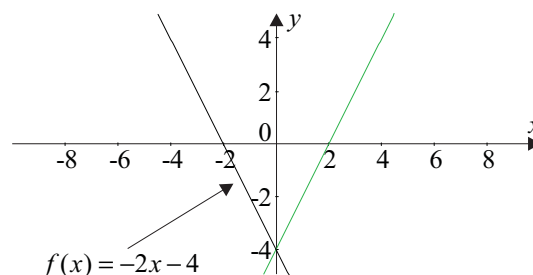

Comparing both lines, for each point, the  $x$ -coordinate changes sign but the  $y$ -coordinate stays the same. The  $y$ -intercepts are the same. The gradients have the same magnitude but a different sign. It is still a continuous function and it will have an inverse.

Can you see it becomes  $g(x) = 2x - 4$ ? Try plotting some points to confirm this.

Do this reflection for a few other functions. What happens to:

$$f_1(x) = 7x + 2$$

$$f_2(x) = -x - 4$$

$$f_3(x) = 9x - 8$$

Sketch them (or use Graphmatica) then reflect them in the  $y$ -axis. (You may like to fold the paper along the  $y$ -axis.) Can you see they now become respectively:

$$g_1(x) = -7x + 2$$

$$g_2(x) = x - 4$$

$$g_3(x) = -9x - 8$$

Now we want to generalise this process. If we had a function  $f(x) = mx + c$ , what is the equation of the new function if we reflected it in the  $y$ -axis?

We could have said  $g(x) = -mx + c$ , but there is another general function that would also work, and is more useful when we look at further curves. The new function can be created by replacing the  $x$  with  $-x$  so with our function from figure 5.37:

$$\begin{aligned} f(-x) &= -2(-x) - 4 \\ &= 2x - 4 \\ &= g(x) \end{aligned}$$

If you are unsure about this step, revise the section on functional notation in module 3.2.1.

### **In general for reflection in the $y$ -axis**

$$g(x) = f(-x)$$

Now reflect the following in the  $x$ -axis:

$$f_1(x) = 7x + 2 \text{ (see figure 5.38)}$$

$$f_2(x) = -x - 4$$

$$f_3(x) = 9x - 8$$

You should be able to find a general statement for reflection in the  $x$ -axis.

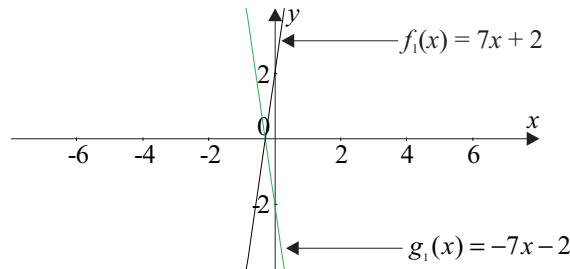
**Figure 5.39:** Graph of  $f_1(x) = 7x + 2$  and its reflection  $g_1(x) = -7x - 2$  in the  $x$ -axis

Can you see the new equations are the negative of the old equations?

$$f_1(x) = 7x + 2 \Rightarrow g_1(x) = -7x - 2$$

$$f_2(x) = -x - 4 \Rightarrow g_2(x) = x + 4$$

$$f_3(x) = 9x - 8 \Rightarrow g_3(x) = -9x + 8$$

**So in general, for reflection in the  $x$ -axis**

$$g(x) = -f(x)$$

What happens when the line is reflected in the line  $y = x$ ? (Recall the section on inverses in module 3.2.5.)

Can you see the general statement is  $g(x) = f^{-1}(x)$

## Rotation

This is more difficult to do, and you need more understanding of matrices, in order to do this easily. What we expect you to do here is think about what the new line will look like and be able to sketch it. At this level you are not expected to use matrices to find a new equation.

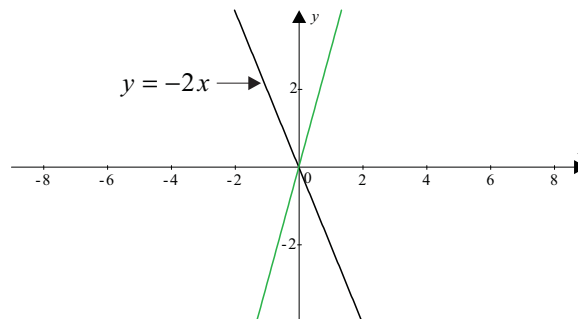
**Figure 5.40:** Graph of  $y = -2x$  and its rotation of  $45^\circ$  clockwise about the origin

If we rotate  $y = -2x$  clockwise about the origin through an angle of  $45^\circ$  then the graph looks about  $y \approx 3x$ . (see figure 5.39). Here the intercept remains the same but the gradient changes.  $y = -2x$  makes an angle of  $117^\circ$  ( $\tan 117^\circ \approx -2$ ). So if we move  $45^\circ$  in a clockwise direction, the angle is now  $72^\circ$ . The gradient is now 3 since  $\tan 72^\circ \approx 3$ .

What if the line was rotated about a different point on the line (e.g.  $(-4, 8)$ ) or off the line e.g., about the point  $(1, 1)$  as shown in figure 5.41?

**Figure 5.41:** Graph of  $f(x) = -2x$  and its rotation of  $90^\circ$  clockwise about the point  $(1, 1)$

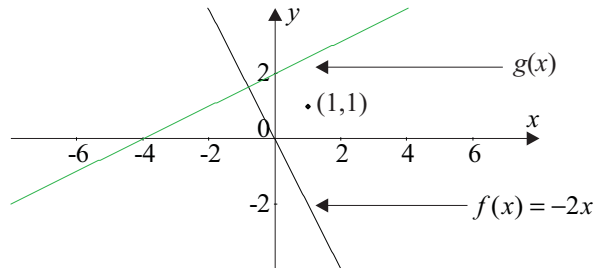

You may like to sketch some other scenarios by hand to get a feel for the effect of the size of the rotation and the centre of the rotation.

## Translation

Here we will just look at line segments as they give a clearer indication of the translation involved.

**Figure 5.42:** Graph of  $f(x) = 2x$  and its translation 1 unit horizontally to the right

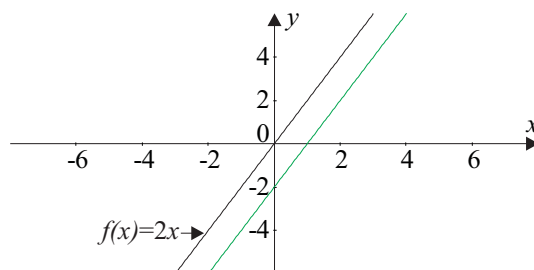

Look at figure 5.42. Here the line segment  $f(x) = 2x$  is moved through a distance of 1 unit horizontally to the right. Most of the features of the new line are the same as the old line (including the gradient), but the  $y$ -intercept moves to  $-2$ , so the new equation is:

$$g(x) = 2x - 2$$

Do this for a few other functions. What happens to:

$$f_1(x) = 7x + 2 \text{ if it is moved 3 units to the right}$$

$$f_2(x) = -x - 4 \text{ if it is moved 1 unit to the left}$$

$$f_3(x) = 9x - 8 \text{ if it is moved 5 units to the right}$$

Can you see they now become respectively:

$$g_1(x) = 7(x - 3) + 2 = 7x - 19$$

$$g_2(x) = -(x + 1) - 4 = -x - 5$$

$$g_3(x) = 9(x - 5) - 8 = 9x - 53$$

In the above equations, each value of  $x$  has been changed by adding or subtracting a number of units.

**In general if we translate a line  $a$  units horizontally then the new function becomes  $g(x) = f(x - a)$ .**

### Something to think about...

What happens if the line segment is translated vertically? Can you find a general statement about translating a function vertically? We will address this translation in activity 5.12.

### Stretch

Figure 5.43 shows the function  $f(x) = 2x + 1$ . If we stretch it in the horizontal direction by a factor of 2, then what happens to the new function? The  $y$ -coordinate stays the same. The  $x$ -intercept is doubled. The gradient has become much less steep. In fact it has halved. Can you see the new function becomes  $g(x) = x + 1$ ?

**Figure 5.43:** Graph of  $f(x) = 2x + 1$  and its stretch horizontally by a factor of 2

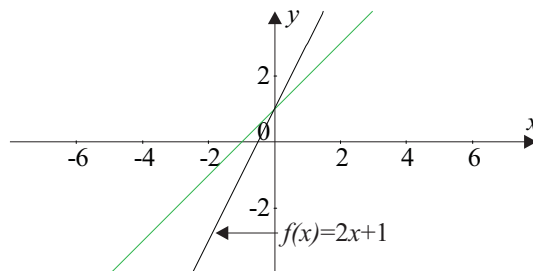

Do this for a few other functions. What happens to:

$$f_1(x) = 7x + 2 \text{ if it is stretched by a factor of 3 units}$$

$$f_2(x) = -x - 4 \text{ if it is stretched by a factor of 4 units}$$

$$f_3(x) = 9x - 8 \text{ if it is compressed by a factor of 5 units}$$

Can you see they now become respectively:

$$g_1(x) = 7\left(\frac{x}{3}\right) + 2 = \frac{7x}{3} + 2$$

$$g_2(x) = -\left(\frac{x}{4}\right) - 4$$

$$g_3(x) = 9(5x) - 8 = 45x - 8$$

So in general, if we stretch a line  $n$  times horizontally then  $g(x) = f\left(\frac{x}{n}\right)$

**Something to think about...**

Can you create a general statement when we stretch a function vertically?

In the stretches we have talked about, the centre of the stretch is along the axes, so the point on the  $y$ -axis in a horizontal stretch does not move. Can you see what happens when we may want to stretch but take the centre from another axis – say the line  $x = 2$  as in figure 5.44?

We will address these stretch questions in activity 5.12.

**Figure 5.44:** Graph of  $y = 4x - 4$

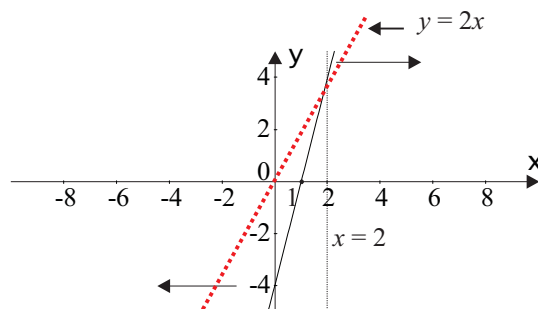

When the function is stretched horizontally the point  $(2, 4)$  remains the same but the gradient halves, so the new line will be  $y = 2x + c$ . If we substitute  $(2, 4)$  into the equation, we see  $c = 0$ , so the equation will be  $y = 2x$ .

## Activity 5.12

- Sketch the graph of  $f(x) = -x + 2$  and  $g(x)$ , its rotation of  $180^\circ$  about the origin, clearly marking all  $x$ - and  $y$ -intercepts.
- Sketch the graph  $f(x) = 2x + 1$  and  $g(x)$  its translation if it is moved one unit to the right and write the function  $g(x)$ .
  - If  $h(x)$  is the vertical translation of  $f(x)$  when it is moved down two units, sketch its graph and write its function.
- Consider the function  $f(x) = x - 3$ .
  - If  $f(x)$  is stretched horizontally by a factor of 2 to become  $g(x)$ ,
    - Sketch both  $f(x)$  and  $g(x)$ .
    - Write the function  $g(x)$ .
  - If  $f(x)$  is stretched vertically along the  $y$ -axis by a factor of 3 to become  $h(x)$ , write  $h(x)$ .
  - If  $f(x)$  is stretched horizontally by a factor of 2 with the centre as the line  $x = 1$ , what is the new function?

Let's have a look at the transformations of straight lines in general in relation to our points we did in the previous section. If we had a function  $f(x)$  with a point on the line  $(x, y)$ , what happens to the point and the line under the transformations below.

Transformation	Coordinate change	Functional change
reflection in the $y$ -axis	$(x, y) \rightarrow (-x, y)$	$g(x) = f(-x)$
reflection in the $x$ -axis	$(x, y) \rightarrow (x, -y)$	$g(x) = -f(x)$
reflection on the line $y = x$	$(x, y) \rightarrow (y, x)$	$g(x) = f^{-1}(x)$
stretch horizontally by a factor of $k$	$(x, y) \rightarrow (kx, y)$	$g(x) = f\left(\frac{x}{k}\right)$
stretch vertically by a factor of $k$	$(x, y) \rightarrow (x, ky)$	$g(x) = k \times f(x)$
translation $a$ units horizontally and $b$ units vertically	$(x, y) \rightarrow (x+a, y+b)$	$g(x) = f(x-a) + b$

### 5.4.3 Transforming parabolas

Exactly the same method can be used in transforming parabolas. Look at the transformations below and see how the generalisations in the previous table apply here.

#### Reflection

**Figure 5.45:** Graph of  $f(x) = 3x^2 - 12x + 8$  and its reflection in the  $y$ -axis

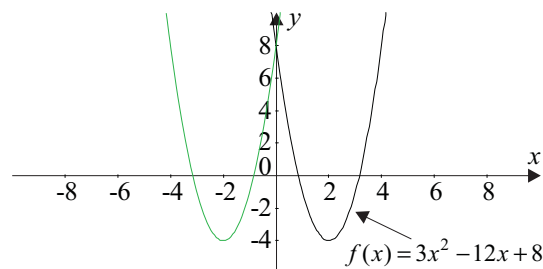

Figure 5.44 shows the function  $f(x) = 3x^2 - 12x + 8$ . If we reflect it in the  $y$ -axis it becomes  $g(x) = 3x^2 + 12x + 8$ .

The basic shape is the same, the  $y$ -intercepts will be the same; the  $y$ -coordinate of the minimum will be the same; the  $x$ -coordinate will be the same magnitude but a different sign. The average rate of change will be different. For example for the function  $f(x)$  between  $x = 1$  and  $2$  we can see the gradient falling. This is the same average rate of change for  $g(x)$  for  $x$  between  $-1$  and  $-2$  except it is positive.

How can we predict the equation to this new curve? Consider the statement that reflection in the  $y$ -axis produces a new function  $g(x) = f(-x)$ . Does this work for parabolas?

$$\begin{aligned} f(-x) &= 3(-x)^2 - 12(-x) + 8 \\ &= 3x^2 + 12x + 8 \end{aligned}$$

Try a few more yourself in Graphmatica to convince yourself that it works.

#### Something to think about...

What happens when it is reflected in the  $x$ -axis? Check to see the general statement  $g(x) = -f(x)$  works in this case.

What if the parabola was reflected in the line  $y = x$ ? Check to see the general statement:  $g(x) = f^{-1}(x)$  works. (You may like to check this using Graphmatica as well as folding along the line  $y = x$ ). Be careful! We cannot call the new equation  $g(x)$  since it is not a function.

## Rotation

Figure 5.45 shows the function  $f(x) = x^2$  being rotated anticlockwise about the origin through an angle of  $90^\circ$ .

**Figure 5.46:** Graph of  $f(x) = x^2$  and its rotation  $90^\circ$  anticlockwise.

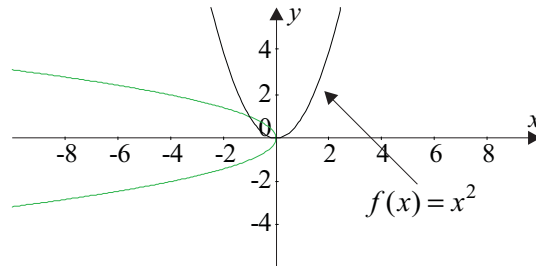

The  $x$  and  $y$  values are now swapped and the domain is only negative values of  $x$ . The new parabola, however is not a function, but if we let  $y = f(x)$  then the new equation is  $-y^2 = x$ . Can you see this is exactly the same as reflecting the parabola in the line  $y = -x$ ?

### Something to think about...

What happens when it is rotated  $180^\circ$ ?

What if the parabola was rotated about a different point (e.g. the point  $(0,5)$ )? Can you sketch this new curve? If you think about it as first rotating  $f(x) = x^2$  as above then translating it so the point  $(0, 0)$  becomes the point  $(5, 5)$ , as in figure 5.46. Can you guess the equation of this new curve?

**Figure 5.47:** Graph of  $f(x) = x^2$  after it has been rotated  $90^\circ$  anticlockwise about the point  $(0, 5)$

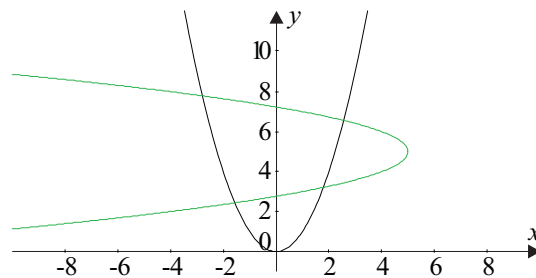

## Translation

Figure 5.46 shows a translation of the function  $f(x) = x^2 + 2x + 2$ , 5 units to the left.

**Figure 5.48:** Graph of  $f(x) = x^2 + 2x + 2$  and its translation 5 units to the left

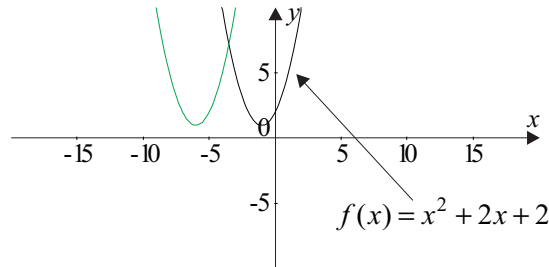

The new function has the same basic shape as the previous one but the  $y$ -intercept will be much further up the  $y$ -axis. In the previous section we said that if we moved a line  $a$  units then each  $x$  value is moved  $a$  units,  $g(x) = f(x - a)$ . In this case we are moving 5 units to the left so  $a = -5$ . Therefore we must add 5 to each  $x$  value i.e.

$$\begin{aligned} y &= (x + 5)^2 + 2(x + 5) + 2 \\ &= x^2 + 10x + 25 + 2x + 10 + 2 \\ &= x^2 + 12x + 37 \end{aligned}$$

Check this by drawing both graphs on Graphmatica.

The statement **in general if we translate a line  $a$  units horizontally then the new function becomes  $g(x) = f(x - a)$** , holds true for parabolas as well.

Try some more translations and draw them on Graphmatica to convince yourself that it works.

### Something to think about...

What happens if we translate it vertically? In the translation in figure 5.47, could you see the transformation in terms of a reflection in a vertical line (not the  $y$ -axis)?

## Stretch

Figure 5.48 shows the parabola  $f(x) = 4x^2 + 2$ . It is stretched by a factor of 2.

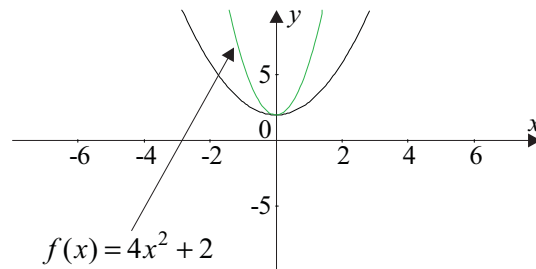
**Figure 5.49:** Graph of  $f(x) = 4x^2 + 2$  and its stretch by a factor of 2

The new parabola is still a function. Here the shape of the parabola has changed; the  $y$ -intercept is the same; the average rate of change for the new graph will be much less for the same  $x$  intervals.

Does the general statement from the previous section i.e., that if a line is stretched horizontally then  $g(x) = f\left(\frac{x}{n}\right)$  apply here? In this case  $n = 2$ . So the new function is:

$$\begin{aligned} g(x) &= 4\left(\frac{x}{2}\right)^2 + 2 \\ &= x^2 + 2 \end{aligned}$$

Check this on Graphmatica and try a few more examples.

The statement: **in general, if we stretch a line  $n$  times horizontally then  $g(x) = f\left(\frac{x}{n}\right)$  holds true for parabolas as well.**

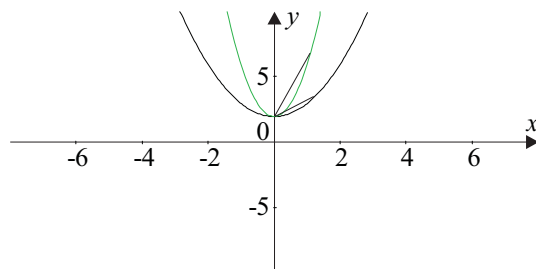
**Figure 5.50:** Comparison of average rates of change for  $f(x) = 4x^2 + 2$  and  $f(x) = x^2 + 2$ 

Ask yourself: What happens to the average rate of change? Let's take the change from  $(0, 2)$  to  $(1, 6)$ . The rate of change is  $\frac{6-2}{1-0} = 4$ .

In the new function, the rate of change for the same  $x$ -interval is 1 (a quarter of the original) since the coordinates are now  $(0, 2)$  and  $(1, 3)$ . In figure 5.48 you can see the second line is much less steep than the first line. Is this a bit unexpected?

Try taking other points to see if the rate of change for the new function is a quarter of the old function. In the next module you will discover why this is the case.

**Something to think about...**

What happens if you stretch parabolas vertically?

### Activity 5.13

---

1. Consider the function  $f(x) = 2x^2 + 3x - 2$ .
  - (i) Sketch  $f(x)$  and its reflection in the  $y$ -axis.
  - (ii) Write the equation for the reflection.
  - (iii) Is it a function?
  - (iv) Reflect  $f(x)$  in the  $x$ -axis.
  - (v) Sketch its graph and write its equation.
  - (vi) Is this reflection a function?
  - (vii) The graph of  $f(x)$  could have been rotated through  $180^\circ$  to obtain the reflected graph above. About which point would  $f(x)$  have to be rotated?
2. (a) Consider the function  $f(x) = x^2$ .
  - (i) Sketch the parabola  $y = x^2$ .
  - (ii) Rotate the parabola about the origin in an anticlockwise direction through  $90^\circ$  and sketch its graph.
  - (iii) What is its equation? Is this a function?
  - (iv) On the same axes as above, sketch the rotation if  $y = x^2$  had been rotated about the point  $(0, -1)$ .
  - (v) What is the equation of this rotation?(b) What is the equation of the rotated curve in figure 5.46?
3. Consider the function  $f(x) = -3x^2 - 1$ 
  - (i) Find  $g_1(x)$  which represents  $f(x)$  stretched horizontally by factor 2.
  - (ii) Which curve is steeper for corresponding values of  $x$ ?
  - (iii) Now stretch  $f(x)$  vertically by factor 2 to obtain  $g_2(x)$ .
  - (iv) Which function  $f(x)$ ,  $g_1(x)$  or  $g_2(x)$  is the steepest?

## 5.4.4 Transforming other curves

In this section you will see how the transformations apply to the functions you have studied in modules 3 and 4 i.e., exponential, logarithmic and trigonometric curves. However, we will also look at a few specific transformations of interest.

### Reflection of the exponential curve

Recall in module 3 (3.3.2) the exponential and logarithmic functions are inverses of each other.

Reflection of  $y = e^x$  in the line  $y = x$  produces the line  $y = \ln x$  as seen in figure 5.49.

**Figure 5.51:** Graph of  $y = e^x$  and its reflection in the line  $y = x$

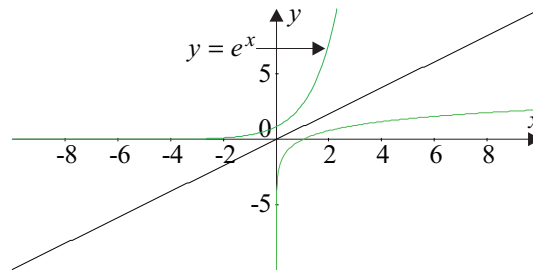

When you reflect a curve in the line  $y = x$ , the values of  $y$  and  $x$  swap so  $y = e^x$ . Make  $y$  the subject of the formula and we get  $y = \ln x$ .

But if we reflect the exponential and logarithmic curves in the  $x$  and  $y$ -axes – what are the new equations?

For the exponential curves, you should get  $y = e^{-x}$  and  $y = -e^x$  for the reflections in the  $y$  and  $x$ -axes respectively, and you should get  $y = \ln(-x)$  and  $y = -\ln x$  for similar reflections for the log curves. Sketch these by hand on figure 5.50 and use Graphmatica to confirm your sketches. Note with each of these reflections the changes in domain and range of the functions. For example in the graph of  $y = \ln(-x)$  the domain is  $-\infty < x < 0$ . So you will always be finding the log of a positive number!

**Example**

If the function  $f(x)$  below represents  $f(x) = e^x$ , what is the equation of the new function  $g(x)$  under translation?

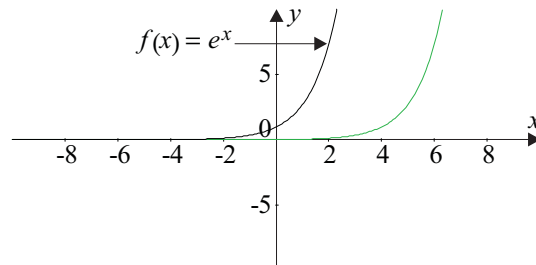

The function has moved 2 units to the right so  $g(x) = e^{x-2}$ .

**Example**

If the function  $f(x)$  below represents  $f(x) = \sin x$ , what is the new function  $g(x)$  under a reflection?

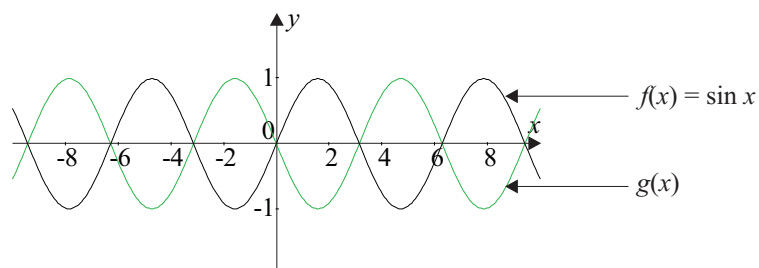

We can consider this as a reflection either in the  $x$ - or  $y$ -axis.

The new function will be:

$$g(x) = -\sin x \text{ or}$$

$$g(x) = \sin(-x)$$

Can you see these represent the same function?

**Example**

If the function  $f(x)$  below represents  $f(x) = \sin x$ , what is the new function  $g(x)$  under horizontal stretch? Comment on the average rate of change of the two functions.

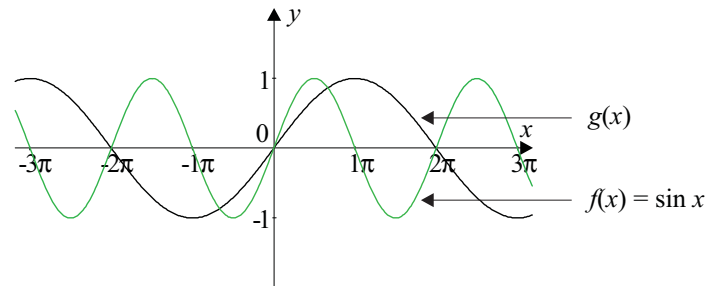

$g(x)$  has been stretched by a factor of 2, so the new function will be  $g(x) = \sin\left(\frac{x}{2}\right)$ .

$f(x)$  is changing much more slowly than  $g(x)$  for any value of  $x$ .

**Example**

If the function  $f(x)$  below represents  $f(x) = \frac{1}{x}$ , what is the new function  $g(x)$  and how did this new function get transformed?

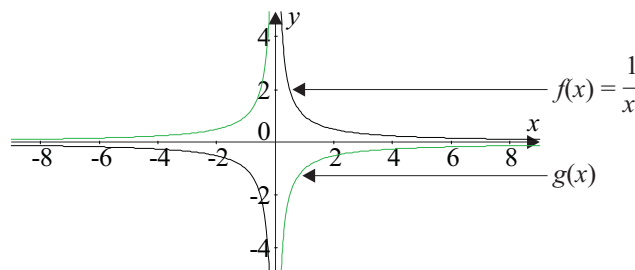

The new function was reflected in the  $y$ - or  $x$ -axis, or was rotated  $90^\circ$  either clockwise or anticlockwise. The new function will be  $g(x) = -\frac{1}{x}$ .

## Activity 5.14

1. Consider the function  $f(x) = e^x$ 
  - (i) Translate  $f(x) = e^x$  up two units, sketching both graphs.
  - (ii) Write the equation of the new function.
  - (iii) The point  $(0, 1)$  is translated to which point?
  - (iv) Translate  $f(x)$  one unit to the left, sketching its graph and writing its function.
  - (v) The point  $(0, 1)$  has been translated to which point by this last transformation?
2. The function  $f(x) = e^x$  is drawn below.
  - (a) What is the new function  $g(x)$  under horizontal stretch?

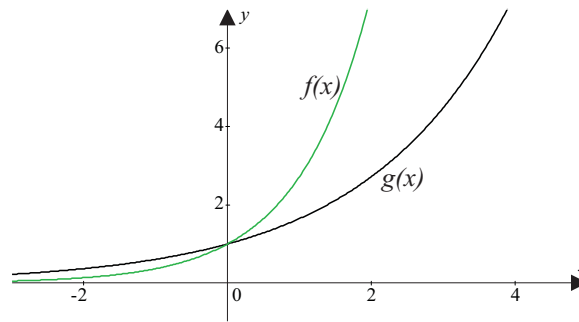

- (b) Under vertical stretch  $f(x) = \ln x$  is transformed to  $h(x)$ . What is the equation  $h(x)$ ? (Assume to stretch factor is a whole number.)

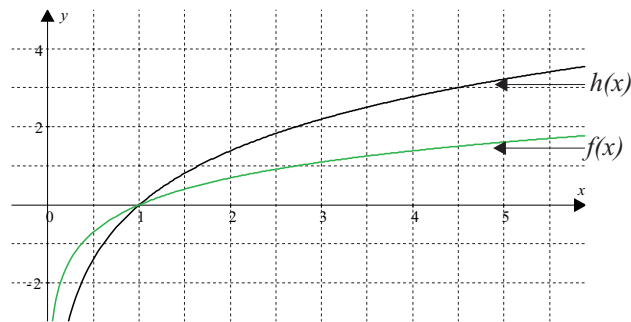

3. Below is the graph of  $f(x) = \cos x$  and the graph of  $g(x)$  which represents a translation of  $f(x)$ .

What is the new function  $g(x)$ ?

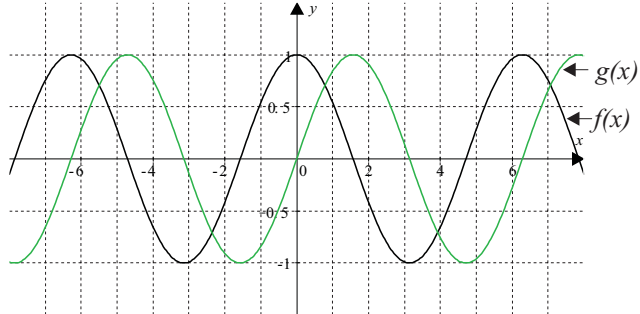

4. The graph of  $f(x) = \cos x$  and the graph of  $g(x)$  representing a horizontal stretch of  $f(x)$  are shown below.

$h(x)$  is the graph of a vertical stretch of  $f(x)$ . Write the equations of  $g(x)$  and  $h(x)$ .

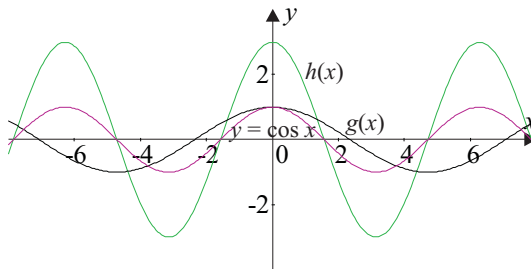

5. Consider the function  $f(x) = \frac{1}{x}$ .
- (i) Sketch  $f(x) = \frac{1}{x}$ .
  - (ii) What happens if we reflect  $f(x)$  in the line  $y = -x$ ?
  - (iii) Sketch  $g(x)$ , the graph when  $f(x)$  is translated two units to the right and one unit vertically upwards.
  - (iv) What is the equation for  $g(x)$ ?
  - (v) What are the new asymptotes?

## 5.4.5 Transforming circles

As you have not dealt with circles in any great depth to date, we will look at circles separately. Transforming circles is an important tool to add to your mathematical toolbox and it introduces you to a new curve, the ellipse. These shapes are useful in the study of astronomy (with orbits of satellites, planets etc.), in the study of motion of many objects e.g. pendulums and engines.

So far we have looked at circles with centres at the origin. These circles will be unchanged by both reflection about the  $x$  and  $y$ -axes and rotation about the origin. So let's start by looking at translating the circle.

### Translation

**Figure 5.52:** Graph of  $x^2 + y^2 = 4$  and its translation 4 units to the right

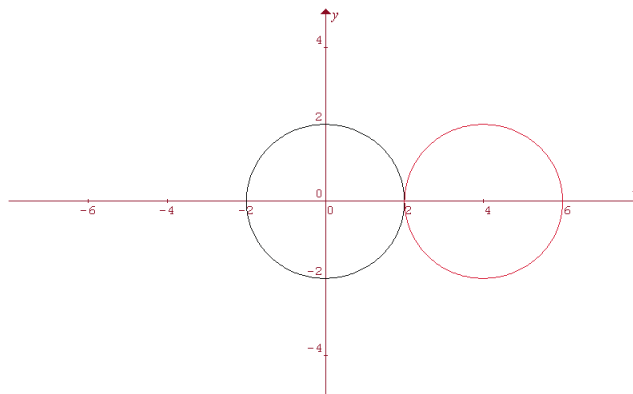

If we translate  $x^2 + y^2 = 4$ , 4 units to the right horizontally, we produce the new circle. The shape and radius of the circle remain unchanged. Take the average rates of change at any two points on the circle. The new function will have exactly the same average rate of change except the  $x$ -values of the two points will be 4 units larger.

Each value of  $x$  has been moved 4 units to the right. The new centre of the circle becomes  $(4, 0)$ . The equation to the circle is not a function, but the pattern is still the same – subtract 4 from each value of  $x$  and we get the new equation:

$$(x - 4)^2 + y^2 = 4$$

If we translate it 4 units vertically, then the equation becomes  $x^2 + (y - 4)^2 = 4$ , and the new centre of the circle becomes  $(0, 4)$ .

Now if we move it  $h$  units horizontally and  $k$  units vertically, then the new circle becomes  $(x - h)^2 + (y - k)^2 = r^2$ , and the new centre of the circle becomes  $(h, k)$ .

Practise drawing circles by hand and using Graphmatica changing the centre and the radius.

## Enlargement

**Figure 5.53:** Graph of  $x^2 + y^2 = 25$  and its enlargement by a factor of 2

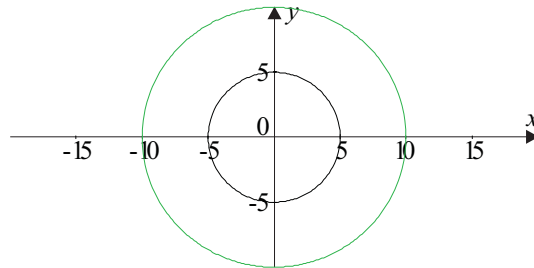

If we enlarge the circle  $x^2 + y^2 = 25$  we do not change its centre, only the radius. So if we enlarge it by a factor of 2, then the new circle has different  $x$  and  $y$ -intercepts. Instead of the radius being 5 it is now 10.

Can you see that the new curve will be:  $x^2 + y^2 = 100$ ?

What is happening to the rate of change at different points? Let's just draw some lines and compare the gradients of the circles  $x^2 + y^2 = 1$  and  $x^2 + y^2 = 4$ .

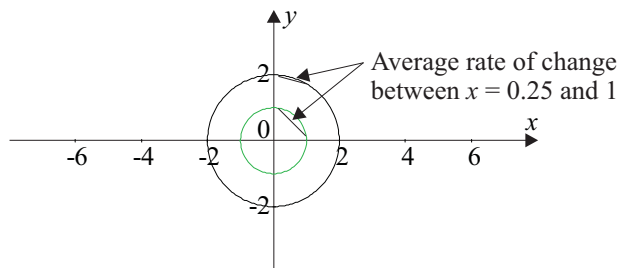

For the unit circle, the average rate of change is about 1.29 and for the other circle it is much smaller, at about 0.34.

## Stretch

Stretching in one direction produces an interesting shape. Enlargement of  $x^2 + y^2 = 1$  in the horizontal direction by a factor of 2 produces a figure, called an **ellipse**.

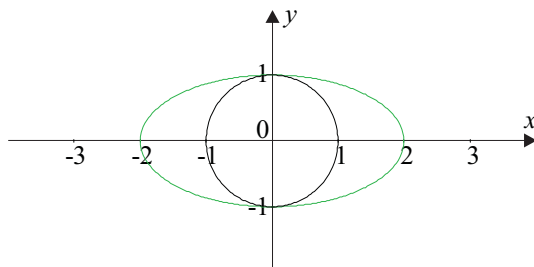
**Figure 5.54:** Graph of  $x^2 + y^2 = 1$  and its horizontal stretch by a factor of 2

The  $y$ -intercepts remain the same but the  $x$ -intercepts double, and the average rate of change is much slower for the ellipse.

Recall our pattern for stretching the lines and curves was  $g(x) = f\left(\frac{x}{n}\right)$ . Now this is not a function but the pattern is the same. The equation for this ellipse, which is stretched horizontally from the circle by a factor of 2, is  $\left(\frac{x}{2}\right)^2 + y^2 = 1$ .

What would happen if we stretched a circle vertically?

The equation to the ellipse formed when stretching the circle  $x^2 + y^2 = 4$  vertically by a factor of 4 becomes  $x^2 + \left(\frac{y}{4}\right)^2 = 4$  and the ellipse is drawn in figure 5.55.

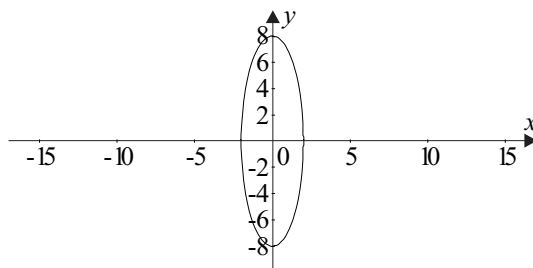
**Figure 5.55:** Graph of  $x^2 + \left(\frac{y}{4}\right)^2 = 4$ 

We often express the equation to this ellipse as  $\left(\frac{x}{2}\right)^2 + \left(\frac{y}{8}\right)^2 = 1$  (i.e., dividing the equation by 4). Can you see why this may be a more appropriate form in some circumstances? Do you notice that it gives the  $x$  and  $y$ -intercepts in the denominators of the fractions?

What if we stretched the unit circle by a factor of 4 units horizontally and a factor of 3 units vertically? We would then get the equation  $\left(\frac{x}{4}\right)^2 + \left(\frac{y}{3}\right)^2 = 1$ . The graph of this ellipse is shown in figure 5.56.

**Figure 5.56:** Graphs of  $x^2 + y^2 = 1$  and  $\left(\frac{x}{4}\right)^2 + \left(\frac{y}{3}\right)^2 = 1$

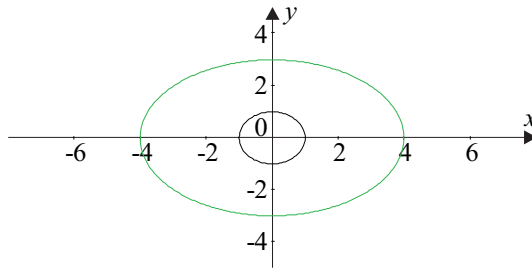

Notice the  $x$ -intercepts are  $(-4, 0)$  and  $(4, 0)$  and the  $y$ -intercepts are  $(0, 3)$  and  $(0, -3)$ .

In this ellipse the line from  $(-4, 0)$  to  $(4, 0)$  is called the **major axis**. These points are called the vertices of the ellipse. The line from  $(0, 3)$  to  $(0, -3)$  is called the **minor axis**.

The general equation of an ellipse with a centre at the origin is where  $(-a, 0)$  and  $(a, 0)$  are the  $x$ -intercepts and  $(0, b)$  and  $(0, -b)$  are the  $y$ -intercepts.

Remember another way to depict the circle? This was through the parametric equations:

$$x = r \cos \theta \text{ and } y = r \sin \theta$$

In the case of the unit circle in figure 5.56, where the radius is 1, the equations become:

$$x = \cos \theta \text{ and}$$

$$y = \sin \theta$$

In the case of the ellipse in figure 5.56, the  $x$ -coordinate of any point on the circle has been multiplied by 4, and each  $y$ -coordinate has been multiplied by 3. So parametrically the new equation becomes  $x = 4 \cos \theta$  and  $y = 3 \sin \theta$  (see figure 5.57).

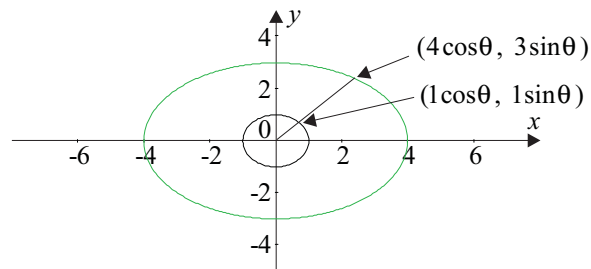
**Figure 5.57:** Graph of circle and ellipse with points expressed parametrically

Try practising drawing ellipses by hand and check them using Graphmatica. Use both the ordinary and parametric version of the equations.

### 5.4.6 rotating hyperbolae

We will look at one final interesting transformation in this unit, and that is rotating rectangular hyperbolae.

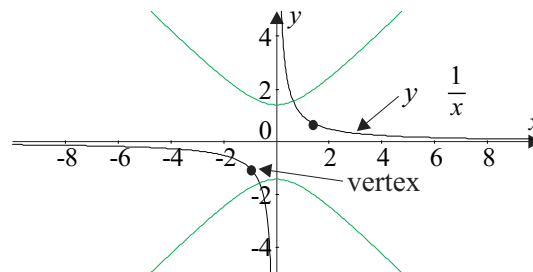
**Figure 5.58:** Graph of  $y = \frac{1}{x}$  and its rotation  $45^\circ$  anticlockwise

Rotation of  $y = \frac{1}{x}$  about the origin through an angle of  $45^\circ$  creates a new hyperbola.

In figure 5.58 the hyperbola is now symmetric about the  $x$  and the  $y$ -axes. The vertices are the  $y$ -intercepts  $(0, \sqrt{2})$  and  $(0, -\sqrt{2})$  and the two 'arms' of the hyperbola are equidistant from the origin.

Similarly rotation of  $y = \frac{1}{x}$  about the origin through an angle of  $-45^\circ$  (i.e., clockwise), creates another hyperbola as seen in figure 5.59.

This time the vertices are the  $x$ -intercepts  $(\sqrt{2}, 0)$  and  $(-\sqrt{2}, 0)$ .

**Figure 5.59:** Graph of Hyperbola after it has been Rotated 45° Clockwise

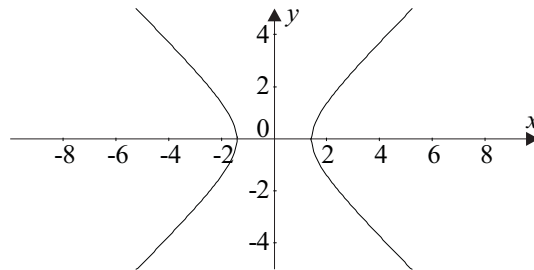

These hyperbolae have many applications, for example they can be used in navigation systems (LORAN – LOnG RAnge Navigation). Many comets have hyperbolic orbits (since they have these orbits, they only pass our solar system once) and the sonic boom traces out the shape of an hyperbola at ground level.

The equations to these hyperbolae have a lot in common with the ellipses. The equation to the hyperbola in figure 5.58 is

$$y^2 - x^2 = 2$$

while that of figure 5.59 is

$$x^2 - y^2 = 2$$

Just like the ellipse, we often write equations to hyperbolae equal to one. So the equations above become:

$$\frac{y^2}{2} - \frac{x^2}{2} = 1$$

$$\frac{x^2}{2} - \frac{y^2}{2} = 1$$

We can change the general shapes of these graphs stretching them horizontally or vertically by dividing the  $x$  and  $y$  by different numbers, in much the same way as the shape of the ellipse was changed.

We can use Graphmatica to investigate the effect of changing the general equation

$$\left(\frac{x}{a}\right)^2 - \left(\frac{y}{b}\right)^2 = 1 \text{ and } \left(\frac{y}{b}\right)^2 - \left(\frac{x}{a}\right)^2 = 1.$$

First let's just change the value of  $a$  by giving  $b$  a value of 3.

**Figure 5.60:** Graphs of the family of hyperbolae  $\left(\frac{x}{a}\right)^2 - \left(\frac{y}{3}\right)^2 = 1$

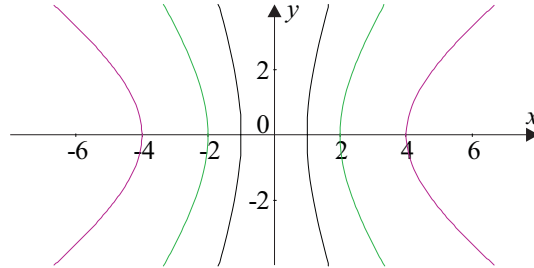

In figure 5.60, the equation  $\left(\frac{x}{a}\right)^2 - \left(\frac{y}{3}\right)^2 = 1$  has  $a = 1, 2$  and  $4$  as you move further away from the origin.

You should have noticed that the value of  $a$  gives the  $x$ -intercept in the graph.

What do you notice about the relationship between the values of  $a$  and  $b$  and the graph?

You may also have noticed the curves seem to have another constraint on them, that is, how ‘bent’ they appear. Remember with rectangular hyperbolas, the asymptotes were the  $x$  and  $y$ -axes or lines parallel to them? Well if we rotated the hyperbola, then we have rotated the asymptotes  $45^\circ$  as well. What is happening here is that a set of asymptotes passing through the origin, are formed. Their equations are based on the values of  $a$  and  $b$ . Can you see what these equations would be? Look at the graph of  $x^2 - y^2 = 1$ , what are the equations to these asymptotes?

**Figure 5.61:** Graph of  $x^2 - y^2 = 1$  and its asymptotes

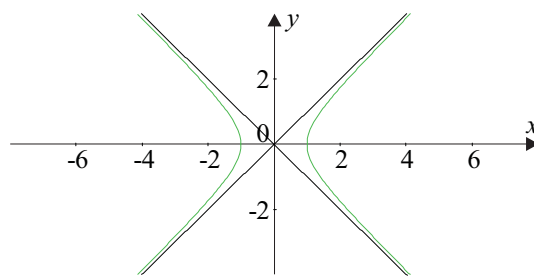

If you said the asymptotes are  $y = \pm x$  in the case above you would be right. Try drawing some on your graphs in figure 5.60, like the one in figure 5.61. In these graphs, they all follow the same basic equation  $\left(\frac{x}{a}\right)^2 - \left(\frac{y}{3}\right)^2 = 1$ . If you draw the asymptotes of these hyperbolas, you would see that for the hyperbolas:

$$\left(\frac{x}{1}\right)^2 - \left(\frac{y}{3}\right)^2 = 1, \text{ asymptotes are } y = \pm 3x$$

$$\left(\frac{x}{2}\right)^2 - \left(\frac{y}{3}\right)^2 = 1, \text{ asymptotes are } y = \pm \frac{3}{2}x$$

$$\left(\frac{x}{4}\right)^2 - \left(\frac{y}{3}\right)^2 = 1, \text{ asymptotes are } y = \pm \frac{3}{4}x$$

In general, the asymptotes for the hyperbola  $\left(\frac{x}{a}\right)^2 - \left(\frac{y}{b}\right)^2 = 1$  are  $y = \pm \frac{b}{a}x$ .

### Activity 5.15

1. (a) Write the general equation of a circle, centre  $(h, k)$ , and radius  $r$ .
- (b) (i) What is the equation of the circle below:
- (ii) Write the equation for the enlargement of the circle (about its centre) by a factor 3.

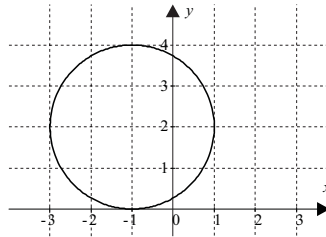

2. (i) Sketch the graph of  $x^2 + y^2 = 1$ .
- (ii) On the same axes, stretch the graph horizontally by factor 1.5 as well as vertically by factor 3.
- (iii) Write its equation.
3. (a) The hyperbola  $y = \frac{1}{x}$  is drawn below.
  - (i) What are the coordinates of A and B?
  - (ii) What is the distance OA?

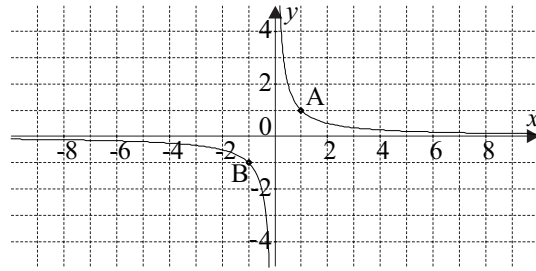

- (b) The hyperbola is now rotated anticlockwise through an angle of  $45^\circ$ .
- Sketch the graph.
  - What are the coordinates of  $A'$  and  $B'$ , the image points of A and B?
  - What is the equation (eq.1) of the rotated graph?
- (c) Rotate the image through a further  $45^\circ$ .
- Sketch the graph.
  - What are the coordinates of  $A''$  and  $B''$ ?
  - What is the equation (eq.2)?
- (d) Rotate the graph of eq.2 through another  $45^\circ$ .
- Sketch the graph.
  - Write its equation (eq.3).
  - Write the equations of the asymptotes.

4. Match each of the equations below to one of the following six graphs:

- |   |  |   |
|---|--|---|
| (a) $x^2 - y^2 = 1$   | (b) $y^2 - x^2 = 1$                        | (c) $\left(\frac{x}{2}\right)^2 - \left(\frac{y}{3}\right)^2 = 1$ |
| (d) $\left(\frac{y}{2}\right)^2 - \left(\frac{x}{3}\right)^2 = 1$ | (e) $\left(\frac{y}{2}\right)^2 - x^2 = 1$ | (f) $\left(\frac{x}{3}\right)^2 - \left(\frac{y}{2}\right)^2 = 1$ |

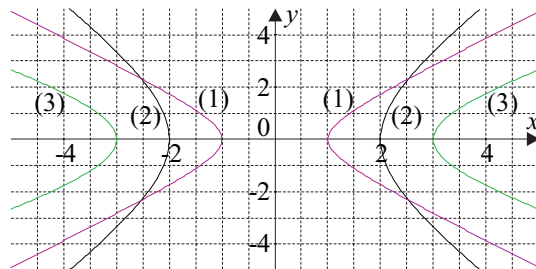

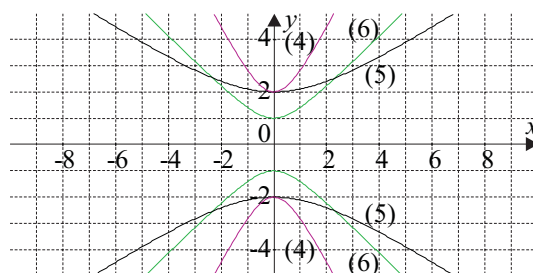

**For your interest only. You do not have to learn this.**

In the last few sections, have you noticed similarity between the equations to the curves? Let's have a brief look at a few of these again:

Circle  $x^2 + y^2 = 1$

Ellipse  $\left(\frac{x}{a}\right)^2 + \left(\frac{y}{b}\right)^2 = 1$

Hyperbola  $\left(\frac{x}{a}\right)^2 - \left(\frac{y}{b}\right)^2 = 1$

Parabola  $y - x^2 = 1$

This similarity has been known for a few thousand years. Appolonius of Alexandria wrote about these curves in his book *Conic Sections* in about 200 BC. In the figure below you can see two cones and by cutting these cones through different sections, you can obtain the 4 'conic sections'

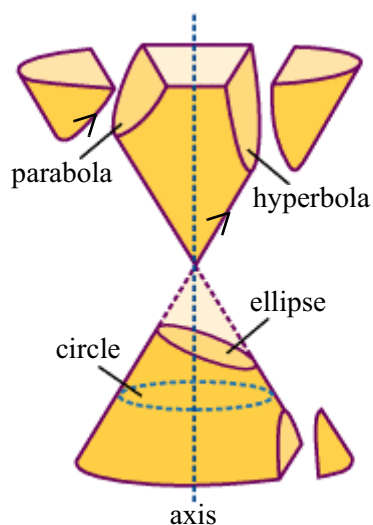

(Source: [http://zebu.uoregon.edu/~js/glossary/conic\\_sections.html](http://zebu.uoregon.edu/~js/glossary/conic_sections.html))

That's the end of this module. Hopefully you have increased the number of tools in your mathematical toolbox, and you can start to see you have a choice in which tool to use in solving many mathematical problems.

Before you finally finish you should do a number of things:

1. Have a look at your action plan for study. Are you still on schedule? Do you need to contact your tutor to discuss any delays or concerns?
2. Make a summary of the important points in this module, noting your strengths and weaknesses. Remember this can be used when you create your summary sheet you can bring into the examination.
3. Practise some real world problems in 'A taste of things to come'.
4. Check your skill level by attempting the post-test.
5. When you are ready, complete and submit your assignment.

## 5.5 A taste of things to come

### Planetary motion

When investigating conic sections, one important point to be considered is the **focus**. Consider the ellipse. We can draw an ellipse by taking a piece of string and attaching the ends to two pins. Then take a pencil and, keeping the string taut, draw an ellipse.

**Figure 5.62:** Drawing an ellipse using pencil and string

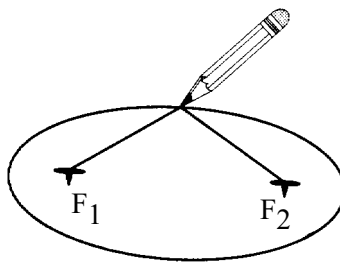

The points of the pins are called the **foci** of the ellipse (one point is a focus). If we put the ellipse into the Cartesian co-ordinate system, the standard form of the equation to the ellipse will be  $\frac{x^2}{a^2} + \frac{y^2}{b^2} = 1$  where  $a$  is the length of the semi **major axis** and  $b$  is the length of the semi **minor axis** of the ellipse. The distance  $c$  from the centre to a focus is called the focal length where  $c^2 = a^2 - b^2$  (Pythagoras theorem). Then the coordinates of the foci  $F_1$  and  $F_2$  will be  $(-c, 0)$  and  $(c, 0)$ .

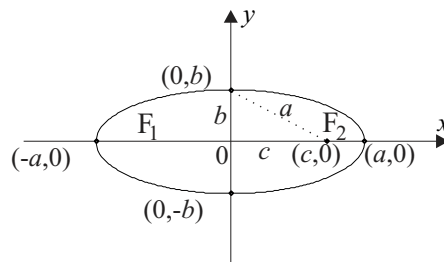
**Figure 5.63:** An ellipse showing the intercepts, foci and axes

Johannes Kepler in the early 17th century discovered three laws related to the movements of planets. These were:

- each planet moves in an ellipse with the sun as the focus;
- the radius vector sweeps out equal areas in equal times; and
- the square of the period of revolution about the sun is proportional to the cube of the semi-major axis of the orbit.

We will have a look at the second law when we study module 6. But let's take a closer look at the other two laws.

- (i) The earth travels in an elliptical orbit around the sun. The distance from the centre of the ellipse to the vertex is 148 million kilometres, and the focal length is 2.47 million kilometres. What is the equation of the ellipse?
- (ii) From Kepler's third law we can state:

$\tau = ca^{\frac{3}{2}}$ , where  $\tau$  is the period of revolution and  $a$  is the semi major axis of orbit. ( $\tau$  is the Greek letter tau, pronounced as rhyming with how). In the case of the earth,  $\tau$  is 1 year. A unit that is quite helpful here is the astronomical unit measuring is 148 million kilometres (i.e. the average distance from the earth to the sun – the semi major axis of orbit). So we have:

$$\tau = ca^{\frac{3}{2}}$$

$$1 = c \times 1^{\frac{3}{2}}$$

$$1 = c$$

We can use this relationship to find the period of revolution of other planets.

If Mars was on average 225.6 million kilometres from the sun, what is its period of revolution?

- (iii) If Uranus has a period of 84.02 years, an average, how far is it from the sun?

### Investigating other curves and their equations

Let's investigate an array of other curves you may not have come across before. Some of these curves are expressed parametrically. What you should do, is to graph them on Graphmatica and then change the parameters to see the effect. You should then be able to transform some of them using the rules in the previous sections.

The equation below creates the figure of a top as seen in figure 5.64:

$$\frac{x^2}{y^3} + y = 2$$

**Figure 5.64:** Graph of  $\frac{x^2}{y^3} + y = 2$

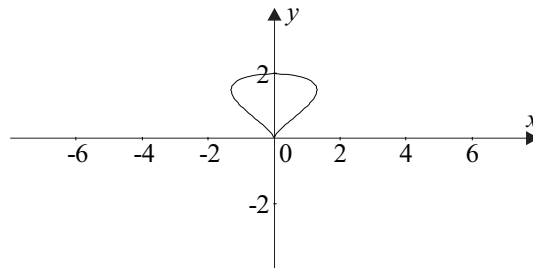

Enlarge the shape of the top by changing the constant (similar to the circle enlargement).

Figure 5.65 comes from the equation  $\frac{x^2}{y^3} + y = 4$ .

**Figure 5.65:** Graph of  $\frac{x^2}{y^3} + y = 4$

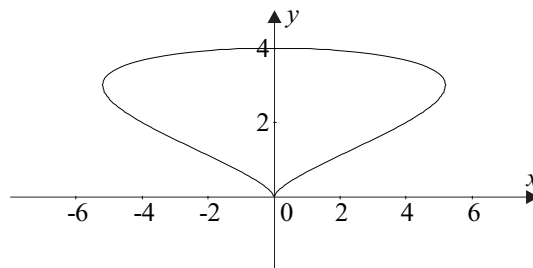

Create an equation that moves the top horizontally and another that moves the top vertically.

If we want to move it horizontally one unit to the right, the values of  $x$  change so the equation now becomes  $\frac{(x-1)^2}{y^3} + y = 2$ , as seen in figure 5.66.

If we want to move it vertically two units up, the values of  $y$  change and the equation becomes

$$\frac{x^2}{(y-2)^3} + (y-2) = 2, \text{ as seen in figure 5.66.}$$

**Figure 5.66:** Graphs of  $\frac{(x-1)^2}{y^3} + y = 2$  and  $\frac{x^2}{(y-2)^3} + (y-2) = 2$

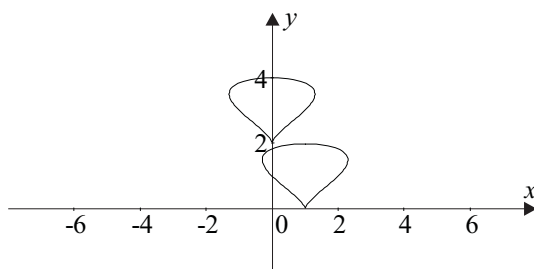
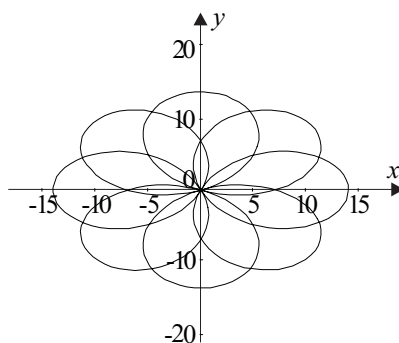

Figure 5.67 depicts a rosette. The parametric equations (using 0 to  $2\pi$  domain) are:

$$x = 7 \cos t + 7 \cos 7t$$

$$y = 7 \sin t - 7 \sin 7t$$

**Figure 5.67:** Graph of a rosette



Translate it so the new rosette has its centre at  $(-2,7)$ .

To move it the new equation becomes:

$$(x+2) = 7 \cos t + 7 \cos 7t$$

$$(y-7) = 7 \sin t - 7 \sin 7t$$

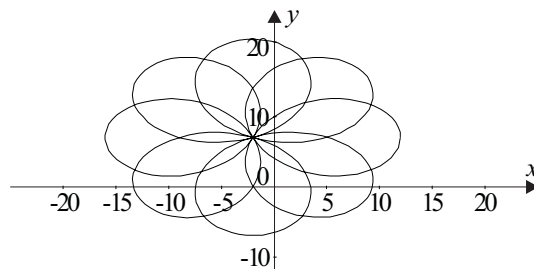
**Figure 5.68:** Graph of rosette with centre  $(-2,7)$ 

## 5.6 Post-test

1. A rescue boat is 10 nautical miles from port at a bearing  $E 30^\circ N$  (i.e  $30^\circ$  North of East). It receives a message from port to go to the aid of a yacht stranded 25 nm NW of port.
  - (i) Taking the positive direction of the  $x$ -axis as due East, write the polar coordinates of the rescue boat (R) and the yacht (S).
  - (ii) Write R and S as position vectors in component form.
  - (iii) Find the displacement vector, RS, giving the answer in polar form.
  - (iv) What does this displacement vector represent in practical terms?
2. Write the equation  $2y = 3x - 1$ 
  - (i) in vector form
  - (ii) in parametric form.
  - (iii) two points  $P(2, 2.5)$  and  $Q(-2, -3.5)$  are on the line. Find the mid-point of segment PQ.
3. P is the point  $(-3, 4)$ .
  - (i) Reflect P in the line  $y = x$ . ( $P_a$ )
  - (ii) Translate the point P two units to the right and six units vertically downwards. ( $P_b$ )
  - (iii) Rotate P anti-clockwise through an angle of  $90^\circ$ . ( $P_c$ )

4. What type of transformation has been used to change figure A to figure B in each of the following:

(a)

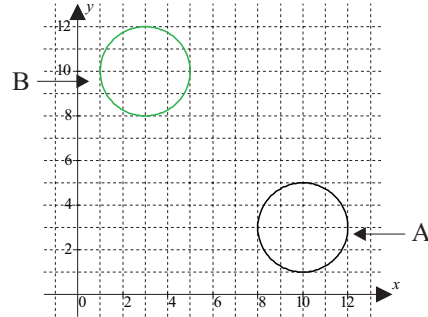

(b)

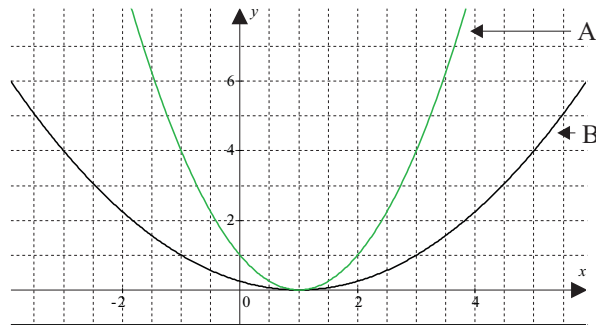

(c)

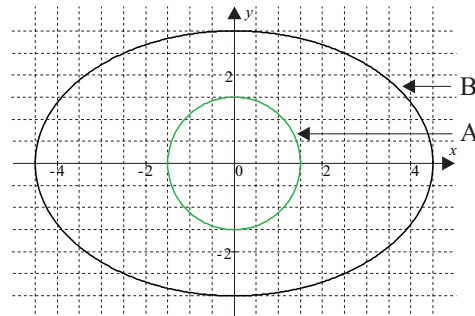

(d)

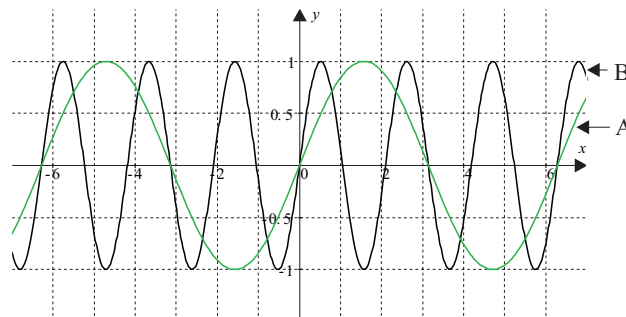

(e)

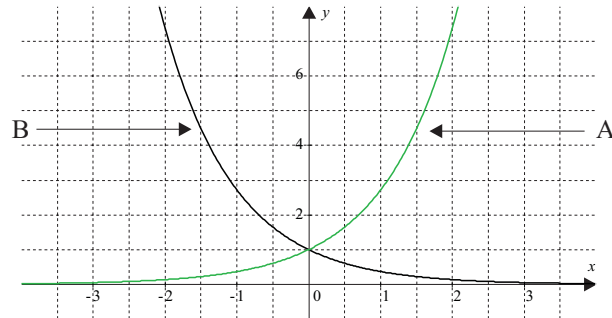

(f)

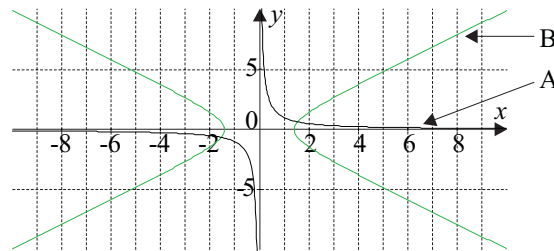

- One measure used to avoid air collisions is to fly aircraft travelling in opposite directions at different altitudes. A further safety measure for our highway-in-the-sky is the use of radar. If a Boeing 747 sets its radar to pick up other aircraft within a 50 nm radius, what Cartesian equation should be programmed into the radar?

## 5.7 Solutions

### Solutions to activities

#### Activity 5.1

1. Polar coordinates in terms of  $(r, \theta)$

$$M(3, 45^\circ) \text{ or } \left(3, \frac{\pi}{4}\right) \text{ or } (3, 405^\circ)$$

$$N(2.5, 180^\circ) \text{ or } (2.5\pi) \text{ or } (2.5, -180^\circ)$$

$$Q(4, 225^\circ) \text{ or } \left(4, \frac{5\pi}{4}\right) \text{ or } (4, -135^\circ)$$

$$P(1, 300^\circ), \left(1, \frac{10\pi}{6}\right) \text{ or } (1, -60^\circ)$$

- 2.

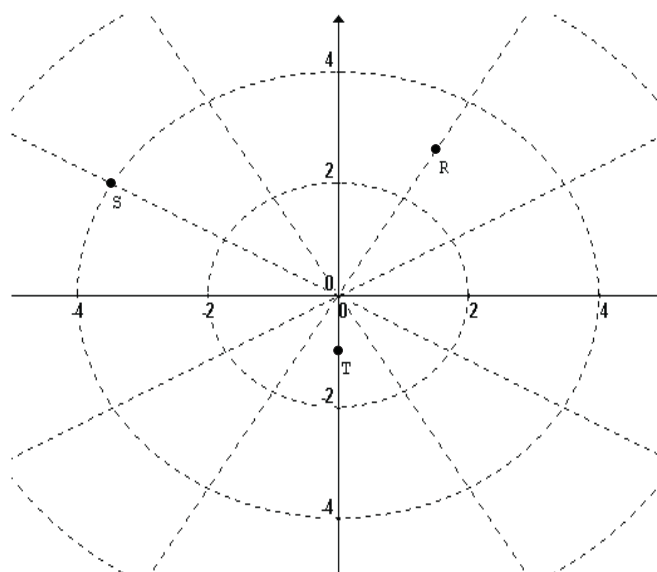

#### Activity 5.2

1. Conversion sequence for Casio *fx-115*: [x-value] [inv] [R  $\rightarrow$  P] [y-value] [=] gives  $r$   
[X  $\leftrightarrow$  Y] gives  $\theta$

$$\begin{aligned}
 \text{(a) (i)} \quad r &= \sqrt{(-1)^2 + (1)^2} \\
 &= \sqrt{2} \\
 \theta &= \cos^{-1} \frac{-1}{\sqrt{2}} \\
 &= 135^\circ \qquad \qquad \qquad (-1,1) = (\sqrt{2}, 135^\circ)
 \end{aligned}$$

$$\begin{aligned}
 \text{(ii)} \quad r &= \sqrt{(-0.5)^2 + (-1)^2} \\
 &= \sqrt{1.25} = 1\frac{1}{4} = \sqrt{\frac{5}{4}} = \frac{\sqrt{5}}{\sqrt{4}} = \frac{\sqrt{5}}{2} \approx 1.12 \\
 \theta &= \cos^{-1} \left( \frac{-0.5}{\sqrt{1.25}} \right) \\
 &= 243.43\dots \text{ (since its in the 3rd quadrant)} \\
 &\approx 243.4^\circ \quad (-0.5, -1) = (1.12, 243.4^\circ)
 \end{aligned}$$

$$\begin{aligned}
 \text{(iii)} \quad r &= 0.2 \text{ (by inspection)} \\
 \theta &= 90^\circ \text{ ( " " )} \quad (0,0.2) = (0.2, \frac{\pi}{2})
 \end{aligned}$$

$$\text{(c) (i) } (3,4) \approx (5, 53^\circ)$$

$$\text{(ii) } (1, \sqrt{3}) = (2, 60^\circ)$$

2. (a) Conversion formulae:  $x = r \cos \theta$      $y = r \sin \theta$

$$\begin{aligned}
 \text{(i) } (r, \theta) = (3, 30^\circ) &\Rightarrow x = 3 \cos 30^\circ, \quad y = 3 \sin 30^\circ \\
 &\Rightarrow x = \frac{3\sqrt{3}}{2} \quad \text{or } x \approx 2.6, \quad y = 1.5
 \end{aligned}$$

$$\begin{aligned}
 \text{(ii) } (r, \theta) = (2, 89^\circ) &\Rightarrow x = 2 \cos 89^\circ, \quad y = 2 \sin 89^\circ \\
 &\Rightarrow x \approx 0.0349, \quad y \approx 1.9997
 \end{aligned}$$

$$\begin{aligned}
 \text{(iii) } (r, \theta) = (1, \frac{4\pi}{3}) &\Rightarrow x = \cos \frac{4\pi}{3}, \quad y = \sin \frac{4\pi}{3} \\
 &\Rightarrow x = -0.5, \quad y = -\frac{\sqrt{3}}{2} \quad \text{or } y \approx -0.866
 \end{aligned}$$

(b) Sequence for Casio fx-115: [radius] [INV] [P → R] [angle] [=] (displays  $x$  value)  
 [X ↔ Y] displays  $y$  value

$$\text{(i) } (1.5, 3\pi) \Rightarrow (-1.5, 0) \quad \text{remember to work in RADIANS on your calculator}$$

$$\text{(ii) } (2, -120^\circ) \Rightarrow (-1, -1.732) \quad \text{remember to change back to DEGREES!}$$

**Activity 5.3**

(Remember: Vectors have both MAGNITUDE and DIRECTION)

**Distance** is a measurement without any particular direction and is therefore a **scalar**.

**Time** is a measure without direction. It is therefore a **scalar**.

**Velocity** is a measure of speed in a particular direction. It is a **vector**.

The weight and distance are scalars but the force is a vector. **Force** is a push or pull on an object. It has magnitude (usually measured in Newtons) as well as a direction of application. It is a **vector**.

**Mass** is a measure of the magnitude of an object. It is a **scalar**.

**Acceleration** is the rate of change of velocity (a vector) per time-unit. It has both magnitude and direction and is therefore a **vector**.

Since **direction** has no magnitude it is neither a scalar nor a vector.

**Activity 5.4**

1. Use the Pythagorean Theorem for magnitude of vectors:

$$\begin{aligned} \text{(a) } |\vec{a}| &= \sqrt{5^2 + 12^2} \\ &= \sqrt{169} &= 13 \end{aligned}$$

$$\begin{aligned} \text{(b) } |\vec{b}| &= \sqrt{(-\sqrt{3})^2 + 1^2} \\ &= \sqrt{4} &= 2 \end{aligned}$$

$$\begin{aligned} \text{(c) } |\vec{c}| &= \sqrt{(-2a)^2 + (-m)^2} \\ &= \sqrt{4a^2 + m^2} \end{aligned}$$

$$\begin{aligned} 2. \quad |\vec{v}| &= \sqrt{x^2 + y^2} \\ 7 &= \sqrt{t^2 + 3^2} \\ 49 &= t^2 + 9 \quad (\text{squaring both sides}) \\ t^2 &= 40 \\ t &= \pm\sqrt{40} = \pm 2\sqrt{10} \end{aligned}$$

**Activity 5.5**

$$\begin{aligned} 1. \text{ (a) } \vec{a} &= (3, 30^\circ) \\ &= 3 \cos 30^\circ \vec{i} + 3 \sin 30^\circ \vec{j} \\ &= \frac{3\sqrt{3}}{2} \vec{i} + \frac{3}{2} \vec{j} \approx 2.6 \vec{i} + 1.5 \vec{j} \end{aligned}$$

$$\begin{aligned}
 \text{(b) } \vec{b} &= (2, 220^\circ) \\
 &= 2 \cos 220^\circ \vec{i} + 2 \sin 220^\circ \vec{j} \\
 &\approx -1.53 \vec{i} - 1.29 \vec{j}
 \end{aligned}$$

$$\begin{aligned}
 \text{(c) } \vec{c} &= \begin{pmatrix} -2 \\ 0 \end{pmatrix} \\
 &= -2 \vec{i} + 0 \vec{j} \text{ or } -2 \vec{i}
 \end{aligned}$$

2.

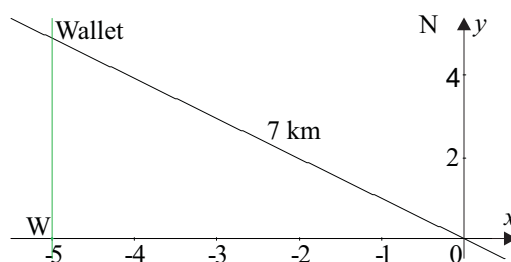

$$\begin{aligned}
 x\text{-component} &= -5 \\
 &= \sqrt{7^2 - 5^2}
 \end{aligned}$$

$$\begin{aligned}
 y\text{-component} &= \sqrt{24} \\
 &= 2\sqrt{6}
 \end{aligned}$$

Therefore, the wallet is located at  $-5\vec{i} + 2\sqrt{6}\vec{j}$ .

3. The position vector for point A is  $\vec{OA} = \begin{pmatrix} 3 \\ 1 \end{pmatrix}$  and point B is  $\vec{OB} = \begin{pmatrix} -1 \\ 5 \end{pmatrix}$

Now to get from A to B we could go from A to the origin and the origin to B:

$$\begin{aligned}
 \vec{AB} &= \vec{AO} + \vec{OB} \text{ however } \vec{AO} = -\vec{OA} \text{ so} \\
 \vec{AB} &= -\vec{OA} + \vec{OB} \\
 \vec{AB} &= -\begin{pmatrix} 3 \\ 1 \end{pmatrix} + \begin{pmatrix} -1 \\ 5 \end{pmatrix} = \begin{pmatrix} -4 \\ 4 \end{pmatrix}
 \end{aligned}$$

**Activity 5.6**

$$4y = x + 4$$

1. (a)  $y = \frac{1}{4}x + 1$

Taking the position vector  $\begin{pmatrix} -4 \\ 0 \end{pmatrix}$ , we move 4 units horizontally and 1 unit vertically  $t$

number of times. The vector equation becomes:  $\begin{pmatrix} x \\ y \end{pmatrix} = t \begin{pmatrix} 4 \\ 1 \end{pmatrix} + \begin{pmatrix} -4 \\ 0 \end{pmatrix}$  (we could have taken other position vectors).

(b)  $x = 4t - 4$   
 $y = t$

2. (a)

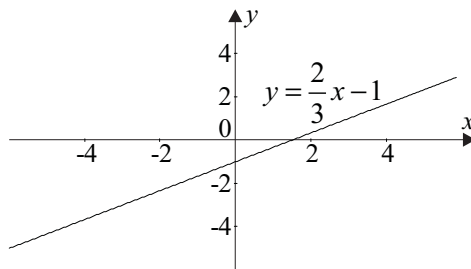

(b)  $\begin{pmatrix} x \\ y \end{pmatrix} = t \begin{pmatrix} 3 \\ 2 \end{pmatrix} + \begin{pmatrix} 0 \\ -1 \end{pmatrix}$  (any position vector located on the line may replace  $\begin{pmatrix} 0 \\ -1 \end{pmatrix}$ )

(c)  $x = 3t$  (1)  
 $y = 2t - 1$  (2)

$$t = \frac{1}{3}x \quad \text{– from (1)}$$

$$t = \frac{1}{2}y + \frac{1}{2} \quad \text{– from (2)}$$

$$\frac{1}{2}y + \frac{1}{2} = \frac{1}{3}x$$

$$\frac{1}{2}y = \frac{1}{3}x - \frac{1}{2}$$

$$y = \frac{2}{3}x - 1 \quad \text{(verified)}$$

(d) : determined by:

- its gradient and one point on the line, or
- two points on the line

A. Check the gradient:

$$m = \frac{3}{2} \neq \frac{2}{3} \quad (\text{not same gradient})$$

A is not the same line. (A)

B. Check gradient:

$$m = \frac{2}{3} \quad (\text{same})$$

Check point, say  $(0, -1)$ :

$$\begin{pmatrix} 0 \\ -1 \end{pmatrix} = -1 \begin{pmatrix} 3 \\ 2 \end{pmatrix} + \begin{pmatrix} 3 \\ 1 \end{pmatrix} \quad (\text{correct for } t = -1)$$

B is the same line. (B)

C. Check gradient:

$$m = \frac{2}{3} \quad (\text{same})$$

Check point  $(0, -1)$ :

$$\begin{pmatrix} 0 \\ -1 \end{pmatrix} = -2 \begin{pmatrix} 3 \\ 2 \end{pmatrix} + \begin{pmatrix} 6 \\ 3 \end{pmatrix} \quad (\text{correct for } t = -2)$$

C is the same line. (C)

D. Check gradient:

$$m = \frac{2}{3} \quad (\text{same})$$

Check point  $(0, -1)$ :

$$\begin{pmatrix} 0 \\ -1 \end{pmatrix} \neq 2 \begin{pmatrix} 3 \\ 2 \end{pmatrix} + \begin{pmatrix} -6 \\ -3 \end{pmatrix} \quad [(0, -1) \text{ not on line}]$$

D is not the same line. (D)

### Activity 5.7

$$\begin{aligned}
 1. \quad d &= \sqrt{(x_2 - x_1)^2 + (y_2 - y_1)^2} \\
 \overline{ST} &= \sqrt{(1.5 + 3)^2 + (3 + 1)^2} \\
 &= \sqrt{20.25 + 16} \\
 &= \sqrt{36.25} \\
 &\approx 6.02
 \end{aligned}$$

$$\begin{aligned}
 2. \quad Q &\leftrightarrow \left(\frac{3}{4}, -\frac{1}{2}\right) \Rightarrow |\vec{q}| = \sqrt{\left(\frac{3}{4}\right)^2 + \left(-\frac{1}{2}\right)^2} \\
 &= \sqrt{\frac{13}{16}} \\
 &= \frac{1}{4}\sqrt{13}
 \end{aligned}$$

$$\begin{aligned}
 3. \quad \overline{AB} &= \vec{b} - \vec{a} \\
 &= (\vec{i} - 2\vec{j}) - (2\vec{i} + \vec{j}) \\
 &= -\vec{i} - 3\vec{j} \\
 |\overline{AB}| &= \overline{AB} \\
 &= \sqrt{(-1)^2 + (-3)^2} \\
 &= \sqrt{10} \\
 &\approx 3.16
 \end{aligned}$$

$$4. \quad \text{Let Joe's position} = \vec{s} = (4, 45^\circ)$$

$$\text{Let Nadia's position} = \vec{n} = (10, 240^\circ)$$

Then:

$$\begin{aligned}
 \vec{s} &= \begin{pmatrix} 4 \cos 45 \\ 4 \sin 45 \end{pmatrix} = \begin{pmatrix} 2\sqrt{2} \\ 2\sqrt{2} \end{pmatrix} \\
 \vec{n} &= \begin{pmatrix} 10 \cos 240 \\ 10 \sin 240 \end{pmatrix} = \begin{pmatrix} -5 \\ -5\sqrt{3} \end{pmatrix}
 \end{aligned}$$

$$\begin{aligned}
 \text{Distance apart} &= |\vec{s} - \vec{n}| \\
 &= \sqrt{(2\sqrt{2} + 5)^2 + (2\sqrt{2} + 5\sqrt{3})^2} \\
 &= \sqrt{193.27\dots} \\
 &\approx 13.9
 \end{aligned}$$

Nadia and Joe are approximately 13.9 km apart.

**Activity 5.8**

1. Mid-point theorem:  $x_M = \frac{x_1 + x_2}{2}$ ,  $y_M = \frac{y_1 + y_2}{2}$

(a)  $M_{AB} = \left( \frac{0+5}{2}, \frac{4+1}{2} \right) = (2.5, 2.5)$

(b)  $M_{XZ} = \left( \frac{-2+4}{2}, \frac{3-4}{2} \right) = (1, -0.5)$

(c)  $M_{RS} = \left( \frac{-1-1}{2}, \frac{-3+6}{2} \right) = (-1, 1.5)$

(d)  $M_{GH} = \left( \frac{g-2g}{2}, \frac{-g+g}{2} \right) = \left( \frac{-g}{2}, 0 \right)$

2.  $\overline{OM} = \frac{1}{2} \begin{pmatrix} 3+^{-2} \\ 3+^{-3} \end{pmatrix} = \frac{1}{2} \begin{pmatrix} 1 \\ 0 \end{pmatrix} = \begin{pmatrix} 0.5 \\ 0 \end{pmatrix}$

3. Point of intersection of diagonals is the mid-point of each.

$$M_{AB} = \left( \frac{5-1}{2}, \frac{-2+4}{2} \right) = (2, 1)$$

The diagonals intersect at the point (2,1).

(2,1) is also the mid-point of OC.

$$(2, 1) = \left( \frac{0+x_C}{2}, \frac{0+y_C}{2} \right)$$

$$\frac{x_C}{2} = 2 \quad \text{and} \quad \frac{y_C}{2} = 1$$

$$x_C = 4 \quad y_C = 2$$

$\therefore$  C is the point (4,2).

Or you could solve this using simultaneous equations, finding the equations of gradient of AC and BC.

Gradient of AC = gradient of OB = -4

$$\text{Gradient of AC} = \frac{y_2 + 2}{x_2 - 5} = -4$$

$$y_2 + 2 = -4(x_2 - 5)$$

$$y_2 + 2 = -4x_2 + 20$$

$$y_2 = -4x_2 + 18$$

$$\text{Gradient of BC} = \text{gradient of OA} = \frac{0+2}{0-5} = -\frac{2}{5}$$

$$\begin{aligned}\text{Gradient of BC} &= \frac{y_2-4}{x_2+1} = -\frac{2}{5} \\ y_2-4 &= -\frac{2}{5}(x_2+1) \\ y_2-4 &= -\frac{2}{5}x_2 - \frac{2}{5} \\ y_2 &= -\frac{2}{5}x_2 + \frac{18}{5}\end{aligned}$$

Now we have simultaneous equations:

$$\begin{aligned}y_2 &= -\frac{2}{5}x_2 + \frac{18}{5} \\ y_2 &= -4x_2 + 18 \\ -\frac{2}{5}x_2 + \frac{18}{5} &= -4x_2 + 18 \\ -2x_2 + 18 &= -20x_2 + 90 \\ 18x_2 &= 72 \\ x_2 &= 4 \\ \therefore y_2 &= 18 - 4 \times 4 = 2\end{aligned}$$

### Activity 5.9

1. (a)  $x^2 + y^2 = 4$  (Circle, centre 0, radius 2)

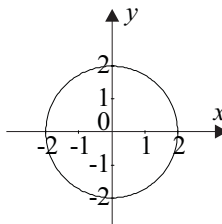

- (b)  $x^2 + y^2 = 2.25$  (Circle, centre 0, radius 1.5)

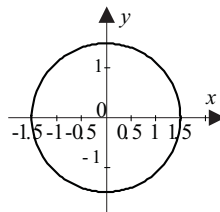

2. Circle, centre 0, radius 3

$$x^2 + y^2 = 3^2$$

$$x^2 + y^2 = 9$$

3. Circle, centre (0,0), radius 2.5

$$x^2 + y^2 = 2.5^2$$

$$x^2 + y^2 = 6.25$$

Circle, centre (0,0), point (-4,3)

$$r^2 = (-4)^2 + 3^2 = 25$$

$$x^2 + y^2 = 25$$

### Activity 5.10

1. Smallest circle with radius 1

$$x^2 + y^2 = 1$$

Middle circle with radius 2

$$x^2 + y^2 = 2^2$$

$$x^2 + y^2 = 4$$

Largest circle with radius 3

$$x^2 + y^2 = 3^2$$

$$x^2 + y^2 = 9$$

2. Parametric equations:  $x = r \cos q$ ,  $y = r \sin q$

(a)  $x = 2 \cos q$ ,  $y = 2 \sin q$

(b)  $x = 1.5 \cos q$ ,  $y = 1.5 \sin q$

3. Given point (5,-7), centre O:

$$r^2 = 5^2 + (-7)^2$$

$$r = \sqrt{74} \quad (\text{Polar form})$$

### Activity 5.11

1. The point will be reflected in the  $y$ -axis  $\begin{pmatrix} -1 & 0 \\ 0 & 1 \end{pmatrix} \begin{pmatrix} 1 \\ -3 \end{pmatrix} = \begin{pmatrix} -1 \\ -3 \end{pmatrix}$

$$\begin{pmatrix} -1 & 0 \\ 0 & 1 \end{pmatrix} \begin{pmatrix} -2 \\ 4 \end{pmatrix} = \begin{pmatrix} 2 \\ 4 \end{pmatrix}$$

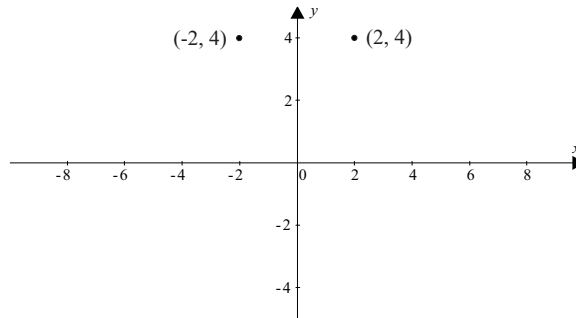

$$2. \begin{pmatrix} 1 & 0 \\ 0 & -1 \end{pmatrix} \begin{pmatrix} 30 \\ 21 \end{pmatrix} = \begin{pmatrix} 30 \\ -21 \end{pmatrix}.$$

$$3. \begin{pmatrix} 0 & 1 \\ 1 & 0 \end{pmatrix} \text{ reflects coordinates in the line } y = x.$$

$$\begin{pmatrix} 0 & 1 \\ 1 & 0 \end{pmatrix} \begin{pmatrix} -3 \\ -3 \end{pmatrix} = \begin{pmatrix} -3 \\ -3 \end{pmatrix}. \text{ The coordinates do not change as the point lies on the line.}$$

$$4. \begin{pmatrix} 0 & -1 \\ -1 & 0 \end{pmatrix} \begin{pmatrix} 4 \\ -5 \end{pmatrix} = \begin{pmatrix} 5 \\ -4 \end{pmatrix}. \text{ The transformation is a reflection in the line } y = -x.$$

$$5. \begin{pmatrix} 1 & 0 \\ 0 & -1 \end{pmatrix} \begin{pmatrix} 3 \\ 2 \end{pmatrix} = \begin{pmatrix} 3 \\ -2 \end{pmatrix} \text{ reflection in } x\text{-axis.}$$

$$\begin{pmatrix} 0 & 1 \\ 1 & 0 \end{pmatrix} \begin{pmatrix} 3 \\ -2 \end{pmatrix} = \begin{pmatrix} -2 \\ 3 \end{pmatrix} \text{ Reflected in the line } y = x$$

The coordinates of the final image are  $(-2, 3)$

6. (a)  $(5, -12)$  is in the 4th quadrant.

$$\begin{aligned} r &= \sqrt{5^2 + (-12)^2} \\ &= \sqrt{25 + 144} \\ &= \sqrt{169} \\ &= 13 \end{aligned}$$

$$\cos \theta = \frac{x}{r}$$

$$= \frac{5}{13}$$

$$\approx 0.384$$

$$\theta \approx \cos^{-1} 0.384$$

$$\approx 67.38^\circ$$

The polar coordinates are  $(13, -67.38^\circ)$ .

- (b) We can use matrices on the rectangular coordinates or we can use the polar coordinates and convert back to rectangular coordinates.

After it has been rotated in an anti-clockwise direction through an angle of  $30^\circ$ , (i.e., the new angle will be  $-67^\circ + 30^\circ$ ) the new polar coordinates will be  $(13, -37.38^\circ)$ . To convert this to rectangular coordinates:

$$\begin{aligned}x &= r \cos \theta \\ &= 13 \cos(-37.38^\circ) \\ &\approx 10.33\end{aligned}$$

$$\begin{aligned}y &= r \sin \theta \\ &= 13 \sin(-37.38^\circ) \\ &\approx -7.89\end{aligned}$$

The new coordinates will be approximately  $(10.33, -7.89)$

- (c) Rotating this image through a further angle of  $60^\circ$  gives polar coordinates of  $(13, 23^\circ)$   
To convert to rectangular coordinates:

$$\begin{aligned}x &= r \cos \theta \\ &= 13 \cos(22.62^\circ) \\ &= 12 \\ y &= r \sin \theta \\ &= 13 \sin(22.62^\circ) \\ &= 5\end{aligned}$$

The rectangular coordinates are  $(12, 5)$ .

$$\begin{pmatrix} \cos 90^\circ & -\sin 90^\circ \\ \sin 90^\circ & \cos 90^\circ \end{pmatrix} \begin{pmatrix} 5 \\ -12 \end{pmatrix} = \begin{pmatrix} 5 \cos 90^\circ + 12 \sin 90^\circ \\ 5 \sin 90^\circ - 12 \cos 90^\circ \end{pmatrix} \\ = \begin{pmatrix} -5 \\ 12 \end{pmatrix}$$

- (d) Rotating the original

point  $(5, -12)$  through an angle of  $90^\circ$ , we can use the matrix  $\begin{pmatrix} \cos \theta & -\sin \theta \\ \sin \theta & \cos \theta \end{pmatrix}$

$$\begin{bmatrix} \cos 90^\circ & -\sin 90^\circ \\ \sin 90^\circ & \cos 90^\circ \end{bmatrix} \begin{bmatrix} 5 \\ -12 \end{bmatrix} = \begin{bmatrix} 5 \cos 90^\circ + 12 \sin 90^\circ \\ 5 \sin 90^\circ - 12 \cos 90^\circ \end{bmatrix} \\ = \begin{bmatrix} 12 \\ 5 \end{bmatrix}$$

## Activity 5.12

1.

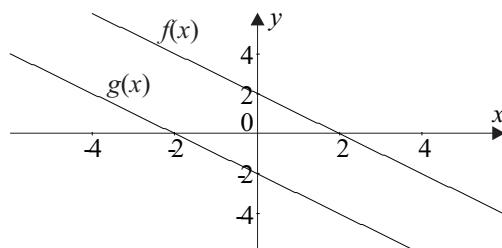

2. (a)

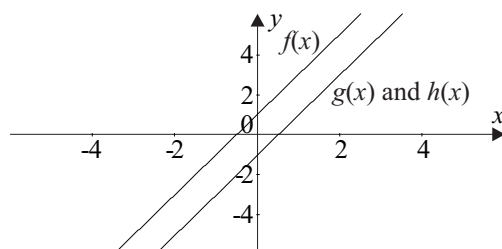

$$\begin{aligned} \text{(b) } g(x) &= 2(x-1) + 1 \\ &= 2x - 1 \end{aligned}$$

$$\begin{aligned} h(x) &= f(x) - 2 \\ &= 2x - 1 \end{aligned}$$

3. (a) (i)

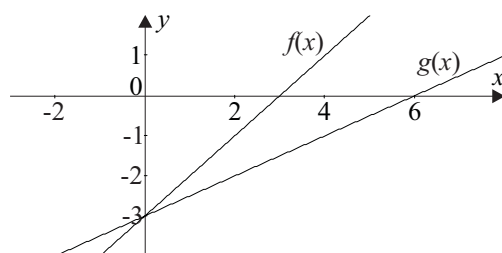

$$\text{(ii) } g(x) = 0.5x - 3$$

$$\begin{aligned} \text{(b) } h(x) &= 3f(x) \\ &= 3x - 9 \end{aligned}$$

(c)  $f(x)$  is stretched by a factor of 2, so the gradient is halved, i.e. 0.5. Since the line is stretched about the line  $x = 1$ , the new function is translated one unit to the right. So the

line  $y = \frac{1}{2}x - 3$  becomes

$$y = \frac{1}{2}(x+1) - 3$$

$$= \frac{1}{2}x - 2.5$$

**Activity 5.13**

1.

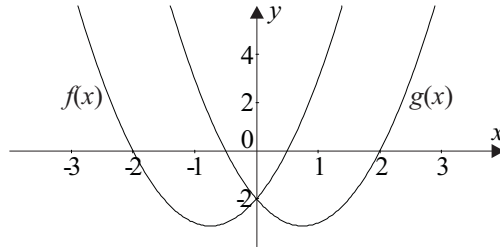

$$g_1(x) = f(-x) \Rightarrow g_1(x) = 2(-x)^2 + 3(-x) - 2 \quad (\text{reflection in } y\text{-axis})$$

$$= 2x^2 - 3x - 2 \quad \text{which is a function.}$$

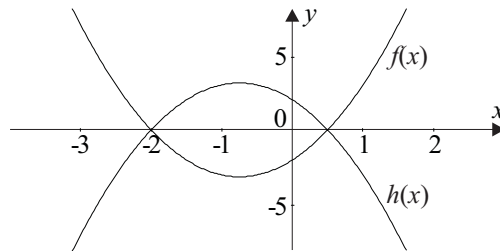

$$h(x) = -f(x) \quad (\text{for reflection in } x\text{-axis})$$

$$= -(2x^2 + 3x - 2)$$

$$= -2x^2 - 3x + 2 \quad \text{which is a function.}$$

Point about graph was rotated is on the  $x$ -axis and the axis of symmetry, i.e.

$$\left( \frac{-2 + 0.5}{2}, 0 \right) = (-0.75, 0).$$

2. (a)

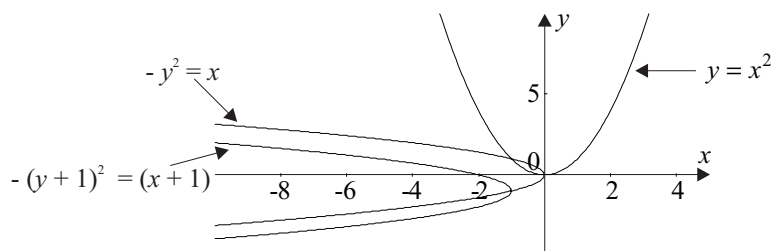

Neither rotations are functions.

(b)  $y = -x^2$  then move it (5,5). The equation now becomes:

$$\begin{aligned} x - 5 &= -(y - 5)^2 \\ x &= -y^2 + 10y - 20 \end{aligned}$$

3. Given  $f(x) = -3x^2 - 1$

(i) Horizontal stretch of factor  $n$

$$\begin{aligned} g_1(x) &= f\left(\frac{x}{n}\right) \\ &= -3\left(\frac{x}{2}\right)^2 - 1 \\ &= -\frac{3}{4}x^2 - 1 \end{aligned}$$

(ii)  $f(x)$  is the steeper curve.

(iii) Vertical stretch of factor  $n$

$$\begin{aligned} g_2(x) &= nf(x) \\ &= 2(-3x^2 - 1) \\ &= -6x^2 - 2 \end{aligned}$$

(iv)  $g_2(x)$  is the steeper curve.

#### Activity 5.14

1.

(i)

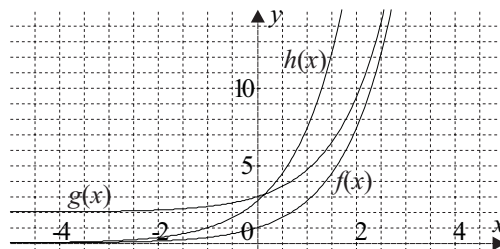

(ii) Equation of new function translating 2 units upwards:

$$\begin{aligned} g(x) &= f(x) + 2 \\ &= e^x + 2 \end{aligned}$$

(iii)  $(0, 1) \rightarrow (0, 3)$

(iv) Under a translation of 1 unit to the left:

$$\begin{aligned} h(x) &= f(x+1) \\ &= e^{x+1} \end{aligned}$$

(v)  $(0, 1) \rightarrow (-1, 1)$

2. (a) Given:  $f(x) = e^x$

$$\text{Horizontal stretch} \Rightarrow g(x) = f\left(\frac{x}{n}\right)$$

$\therefore$  From the graph

$$\begin{aligned} g(4) &= f(2) \\ e^{\frac{4}{n}} &= e^2 \\ n &= 2 \\ g(x) &= e^{\frac{x}{2}} \end{aligned}$$

(b) Given:  $f(x) = \ln x$

$$\text{Vertical stretch} \Rightarrow h(x) = nf(x)$$

From graph

$$\begin{aligned} f(3) &\approx h(1.7) \\ \ln 3 &\approx n \ln 1.7 \\ n &\approx \frac{\ln 3}{\ln 1.7} \\ &= 2 \\ h(x) &= 2 \ln x \end{aligned}$$

3. Given:  $f(x) = \cos x$

From the graph  $f(x)$  has been translated approximately 1.6 (or  $\frac{\pi}{2}$ ) units to the right.

$$\begin{aligned} g(x) &= f\left(x - \frac{\pi}{2}\right) \\ &= \cos\left(x - \frac{\pi}{2}\right) \end{aligned}$$

4. Given:  $f(x) = \cos x$

From the graph  $f(x)$  has been stretched horizontally by a factor of 1.5.

$$\begin{aligned} g(x) &= f\left(\frac{x}{1.5}\right) \\ &= \cos\left(\frac{2x}{3}\right) \end{aligned}$$

From the graph  $f(x)$  has been stretched vertically by factor 3.

$$\begin{aligned} h(x) &= 3f(x) \\ &= 3 \cos x \end{aligned}$$

5. (i)

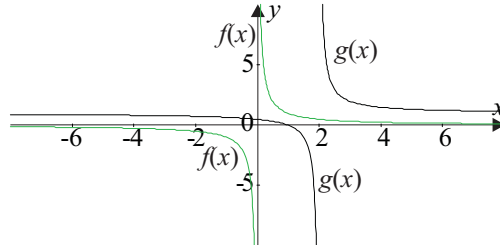

(ii) The graph does not appear to have undergone any transformation as the part of the graph in quadrant 1 has been superimposed on the part of the graph in quadrant 3, and vice versa.

(iii) Under a translation of 2 units to the right and 1 unit upwards  $g(x) = f(x - 2) + 1$ .

(iv)  $g(x) = \frac{1}{(x-2)} + 1$

(v) Asymptotes are the lines  $x = 2$  and  $y = 1$ .

### Activity 5.15

1. (a) General equation of circle:  $(x - h)^2 + (y - k)^2 = r^2$

(b) From the graph:  $(h, k) = (-1, 2)$  and  $r = 2$

(i)  $\Rightarrow (x + 1)^2 + (y - 2)^2 = 4$

(ii) Enlargement is a stretch in both  $x$  and  $y$  directions by factor 3

$$\Rightarrow \left(\frac{x+1}{3}\right)^2 + \left(\frac{y-2}{3}\right)^2 = 4$$

$$\Rightarrow (x+1)^2 + (y-2)^2 = 36$$

2. (i) & (ii)

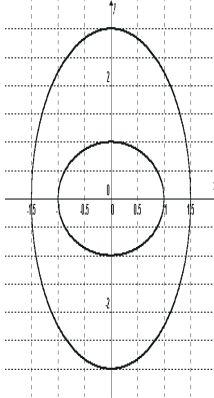

(iii) Equation of the ellipse where  $a = 1.5$ ;  $b = 3$ :

$$\frac{x^2}{1.5^2} + \frac{y^2}{3^2} = 1 = \frac{x^2}{2.25} + \frac{y^2}{9}$$

Or you could do it with fractions:

$$\frac{x^2}{2\frac{1}{4}} + \frac{y^2}{9} = 1$$

$$\frac{4x^2}{9} + \frac{y^2}{9} = 1$$

$$\left(\frac{2x^2}{3}\right)^2 = \left(\frac{y}{3}\right)^2 = 1$$

3. (a) From the graph  $A = (1, 1)$  and  $B = (-1, -1)$ .

$$\text{Distance OA} = \sqrt{(1^2 + 1^2)} = \sqrt{2}$$

(b) (i)

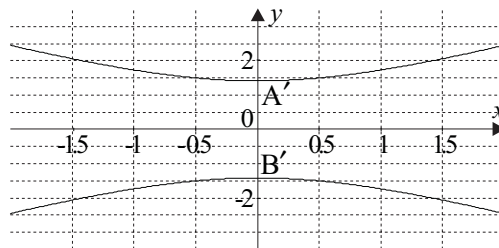

(ii)  $A' = (0, \sqrt{2})$  and  $B' = (0, -\sqrt{2})$

(iii) Eq. 1:  $\left(\frac{y}{\sqrt{2}}\right)^2 - \left(\frac{x}{\sqrt{2}}\right)^2 = 1$  or  $\frac{y^2}{2} - \frac{x^2}{2} = 1$

(c) (i)

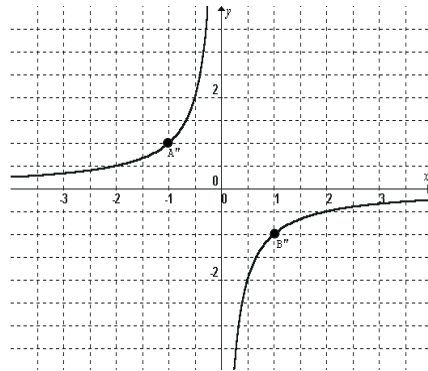

(ii)  $A'' = (-1, 1)$  and  $B'' = (1, -1)$

(iii) Eq. 2:  $y = \frac{-1}{x}$

(d) (i)

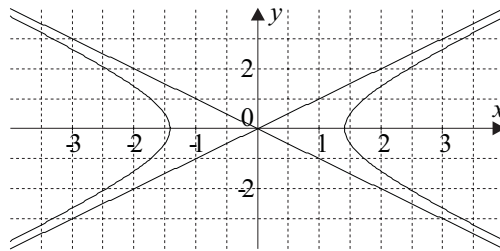

(ii) Eq. 3:  $\frac{x^2}{2} - \frac{y^2}{2} = 1$

(iii) Asymptotes:  $y = \pm x$

4. Equation a matches graph (1)

Equation b matches graph (6)

Equation c matches graph (2)

Equation d matches graph (5) .....(gradient not as steep as (4))

Equation e matches graph (4)

Equation f matches graph (3)

## Solutions to a taste of things to come

(i)  $a = 148$

$$c = 2.47$$

$$b = \sqrt{a^2 - c^2}$$

$$= \sqrt{148^2 - 2.47^2}$$

$$= 21897.9$$

$$\approx 21898$$

So the equation is:

$$\frac{x^2}{21904} + \frac{y^2}{21898} = 1$$

If you sketched this, you would find the ellipse looks almost circular.

(ii) To find the period of revolution, translate 225.6 million kilometres into astronomical

units.  $\frac{225.6}{148} \approx 1.524$

$$\tau = a^{\frac{3}{2}}$$

$$= 1.524^{\frac{3}{2}}$$

$$\approx 1.881$$

So the Mars year is about 1.881 years.

(iii) Uranus has a period of 84.02 years.

$$\tau = a^{\frac{3}{2}}$$

$$84.02 = a^{\frac{3}{2}}$$

$$a \approx 19.19$$

So Uranus is on average 19.19 astronomical units or 2840.12 million kilometres from the sun.

## Solutions to post-test

1. (i) Polar coordinates:  $R = (10, 30^\circ)$ ,  $S = (25, 135^\circ)$

(ii) Position vectors:  $\vec{r} = 10 \cos 30^\circ \vec{i} + 10 \sin 30^\circ \vec{j}$

$$\begin{aligned} &= 10 \left( \frac{\sqrt{3}}{2} \right) \vec{i} + 10 \left( \frac{1}{2} \right) \vec{j} \\ &= 5\sqrt{3} \vec{i} + 5 \vec{j} \approx 8.66 \vec{i} + 5 \vec{j} \\ \vec{s} &= 25 \cos 135^\circ \vec{i} + 25 \sin 135^\circ \vec{j} \\ &= 25 \left( -\frac{1}{\sqrt{2}} \right) \vec{i} + 25 \left( \frac{1}{\sqrt{2}} \right) \vec{j} \\ &= -\frac{25\sqrt{2}}{2} \vec{i} + \frac{25\sqrt{2}}{2} \vec{j} \approx -17.68 \vec{i} + 17.68 \vec{j} \end{aligned}$$

(iii) Displacement vector:  $\overline{RS} = \vec{s} - \vec{r}$

$$\begin{aligned} &= \begin{pmatrix} -17.68 \\ 17.68 \end{pmatrix} - \begin{pmatrix} 8.66 \\ 5 \end{pmatrix} \\ &= \begin{pmatrix} -26.34 \\ 12.68 \end{pmatrix} \\ |\overline{RS}| &= \sqrt{(-26.34)^2 + 12.68^2} \\ &= \sqrt{854.568} \approx 29.23 \\ \theta &= \tan^{-1} \left( \frac{12.68}{-26.34} \right) \\ &\approx 154.3^\circ \\ \therefore \overline{RS} &\approx (29.23, 154.3^\circ) \end{aligned}$$

(iv) The rescue boat should steer a course N  $64.3^\circ$  W (equivalent to  $154.3^\circ$  anticlockwise from East) and expect to find the yacht at a distance of approximately 29.23 nm.

2. Given:  $2y = 3x - 1$

(i) Vector form:  $y = \frac{3}{2}x - \frac{1}{2} \Rightarrow \begin{pmatrix} x \\ y \end{pmatrix} = t \begin{pmatrix} 2 \\ 3 \end{pmatrix} - \begin{pmatrix} 0 \\ \frac{1}{2} \end{pmatrix}$

(ii) Parametric form:  $\begin{cases} x = 2t \\ y = 3t - \frac{1}{2} \end{cases}$

$$\begin{aligned} \text{(iii) Mid-point theorem } \Rightarrow x_M &= \frac{x_P + x_Q}{2}, \quad y_M = \frac{y_P + y_Q}{2} \\ \Rightarrow (x, y) &= \left( \frac{2-2}{2}, \frac{2.5-3.5}{2} \right) \\ &= (0, -0.5) \quad (\text{mid-point of PQ}) \end{aligned}$$

$$3. \text{ (i) Reflection in line } y = x \Rightarrow (x, y) \rightarrow (y, x)$$

$$\Rightarrow (-3, 4) \rightarrow (4, -3) \dots\dots\dots P_a$$

$$\text{(ii) Translation of 2 (right) and 6 (down)} \Rightarrow P_b \rightarrow (-3+2, 4-6) = (-1, -2) \dots\dots\dots P_b$$

$$\text{(iii) Rotation of } 90^\circ \Rightarrow (x, y) \rightarrow (-y, x)$$

$$\Rightarrow (-3, 4) \rightarrow (-4, -3) \dots\dots\dots P_c$$

4. From the diagram:

(a) Figure A is a circle, centre (10, 3) and radius = 2

Figure B is a circle, centre (3, 10) and radius = 2

$\therefore$  A could have been **reflected** about the line  $y = x$  to obtain B, or

B could have been **translated** 7 units to the left, and 7 units vertically up.

(b) Figure A is a parabola  $y = (x - 1)^2$

Figure B is parabola A **stretched horizontally** by factor 3

$$\text{The equation of B is } y = \left( \frac{x-1}{3} \right)^2$$

(c) Figure A is a circle, centre (0, 0) and radius 1.5  $\Rightarrow x^2 + y^2 = 1.5^2$

A has been **stretched horizontally** by factor 3, and **vertically** by factor 2 to obtain B.

$$\text{The equation of B is } \left( \frac{x}{3} \right)^2 + \left( \frac{y}{2} \right)^2 = 1.5^2 \text{ or } \left( \frac{x}{4.5} \right)^2 + \left( \frac{y}{3} \right)^2 = 1$$

(d) Figure A is the curve  $y = \sin x$

Figure B has been **compressed horizontally** by a factor 3, i.e., stretched by factor  $\frac{1}{3}$

The equation of B is  $y = \sin 3x$ .

(e) Figure A is the exponential curve,  $y = e^x$

B is the **reflection** of A in the  $y$ -axis ( $x = 0$ )

B's graph is  $y = e^{-x}$ .

(f) Figure A is the hyperbola  $y = \frac{1}{x}$

B is the **rotation** of A through an angle of  $45^\circ$  clockwise (other angle rotations may be used).

The equation of B is  $x^2 - y^2 = 2$ .

5. If the Boeing 744 is within 50 nm radius. Therefore the equation is a circle with a radius 50 and the centre being the aircraft  $\Rightarrow x^2 + y^2 = 2500$ .

(\* Osserman, R. 1995, *Poetry of the Universe*, Weidenfield & Nicolson, London.)

