

Module 2

ALGEBRA AND GEOMETRY

Exercise Set 2.1

Complete the following by inserting the appropriate symbol between each LHS and RHS.

	LHS		RHS
(a)	$-1/4$		0.25
(b)	$\sqrt[3]{2}$		$\sqrt[3]{3}$
(c)	π		$22/7$
(d)	0.00012		1.2×10^{-4}
(e)	2.7		e

★ Consider the inequality $x \geq 1$. Why is this statement and the statement $1 \leq x$ equivalent?

.....

Answer:

One way to check this equivalence is to use the real number line. Defining $x \geq 1$ on the real number line gives:

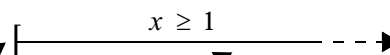
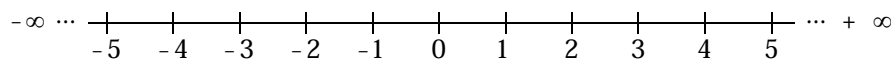

To show that the number 1 satisfies the equality use a square bracket. In some books a filled-in circle, like this, ●, is used. We will use the bracket form.

Any real number which lies on this part of the real number line satisfies the inequality

Defining $1 \leq x$ on the real number line gives the same set of numbers because 1 is the lowest possible value that x can be.

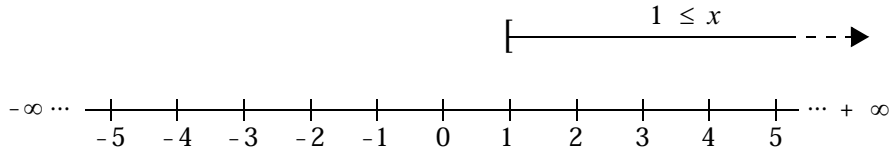

So the solution to the inequality $x \geq 1$ (or $1 \leq x$) is any real number greater than or equal to 1.



Sometimes inequalities are combined because of certain constraints on the variable of interest.

e.g. $-1 < x \leq 4$ means the solution set for x consists of all the real numbers between -1 and 4 and includes 4 .

On the real number line we get

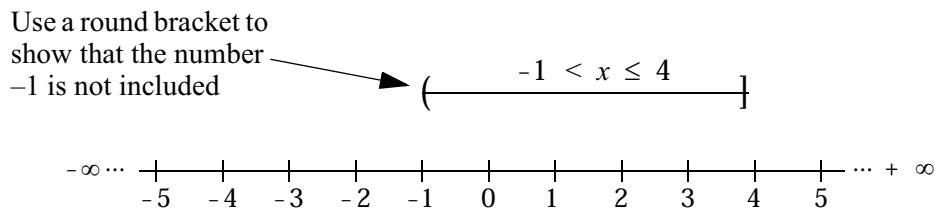

When we are representing the solution sets of variables on the real number line we are actually drawing a one dimensional graph. Later we will show the solution sets of inequalities involving two variables on two dimensional graphs (i.e. the typical XY graph of the Cartesian system).

Check now that you have grasped the idea of inequalities and their solution sets.

Exercise Set 2.2

Fill in the missing parts of the statements and give a couple of examples of rational and irrational numbers that satisfy each inequality.

1. $x \leq 4$ has the solution set ‘any real number 4’ or in interval notation, $(-\infty, 4]$ See Note 1

e.g. $-180, -\sqrt{7}, -\pi, 2, 2.41, \pi, e, \frac{10}{3}, \sqrt{2}$

2. $-2 < y$ has the solution set ‘any real number 2’ or in interval notation, $(-2, \quad)$

e.g.

3. $-\frac{1}{2} \leq p \leq 3$ has the solution set ‘.....’ or in interval notation $[\quad, \quad]$

e.g.

- ★ Why do you think inequalities such as (a) $1 < x > 3$ or (b) $1 > x < 4$ are **nonsense** and have no meaning?

.....

Answer:

- (a) 1 cannot be greater than 3

- (b) x cannot be greater than 4, nor can 4 be less than 1

If in (b) you really wanted x defined so that $1 > x$ and $x < 4$ you would need two separate inequalities. $1 > x$ means x is any number less than 1 or in interval notation $(-\infty, 1)$

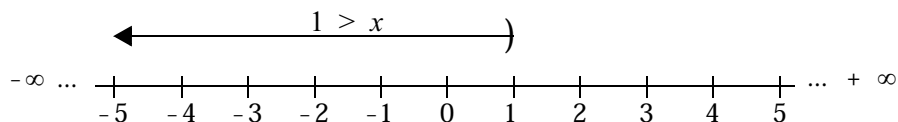

Notes

1. If a solution set extends to positive or negative infinity, a round bracket is used on the relevant end of the interval.

$x < 4$ means x is any number less than 4 or in interval notation $(-\infty, 4)$

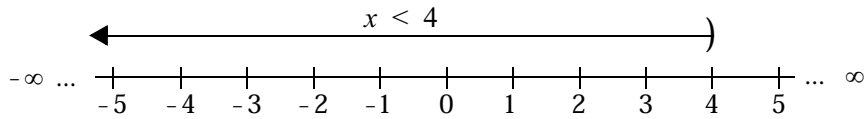

By examining these graphs you should be able to see that if **both** the inequalities are to be satisfied the solution set is $(-\infty, 1)$.

Operations on Inequalities

The same rules you use for rearranging or manipulating equations can also be used for inequalities except for the two important cases shown below.

Exception 1: Multiplying or dividing by a negative number.

Consider the equation

$$-2x = 3$$

Dividing each side by -2 gives $x = \frac{-3}{2}$

Consider the inequality

$$-2x < 3$$

Dividing each side by -2 gives

$$x > \frac{-3}{2}$$

Note the change in direction of the inequality

You can check this is true by selecting a value for x from the solution set $(-\frac{3}{2}, \infty)$ and substituting in $-2x < 3$.

e.g. say $x = 4$

when $x = 4$, $-2x < 3$ gives $-2 \times 4 < 3$ i.e. $-8 < 3$ which is valid.

However if we had not changed the sign of the inequality we would get $x < -\frac{3}{2}$ as the solution set and choosing a value from this for checking, say $x = -6$ and substituting in $-2x < 3$ gives $-2 \times -6 < 3$ i.e. $12 < 3$ which is nonsense.

So the first exception to be remembered when solving inequalities is:

If you divide (or multiply) an inequality by a negative number change the direction of the inequality.

Exception 2: Inverting two numbers

Consider the inequality

$$8 > 4$$

Inverting each side gives

$$\frac{1}{8} < \frac{1}{4}$$

Note the change
in direction of
the inequality

If you invert each side of the inequality, change the direction of the inequality.

Example 2.1: Find the solution of

$$2x + 4 \leq 3x - 3$$

Solution:

$$2x - 3x \leq -3 - 4 \quad (\text{Subtract } 3x \text{ from each side and subtract 4 from each side})$$

$$-x \leq -7 \quad (\text{Simplify})$$

$$x \geq 7 \quad (\text{Divide by } -1 \therefore \text{change of direction inequality})$$

Check solution by choosing a value for x in the interval $[7, +\infty)$ and a value not in this interval e.g. Choose say $x = 10$ and $x = 5$ See Note 1

When $x = 10$, $2x + 4 = 2 \times 10 + 4 = 24$ and $3x - 3 = 3 \times 10 - 3 = 27$ and now

LHS = 24 which is less than RHS = 27 \therefore solution is valid

When $x = 5$, $2x + 4 = 2 \times 5 + 4 = 14$ and $3x - 3 = 3 \times 5 - 3 = 12$ and now

LHS = 14 which is not less than RHS = 12 \therefore solution is not valid

Notes

1. Choosing any two values like these does not **prove** the solution is correct but it does provide a checking mechanism.

Exercise Set 2.3

Solve the following inequalities.

Express each solution set using the inequality symbols and in interval notation.

1. $2x + 4 \leq 8$
 2. $-\frac{1}{2}p > 2p + 4$
 3. $2d + 2 \leq 4d - 3$
 4. $3y - 2 \geq 4y + 6$
 5. $2y(3 - y) > (6 - y)(3 + 2y)$
 6. $|2x + 4| < 3$
-

Linear Inequalities of Two Variables

These type of inequalities frequently arise in ‘product mix’ type problems where a company wants to maximise profit (or minimise cost) for making certain products to meet the market demand but where there are **constraints** on the amount of raw materials, production capacity (machinery or labour) etc. Here’s a typical example: See Note 1

Example 2.2:

The Nabnot biscuit Company makes two types of cracker biscuits, ‘Water Biscuits’ and ‘Cheese Dippers’. Biscuit production involves three processes: mixing, cooking and packing. Each batch of ‘Water Biscuits’ requires 3 minutes mixing, 5 minutes cooking and 2 minutes to pack while each batch of ‘Cheese Dippers’ requires 3 minutes mixing, 4 minutes cooking and 3 minutes to pack. The net profit on each batch of ‘Water Biscuits’ is \$120 and on each batch of ‘Cheese Dippers’ is \$100. If the mixer, oven and packer are only available for 4 hours, 7 hours and 3 hours per day respectively, how much of each type of biscuit should be made daily in order to maximise profit?

Notes

1. Product mix problems are one type of linear programming problems. These problems are an important part of the branch of mathematics known as Operations Research.

Solution: We want to **maximise profit**, P subject to certain restrictions in the production plant.

1. Define the profit function:

$$P = 120x + 100y$$

where x is the number of batches of 'Water Biscuits' made daily and y is the number of batches of 'Cheese Dippers' made daily.

Note that x and y can never be negative as it doesn't make sense to produce a negative number of batches. Geometrically these non negativity constraints restrict the solution set to the first quadrant of the Cartesian plane.

2. Establish the constraints:

Mixing:

- one batch of 'Water Biscuits' takes 3 minutes mixing, so x batches take $3x$ minutes
- one batch of 'Cheese Dippers' takes 3 minutes mixing, so y batches take $3y$ minutes
- the mixer is available only for 4 hours (i.e. 240 minutes) per day, so the time taken for mixing the x batches of 'Water Biscuits' (i.e. $3x$) plus the time taken for mixing the y batches of 'Cheese Biscuits' (i.e. $3y$) **cannot** exceed 240 minutes.

i.e. $3x + 3y \leq 240$ _____ ①

If all the mixer time was used this inequality would become the equality $3x + 3y = 240$.

Use your computer to draw the graph of $3x + 3y = 240$. **Note:** You need to rearrange the formula as $y = 80 - 3x$. The region defined by the inequality $3x + 3y \leq 240$ is that to the lower left of the line you have just drawn. (Check this is true by selecting a couple of values for (x, y) that are in this region and algebraically showing that $3x + 3y$ is indeed less than or equal to 240.)

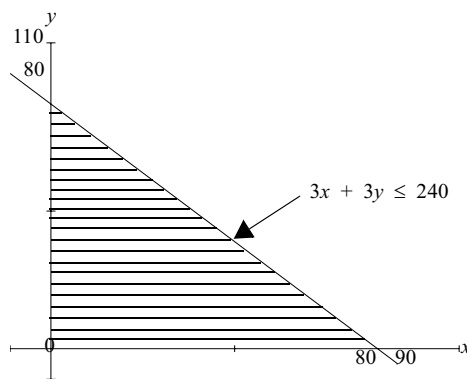

Cooking:

- one batch of ‘Water Biscuits’ takes 5 minutes cooking, so x batches take $5x$ minutes
- one batch of ‘Cheese Dippers’ takes 4 minutes cooking, so y batches take $4y$ minutes
- the oven is available only for 7 hours (i.e. 420 minutes) per day, so the time taken for cooking x batches of ‘Water Biscuits’ (i.e. $5x$) plus the time taken for cooking y batches of ‘Cheese Dippers’ (i.e. $4y$) **cannot** exceed 480 minutes.

i.e. $5x + 4y \leq 480$ _____ ②

If all the oven time was used this inequality would become the equality $5x + 4y = 420$.

Using the same scale and without clearing the screen draw the graph of $5x + 4y = 420$ You will now see that the solution set for $5x + 4y \leq 420$ includes all the points to the lower left of the line $5x + 4y = 420$. (For this particular problem it is interesting to note that the first constraint defines a region which is a subset of the region defined by the second constraint.)

Packing:

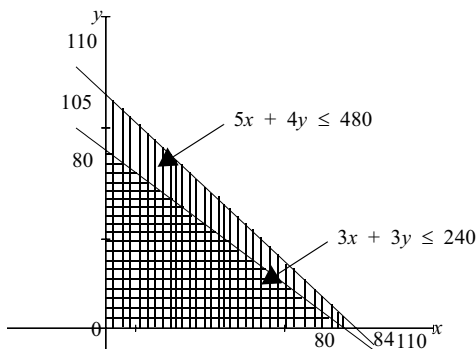

- one batch of ‘Water Biscuits’ takes 2 minutes to pack, so x batches take $2x$ minutes
- one batch of ‘Cheese Dippers’ takes 3 minutes to pack, so y batches take $3y$ minutes
- the packing line is available only for 3 hours (i.e. 180 minutes) per day, so the time taken to pack x batches of ‘Water Biscuits’ and y batches of ‘Cheese Dippers’ cannot exceed 180 minutes

i.e. $2x + 3y \leq 180$ _____ ③

Without clearing the current screen on your computer, draw the graph of $2x + 3y = 180$

Now you can see how the addition of constraint ③ has reduced the possible values of (x, y) that can be in the solution set.

The solution set of (x, y) which satisfies

$$3x + 3y \leq 240$$

$$5x + 4y \leq 480$$

$$2x + 3y \leq 180$$

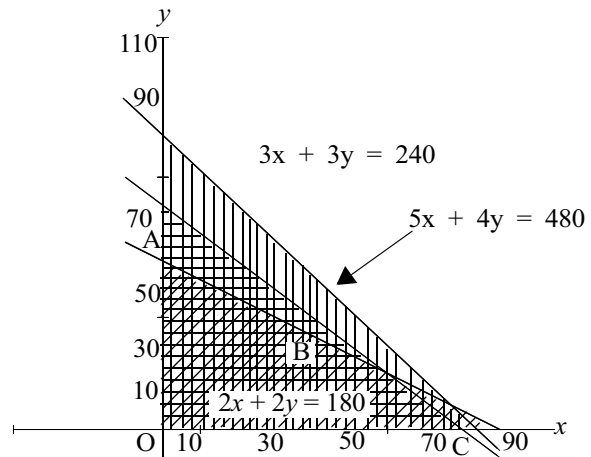

and also $x \geq 0$ and $y \geq 0$ (i.e. non negativity constraints) are all the (x, y) points in the region OABC.

3. Find optimal solution:

The final step in this type of optimisation problem to find the maximum value of the profit function in the region defined by the constraints. I will not prove it here, but it turns out that the profit function will be maximised at one of the ‘corner points’ of OABC i.e. at

O (0, 0); A (0, 60); B (60, 20) or C (80, 0) See Note 1

Substituting these values for (x, y) into $P = 120x + 100y$ gives:

At O: when $x = 0$ and $y = 0$, $P = 120 \times 0 + 100 \times 0 = \0

At A: when $x = 0$ and $y = 60$, $P = 120 \times 0 + 100 \times 60 = \$6\,000$

At B: when $x = 60$ and $y = 20$, $P = 120 \times 60 + 100 \times 20 = \$9\,200$

At C: when $x = 80$ and $y = 0$, $P = 120 \times 80 + 100 \times 0 = \$9\,600$ *optimum

So given the constraints on the system, profit will be maximised at \$9 600 per day when 80 batches of ‘Water Biscuits’ and no batches of ‘Cheese Dippers’ are made.

Check your understanding of optimising a function given certain constraints by completing the missing parts of the solution to the following problem.

Notes

1. You can find the coordinates of the corner points by solving the relevant pairs of equations or using the Zoom function on the computer graphing package.

Example 2.3:

A dietician is planning the menu for the evening meal at a hospital. Two main items, each having different nutritional content, will be served. Certain minimum daily vitamin requirements are to be met by this meal while the cost of the meal is kept as low as possible. Determine the amount of each food to be included in the meal given the following information.

	Vitamin 1 per 10g	Vitamin 2 per 10g	Vitamins 3 per 10g	Cost per 10g
Food 1	50mg	20mg	10mg	3 cents
Food 2	30mg	10mg	50mg	5 cents
Min. Daily Vitamin Requirement	290mg	200mg	210mg	

We want to **minimise cost**, subject to the daily requirement constraints and the serving size constraint.

1. Definition of Cost Function

$C = 3x + 5y$ where x is the number of 10 gram serves of Food 1
and y is the

2. Establish the non negativity constraints

$x \geq 0$
 $y \geq 0$

Establish the vitamin daily requirement constraints

Vitamin 1: $\square x + 30 \square \geq 290$ (At least 290mg of Vitamin 1 must be included)

Vitamin 2: $\square 20 x + \square \square \geq 200$ (At least 200mg of Vitamin 2 must be included)

Vitamin 3: $\square \square + \square y \geq 210$ (.....)

So the complete problem is

Minimise $C = 3x + 5y$

Under the constraints

$50x + 30y \geq 290$ _____ ①
 $20x + 10y \geq 200$ _____ ②
 $10x + 50y \geq 210$ _____ ③
 $x \geq 0 ; y \geq 0$

3. Find the set of (x, y) values that satisfies all the constraints. Use your graphing package to draw each constraint as an equality. Use the same screen for all the constraints.

$50x + 30y = 290$ _____ ① i.e. $y = \frac{29}{3} - \frac{5}{3}x$

Values of (x, y) that satisfy $50x + 30y \geq 290$ will lie to the upper right of the line $\square x + \square y = \square$ (because of the direction of the inequality).

$20x + 10y = 200$ _____ ② i.e. $y = 20 - 2x$

Values of (x, y) that satisfy $20x + 10y \geq 200$ will lie to the of the line $20\square + \square y = \square 200$

$10x + 50y = 210$ _____ ③ i.e. $y = \square - \square x$

Values of (\square, \square) that satisfy $10x + 50y \square 210$ will lie to the upper right of the line $\square x + \square y = 210$

The set of (x, y) values that satisfies all the constraints is the region (to the upper right) defined by DEF and the x and y axes

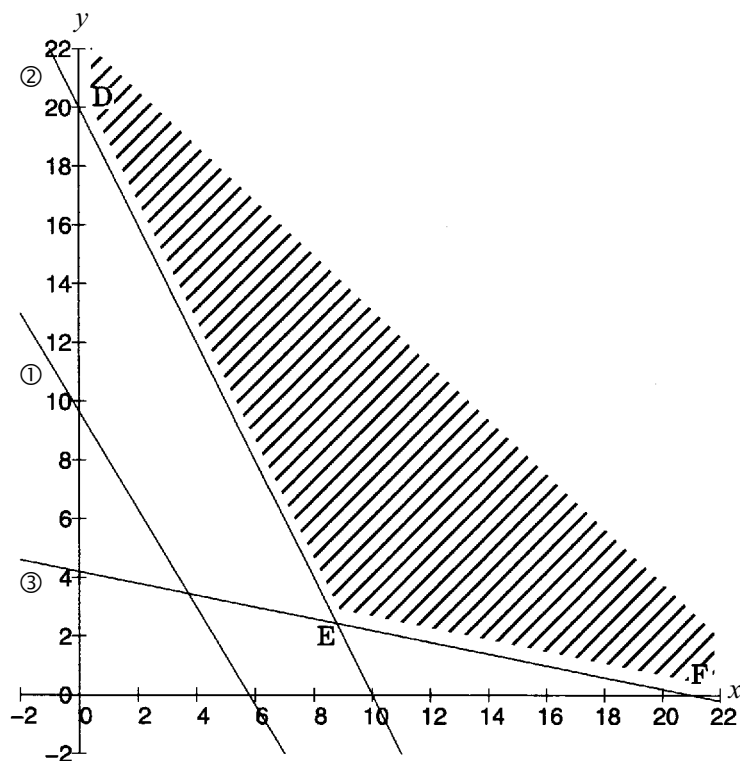

4. Find the minimum value of the cost function for this set of (x, y) values. (Recall that the optimum always occurs at a corner point of the defined region.)

$$C = 3x + 5y$$

At D: when $x = 0$ and $y = 20$, $C = 3x + 5y = 3 \times 0 + 5 \times 20 = 100$ cents

At E: when $x = 8.78$ and $\square = 2.44$, $C = 3x + 5y = 3 \times \square + 5 \times \square = 38.5$
cents
*optimum

At F: when $\square = \square$ and $y = 0$, $C = 3x + 5y = \square \times 21 + \square \times 0 = 63$
cents

5. Conclusion

So the specifications for the nutritional requirements will be satisfied when 8.8 '10 gram serves' i.e. 88 grams of Food 1 and 2.4 '10 gram serves' i.e. 24 grams of Food 2 are served. The cost of the diet will then be minimised at 38.5 cents per meal.

Exercise Set 2.4

1. Shade the region on the Cartesian Plane in which the solution to these inequalities lies.

$$\begin{aligned} \text{(a)} \quad & 4x + 5y \leq 20 \\ & 2x + 6y \leq 18 \\ & x \geq 0 \\ & y \geq 0 \end{aligned}$$

$$\begin{aligned} \text{(b)} \quad & x + y \geq 6 \\ & 10x + 2y \geq 20 \\ & y \geq 2 \\ & x \geq 0 \end{aligned}$$

2. Solve the following linear programming problem

$$\begin{aligned} \text{Maximise} \quad & P = x + y \\ \text{Subject to} \quad & 2x + y \leq 8 \\ & x + 3y \leq 9 \\ & x \geq 0 \\ & y \geq 0 \end{aligned}$$

3. A butcher wishes to blend supplies of beef and pork to make two types of sausage – regular and deluxe. The regular sausages are 20% beef, 20% pork and 60% filling while the deluxe sausages are 40% beef, 20% pork and 40% filling. The butcher makes a profit of 60¢/kg on regular sausages and 80¢/kg on deluxe sausages. If the butcher has 60kg of beef and 40kg of pork in stock, and an almost unlimited amount of filling, how many kg of each kind of sausage should be made to maximise the profit of the butcher?
4. The managers of a pension plan want to invest up to \$100 000 in 2 stocks A and B. Stock A is conservative while stock B is considered speculative. The managers agree that they should invest at most \$80 000 in stock A and at least \$12 000 in stock B. Stock A is expected to return 12% p.a. and stock B is expected to return 15% p.a. Bylaws of the pension plan require that at least 3 times as much must be invested in conservative stock as in speculative stock. How much should be invested in stock A and stock B to maximise the expected return?
-

2.2 Quadratic Equations and Completing the Square

Factorising

In the Revision Module we revised some of the features of parabolic equations and their graphs, the parabolas. The general form of a parabolic equation is:

$$y = ax^2 + bx + c \qquad \text{See Note 1}$$

When $y = 0$, we say we have a quadratic equation i.e. the general form of a quadratic equation is:

$$ax^2 + bx + c = 0$$

e.g. $x^2 + 3x + 2 = 0$

Often we are interested in factorising the LHS of such equations in order to find the solutions to the equation. Sometimes it is easy to ‘see’ the factors:

e.g. $x^2 + 3x + 2 = (x + 1)(x + 2)$.

Thus the solutions to $x^2 + 3x + 2 = 0$

i.e. $(x + 1)(x + 2) = 0$ are given when $(x + 1) = 0$ or $(x + 2) = 0$

i.e. when $x = -1$ or -2

Follow through these couple of examples, where we are working backwards using the Distributive Law in the expansion of the factors.

e.g. $(x + 4)(x + 2) = x^2 + 2x + 4x + 8 = x^2 + 6x + 8$

$6 = 2 + 4$ $8 = 4 \times 2$

e.g. $(x - 3)(x + 1) = x^2 + 1x - 3x - 3 = x^2 - 2x - 3$

$-2 = 1 - 3$ $-3 = -3 \times 1$

Note:

- the constant on the RHS is given by the product of the two numbers in the factors.
- the coefficient of x on the RHS is given by the sum of the two numbers in the factors.

Notes

1. In some books $y = ax^2 + bx + c$ is called a quadratic equation. We will use the term quadratic equation for the special case when $y = 0$.

When we are interested in a collection of terms where the highest power of x is x^2 e.g. $ax^2 + bx + c$ (i.e. we are not dealing with equations) we will describe such expressions as quadratic expressions.

Using these ideas we can now try to factorise some quadratic expressions.

Example 2.4 (a): Factorise the quadratic expression $x^2 + 4x + 4$

Solution:

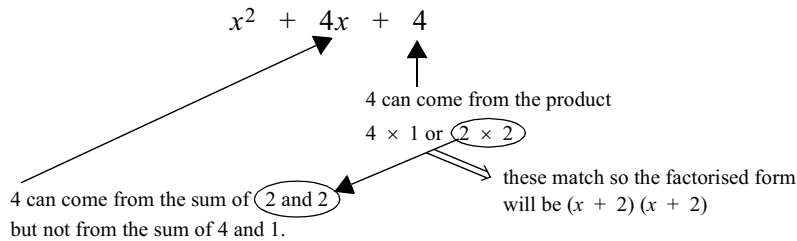

$$\therefore x^2 + 4x + 4 = (x + 2)(x + 2)$$

See Note 1

Example 2.4 (b): Factorise $x^2 - 2x - 8$

Solution:

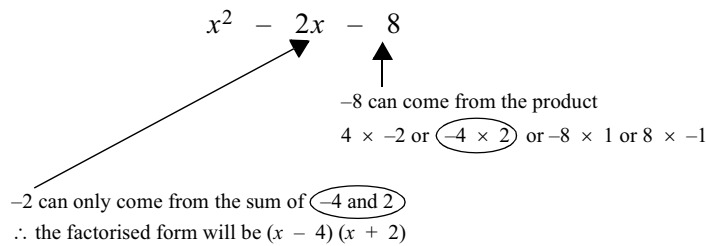

$$\text{i.e. } x^2 - 2x - 8 = (x - 4)(x + 2)$$

See Note 2

Have a look through these quadratic expressions and their factored forms and try to identify any other clues to help you when factorising.

$$\begin{aligned} x^2 + 3x + 2 &= (x + 2)(x + 1) \\ x^2 + 6x + 8 &= (x + 2)(x + 4) \\ x^2 - 2x - 3 &= (x - 3)(x + 1) \\ x^2 + 4x + 4 &= (x + 2)(x + 2) \\ x^2 - 2x - 8 &= (x - 4)(x + 2) \\ x^2 - 11x + 24 &= (x - 3)(x - 8) \\ x^2 - 5x + 6 &= (x - 2)(x - 3) \\ x^2 + 3x - 10 &= (x + 5)(x - 2) \end{aligned}$$

Is anything obvious? Look at the sign of the constant on the LHS and the sign of the constant in each factor of the RHS of each equation.

Notes

1. Expand as a check: $(x + 2)(x + 2) = x^2 + 2x + 2x + 4 = x^2 + 4x + 4$.
2. Check by expanding $(x - 4)(x + 2)$.

Examine these statements:

- ‘When the sign of the constant c is positive, both numbers in the factors always have the same sign.’
- ‘When the sign of the constant c is negative, the numbers in the factors have opposite signs.’

Check that these statements are true for all the examples above.

Furthermore we can establish which constant will be larger in **magnitude**. Look at the **sign** of the coefficient of x on the LHS in these equations.

$$\begin{aligned}x^2 - 2x - 3 &= (x - 3)(x + 1) \\x^2 - 2x - 8 &= (x - 4)(x + 2) \\x^2 + 3x - 10 &= (x + 5)(x - 2)\end{aligned}$$

Now look at the **magnitude** of the numbers in the factors on the RHS. You will see that in the factor with the ‘larger’ number, this number is the same sign as the coefficient of x in the expanded form.

So there are lots of clues to help us factorise quadratic expressions of the form

$$x^2 + bx + c \text{ (i.e. when the coefficient of } x^2 \text{ is 1)}$$

and thus solve quadratic equations of the form $x^2 + bx + c = 0$

When the coefficient of x^2 is not 1, it is easy to factor it out and then factorise the remaining expression as we have done above. If this does not produce an obvious factorisation, then the quadratic formula

$$x = \frac{-b \pm \sqrt{b^2 - 4ac}}{2a} \text{ can be used.}$$

Example 2.5 (a):(i) Factorise $3x^2 - 15x + 18$

Solution: $3x^2 - 15x + 18 = 3(x^2 - 5x + 6)$ (Forcing coefficient of x^2 to be 1 by factorising out 3 from each term)

$$3(x^2 - 5x + 6) = 3(x - 3)(x - 2)$$
 (Find factors by examination). **See Note 1**

Note: It is important to retain the 3 in the product of factors because

$$(x - 3)(x - 2) \neq 3x^2 - 15x + 18$$

(ii) Solve $3x^2 - 15x + 18 = 0$ **Solution:**

$$3x^2 - 15x + 18 = 0$$

$$3(x^2 - 5x + 6) = 0$$

$$\therefore 3(x - 3)(x - 2) = 0$$

$$\therefore (x - 3)(x - 2) = 0$$
 (Can now divide each side by 3 because RHS is zero)

$$\therefore x = 3 \text{ or } x = 2$$
 See Note 2

Example 2.5 (b):Factorise $6x^2 + 7x + 2$

Solution: $6x^2 + 7x + 2 = 6\left(x^2 + \frac{7}{6}x + \frac{2}{6}\right)$

$$= 6\left(x + \frac{2}{3}\right)\left(x + \frac{1}{2}\right)$$
 See Note 1

Check solution algebraically and graphically.

(iii) Solve $6x^2 + 7x + 2 = 0$ **Solution:**

$$6x^2 + 7x + 2 = 0$$

$$\therefore 6\left(x + \frac{2}{3}\right)\left(x + \frac{1}{2}\right) = 0$$

$$\therefore \left(x + \frac{2}{3}\right)\left(x + \frac{1}{2}\right) = 0$$
 (Can now divide each side by 6 because RHS is zero)

$$\therefore x = -\frac{2}{3} \text{ or } -\frac{1}{2}$$
 See Note 2

Notes

1. Check answer by expanding.
2. Check **each** solution by substituting in original equation or drawing the graph of the original equation. The solution should be where the graph cuts the x -axis.

Example 2.5 (c):

Solve $-3x^2 + 18x + 2 = 0$

Solution: $-3x^2 + 18x + 2 = 0$
 $\therefore -3(x^2 - 6x - 2/3) = 0$

There is no obvious factorisation of the bracketed expression so I will solve the **original** equation using the quadratic formula.

$$\begin{aligned}
 x &= \frac{-b \pm \sqrt{b^2 - 4ac}}{2a} \\
 &= \frac{-18 \pm \sqrt{18^2 - 4 \times (-3) \times 2}}{2 \times (-3)} \\
 &= \frac{-18 \pm \sqrt{348}}{-6} \\
 &= \frac{-18 \pm 2\sqrt{87}}{-6} \\
 x &= \frac{-9 + \sqrt{87}}{-3} \quad \text{or} \quad x = \frac{-9 - \sqrt{87}}{-3}
 \end{aligned}$$

$$\therefore x \approx -0.109 \quad \text{or} \quad x \approx 6.109$$

Substituting each of these values for x into the original equation (and ignoring small rounding errors) shows that the solution is correct.

Exercise Set 2.5

1. Solve each of the following equations:

(a) $x^2 - 8x = 0$

(b) $x^2 - 2x - 24 = 0$

(c) $6x^2 - x - 12 = 0$

(d) $9x^2 + 6x + 1 = 0$

(e) $2x^2 - 3 = 0$

(f) $7x^2 - 12x + 7 = 0$

(g) $-2x^2 - x + 2 = 0$

2. For each pair of roots given construct a quadratic equation of the form $ax^2 + bx + c = 0$

(a) $x = \frac{-2}{3}$ and $x = 5$

(b) Repeated root of $x = \frac{1}{3}$

(c) $x = \frac{-3 - \sqrt{2}}{4}$ and $x = \frac{-3 + \sqrt{2}}{4}$

Completing the Square

Another method of solving **any** quadratic equation when the factors are not ‘seen’ is called ‘completing the square’. It is very useful in calculus as it allows expressions to be rewritten in more amenable forms and in geometry, for example in finding the centre and radius of a circle.

Do the next exercise set before continuing on as we will be using some of the results of the questions shortly.

Exercise Set 2.6

1. Expand the following

(a) $(x + 3)^2 =$

(b) $(x + 4)^2 =$

(c) $(x + \frac{1}{2})^2 =$

(d) $(x - 2)^2 =$

(e) $(x - \frac{3}{4})^2 =$

(f) $(2x - 1)^2 =$

Now I can find an expression for $x^2 + 6x$ in terms of the square of $x + 3$.

From the exercise set you have just completed you know

$$(x + 3)^2 = x^2 + 6x + 9$$

So $(x + 3)^2 - 9 = x^2 + 6x$ {subtracting 9 from each side}

i.e. $x^2 + 6x = (x + 3)^2 - 9$

This method of expressing the sum of an ‘ x^2 ’ term and an ‘ x ’ term (such as $x^2 + 6x$) in terms of $(x + \text{some constant})^2 \pm \text{another constant}$ such as

$$x^2 + 6x = (x + 3)^2 - 9 \text{ is known as ‘completing the square’}.$$

Exercise Set 2.7

Complete the square of the sums for (b)–(f) using your expansions from Exercise 2.6 above.

(a) $x^2 + 6x = (x + 3)^2 - 9$

(b) $x^2 + 8x =$

(c) $x^2 + x =$

(d) $x^2 - 4x =$

(e) $x^2 - \frac{3}{2}x =$

(f) $4x^2 - 4x =$

★ Can you see a general pattern which links the LHS and RHS of each of the equations above?

Try to write a general rule for ‘completing the square’ of the general quadratic expression.

$x^2 + ax$

Answer: You should have written something like

$$x^2 + ax = \left(x + \frac{a}{2}\right)^2 - \left(\frac{a}{2}\right)^2 \text{ where } a \text{ is the coefficient of } x.$$



There is no need to ‘learn’ this rule.

Simply ask yourself ‘How can I get, say $x^2 + 4x$ from a squared expression such as $(x + a)^2$?’

You know $(x + a)^2 = x^2 + 2ax + a^2$

so that $2a = 4 \therefore a = 2$.

This tells you that the correct square to use **as a starting point** is $(x + 2)^2$

Now $(x + 2)^2 = x^2 + 4x + 4$, but we want an expression just for $x^2 + 4x$ so we must subtract 4 from each side, giving

$$\begin{aligned} \text{i.e.} \quad (x + 2)^2 - 4 &= x^2 + 4x \\ x^2 + 4x &= (x + 2)^2 - 4 \end{aligned}$$

OR $x^2 + ax = (x + \text{half the coefficient of } x)^2 - (\text{half the coefficient of } x)^2$

Exercise Set 2.8

Complete the following exercises. **Note:** I have done the first exercise for you. The first exercise has been done for you.

- (i) Write down the square to be used as a **starting point** for rewriting $x^2 + ax$.
- (ii) Expand this square.
- (iii) Find an expression for $x^2 + ax$ in terms of the square – a constant.
- (iv) Check each answer .

(i) (ii) (iii)

1. $x^2 + 10x$ comes from $(x + 5)^2$ and $(x + 5)^2 = x^2 + 10x + 25 \therefore x^2 + 10x = (x + 5)^2 - 25$

(iv) Checking: $(x + 5)^2 - 25 = x^2 + 10x + 25 - 25 = x^2 + 10x \checkmark$

(i) (ii)

2. $x^2 + \frac{7}{8}x$ comes from $\left(x + \frac{7}{16}\right)^2$ and $(x + \square)^2 = x^2 + 7x + \square$

(iii)

$$\therefore x^2 + \frac{7}{8}x = \left(x + \frac{7}{16}\right)^2 - \square$$

(iv) Checking: $\left(x + \frac{7}{16}\right)^2 - \frac{49}{256} = x^2 + \frac{7}{8}x + \frac{49}{256} - \frac{49}{256} = x^2 + \frac{7}{8}x \checkmark$

(i) (ii)

3. $2x^2 + x$ comes from $2\left\{\left(x + \frac{1}{4}\right)^2\right\}$ and $2\left\{\left(\square + \frac{1}{4}\right)^2\right\} = 2\left\{x^2 + \square + \frac{1}{16}\right\}$

(iii)

$$\therefore 2x^2 + x = 2\left\{\left(\square + \square\right)^2 - \square\right\} = 2\left(x + \frac{1}{4}\right)^2 - \frac{1}{8}$$

(iv) Checking: $2\left(\dots\right)^2 - \square = 2\left(\dots\right) - \frac{1}{8} = 2x^2 + x \checkmark$

(i)

4. $kx^2 + x$ comes from $k\left\{\left(x + \frac{1}{2k}\right)^2\right\}$ and

(iv) Checking:

5. $x^2 - 8x$ comes from $(x - 4)^2$ and $(x - 4)^2 = \square - \square + \square \therefore x^2 - 8x = \dots\dots\dots$

Checking:

6. $x^2 - 9x$ comes from $\left(x - \frac{9}{2}\right)^2$ and $\left(x - \frac{9}{2}\right)^2 = \dots\dots\dots \therefore x^2 - 9x = \dots\dots\dots$

Checking:

7. $x^2 - ax$ comes from and = $\therefore x^2 - ax = \dots\dots\dots$

Checking:

Completing the square can also be used for converting quadratic expressions of the form $x^2 + ax + b$ where a and b are both constants.

Example 2.6 (a): Convert $x^2 + 4x - 2$ to the form of a perfect square \pm some constant.

Solution: We know from the work above that

$$x^2 + 4x = (x + 2)^2 - 4$$

$$\therefore x^2 + 4x - 2 = \left\{\left(x + 2\right)^2 - 4\right\} - 2$$

$$= (x + 2)^2 - 6$$

Checking: $(x + 2)^2 - 6 = x^2 + 4x + 4 - 6 = x^2 + 4x - 2 \checkmark$

Example 2.6 (b): Convert $x^2 + 10x + 22$ to a perfect square \pm some constant

Solution: $x^2 + 10x + 22 = \underbrace{\left\{\left(x + 5\right)^2 - 25\right\}}_{x^2 + 10x} + 22 = (x + 5)^2 - 3$

Checking: $(x + 5)^2 - 3 = x^2 + 10x + 25 - 3 = x^2 + 10x + 22 \checkmark$

So for a sum of the form $x^2 + ax + b$, the first step is to consider just the x^2 term and the x term and to complete the square for their sum; the second step is to include the b term; and the third step is to simplify by gathering the constants together. The last step, **as always**, is to check your solution by expanding your answer.

Example 2.7 (a): Solve the quadratic equation $x^2 + \frac{3}{8}x - 41 = 0$ by completing the square.

Check your answer.

Solution:

Step 1: $x^2 + \frac{3}{8}x$ comes from $\left(x + \frac{3}{16}\right)^2$ and $\left(x + \frac{3}{16}\right)^2 = x^2 + \frac{3}{8}x + \frac{9}{256}$

$$\therefore x^2 + \frac{3}{8}x = \left(x + \frac{3}{16}\right)^2 - \frac{9}{256}$$

Step 2: $\therefore x^2 + \frac{3}{8}x - 41 = \left(x + \frac{3}{16}\right)^2 - \frac{9}{256} - 41$

Step 3: $\therefore x^2 + \frac{3}{8}x - 41 = \left(x + \frac{3}{16}\right)^2 - \frac{10\,505}{256}$

Step 4: Checking:

$$\begin{aligned} \left(x + \frac{3}{16}\right)^2 - \frac{10\,505}{256} &= x^2 + \frac{3}{8}x + \frac{9}{256} - \frac{10\,505}{256} \\ &= x^2 + \frac{3}{8}x - \frac{10\,496}{256} \\ &= x^2 + \frac{3}{8}x - 41 \quad \checkmark \end{aligned}$$

Now we know that $x^2 + \frac{3}{8}x - 41 = 0$

$$\therefore \left(x + \frac{3}{16}\right)^2 - \frac{10\,505}{256} = 0$$

$$\therefore x + \frac{3}{16} = \pm \sqrt{\frac{10\,505}{256}}$$

$$\therefore x = \frac{-3}{16} \pm \sqrt{\frac{10\,505}{256}}$$

$$= \frac{-3}{16} \pm \sqrt{\frac{10\,505}{16}}$$

$$= \frac{-3 \pm \sqrt{10\,505}}{16}$$

$$\therefore x \approx 6.218 \quad \text{and} \quad x \approx -6.593$$

We can check these solutions algebraically or graphically.

$$\text{When } x \simeq 6.218, \quad x^2 + \frac{3}{8}x - 41 = 6.218^2 + \frac{3}{8} \times 6.218 - 41 \simeq 0 \quad \checkmark$$

$$\text{When } x \simeq -6.593, \quad x^2 + \frac{3}{8}x - 41 = (-6.593)^2 + \frac{3}{8} \times (-6.593) - 41 \simeq 0 \quad \checkmark$$

Graphically, if the solutions are correct the graph of $y = x^2 + \frac{3}{8}x - 41$ will cut the x -axis at $x \simeq -6.593$ and at $x \simeq 6.218$. This is indeed the case as shown in the graph below.

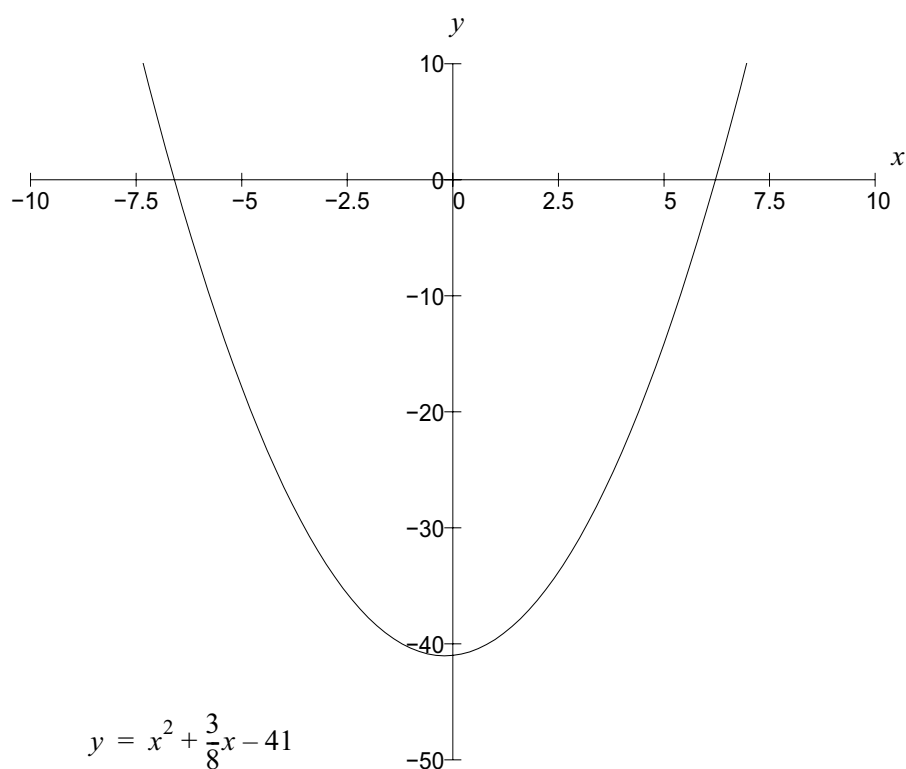

Example 2.7 (b):

Fill in the boxes in this example.

Solve the quadratic equation $3x^2 + 6x - 2 = 0$ by completing the square. Check your answer.

$$3x^2 + 6x - 2 = 3\{x^2 + \boxed{}\} - 2 \quad (\text{Force the coefficient of } x^2 \text{ to be 1 by factoring})$$

Step 1: $3\{x^2 + 2x\}$ comes from $3\{(x + \boxed{})^2\}$ and $3\{(x + 1)^2\} = 3\{\boxed{} + \boxed{} + \boxed{}\}$

$$\therefore 3\{x^2 + 2x\} = 3\{(x + 1)^2 - 1\}$$

Step 2: $\therefore 3x^2 + 6x - 2 = 3\{x^2 + 2x\} - 2 = 3\{(x + 1)^2 - 1\} - \boxed{}$

Step 3: $3x^2 + 6x - 2 = 3(x + 1)^2 - 3 - 2$

$$= 3(x + 1)^2 - \boxed{}$$

Step 4: Checking:

$$\begin{aligned} 3(x + 1)^2 - 5 &= 3(x^2 + 2x + 1) - 5 \\ &= 3x^2 + 6x + 3 - 5 \\ &= 3x^2 + 6x - 2 \quad \checkmark \end{aligned}$$

Now we know that $3x^2 + 6x - 2 = 0$

$$\therefore 3(x + 1)^2 - 5 = \boxed{}$$

$$\therefore (x + 1)^2 = \boxed{}$$

$$\therefore x = -1 \pm \sqrt{\frac{5}{3}}$$

$$\therefore x \approx \boxed{} \text{ and } x \approx \boxed{}$$

Checking algebraically:

When $x = 0.291$, $3x^2 + 6x - 2 = 3 \times 0.291^2 + 6 \times 0.291 - 2 \approx 0 \quad \checkmark$

When $x = -2.291$, $3x^2 + 6x - 2 = 3 \times (-2.291)^2 + 6 \times (-2.291) - 2 \approx 0 \quad \checkmark$

Checking graphically:

Draw the graph of $y = 3x^2 + 6x - 2$ and zoom in on the points where the graph cuts the x -axis.

Exercise Set 2.9

- (i) Complete the square in the following quadratic expressions.
 - (ii) Check each answer by expanding your solutions.
 - (iii) Make each expression the LHS of the general quadratic equation $ax^2 + bx + c = 0$
 - (iv) Solve each equation using the result from (i).
 - (v) Check your solutions.
1. $x^2 + 8x - 4$
 2. $x^2 + 4x + 9$
 3. $-8x^2 + 16x - 4$
 4. $-3x^2 + 6x + 4$
-

2.3 Functions

Polynomials

The most commonly used functions in the many applications of mathematics are the polynomial functions. Polynomial functions are often used to approximate complicated functions because they are easy to add, subtract, multiply etc. and examine using calculus. Generally they are said to be ‘well-behaved’.

Do the next Exercise Set before proceeding with the text so that you are familiar with the graphs of some typical polynomials.

Exercise Set 2.10

Use your graphing package to draw the graphs of each of the following:

1. $P_1(x) = x + 4$

See Note 1

2. $P_2(x) = 8x^2 + 2x + 4$

3. $P_3(x) = 2x^3 + x^2 + 2x$

4. $P_4(x) = x^4 + 3x^2 - 4x + 1$

Make sure that you note the following:

All of these functions are polynomials and thus produce smooth curves with no corners or breaks.

$P_1(x) = x + 4$ is a straight line as the highest power of x in this equations is x^1

$P_2(x) = 8x^2 + 2x + 4$ is a curve (as are all the other graphs). The highest power of x in this equation is x^2 and thus it is a parabola. It has only one turning point.

$P_3(x) = 2x^3 + x^2 + 2x$ is a curve with no turning points. The highest power of x in this equation is x^3 . This equation is called a cubic.

$P_4(x) = x^4 - 12x^2 + 3x + 4$ is a curve with two turning points. The highest power of x in this equation is x^4 . It is also a cubic. A cubic has, **at most**, two turning points.

In other mathematics that you have done you will have used and operated on polynomial functions without perhaps realising their special characteristics. Polynomials have the following characteristics:

- It can be a sum of one or more algebraic terms e.g. $P(x) = 3$; $P(x) = x^2$;
 $P(x) = x^2 - 2x$; $P(x) = x^4 - 5y^2$; $P(x) = 2x^2 - 4xy + 3$ See Note 2
 - the variables in any term **cannot** have a negative or fractional power
e.g. $f(x) = \sqrt{x}$; $f(x) = 2x^2 + 3x^4 - x^{3/2}$; $f(x) = yx^{-1} + 3x^2$ are **not** polynomials.
-

Notes

1. $P_1(x)$ is read as 'P one of x'. I have used P instead of f for these functions just to emphasise that they are all polynomials. You can call the functions whatever name you choose.
2. Polynomials can involve more than one variable e.g. $f(x) = xy^2 + 2y + x^3y$ is also a polynomial.

You are already familiar with factorising quadratic equations by observation or using the quadratic formula. There are also formulae for cubic and quartic equations but they are quite complicated and we will not be using them. However, often we need to factorise such higher degree polynomials.

For a cubic equation (i.e. highest degree of x is x^3) of the general form

$$P(x) = ax^3 + bx^2 + cx + d \text{ where } a, b, c \text{ and } d \text{ are constants,}$$

we shall adopt the following method.

Step 1: Set the polynomial equal to zero

See Note 1

Step 2: Use trial and error (with ‘intelligent’ guessing) to find some value of x that now satisfies the equation (i.e. find one ‘root’)

See Note 2

Step 3: Use this solution to write the equation as a product of a linear factor and a lower degree polynomial

Step 4: Use ‘long division’ to divide this factor into the equation (For a cubic, the result will be a quadratic)

Step 5: Factorise the resulting lower degree polynomial using an appropriate method

Step 6: Check solution by multiplying out the factors.

Example 2.8: Factorise $P(x) = x^3 - 3x^2 - 10x + 24$

Solution:

Step 1: Let $x^3 - 3x^2 - 10x + 24 = 0$ and look for roots of this equation

Step 2: Try $(x - 1)$ as a factor. {If $(x - 1)$ is a factor, $x = 1$ must satisfy the equation}

When $x = 1$, $x^3 - 3x^2 - 10x + 24 = 1 - 3 - 10 + 24$ which does **not** equal 0
 $\therefore x = 1$ **is not** a solution $\Rightarrow (x - 1)$ **is not** a factor.

Trying $(x + 1)$ does not seem particularly promising

See Note 3

Try $(x - 2)$ as a factor. {If $(x - 2)$ is a factor, $x = 2$ must satisfy the equation}.

When $x = 2$, $x^3 - 3x^2 - 10x + 24 = 0 \therefore x = 2$ **is** a solution $\Rightarrow (x - 2)$ **is** a factor.

Step 3: Thus $x^3 - 3x^2 - 10x + 24 = (x - 2) \times$ (some quadratic expression)

Notes

1. This means we are looking for where $P(x)$ cuts the x -axis.
2. The value of x where a function cuts the x -axis is known as a **root** or **zero** of the function.
3. ‘Intelligent’ guessing.

Step 4: Stages in the long division

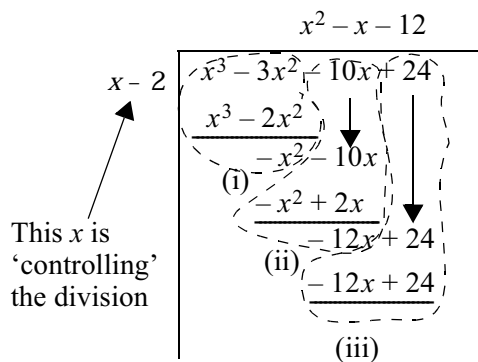

- (i) • Ask yourself ‘how many times does x divide into x^3 ’ i.e. find $\frac{x^3}{x}$. The answer is x^2 .
- Now multiply x^2 by each of the terms in the dividing factor i.e. $x^2 \times -2$ gives $-2x^2$ and $x^2 \times x$ gives x^3 .
- Write these under the corresponding powers of x .
- Subtract as in ordinary long division.
- (ii) • ‘Bring down’ the next term ($-10x$).
- Ask yourself ‘how many times does x divide into $-x^2$ ’ i.e. find $\frac{-x^2}{x}$. The answer is $-x$.
- Now multiply $-x$ by each of the terms in the dividing factor. i.e. $-x \times -2$ gives $2x$ and $-x \times x$ gives $-x^2$.
- Write these under the corresponding powers of x .
- Subtract as in ordinary long division.
- (iii) • ‘Bring down’ the next term ($+24$).
- Ask yourself ‘how many times does x divide into $-12x$ ’ i.e. find $\frac{-12x}{x}$. The answer is -12 .
- Now multiply -12 by each of the terms in the dividing factor. i.e. -12×-2 gives 24 and $-12 \times x$ gives $-12x$.
- Write these under the corresponding powers of x .
- Subtract as in ordinary long division.

Thus $x^3 - 3x^2 - 10x + 24 = (x - 2)(x^2 - x - 12)$ {the product of a linear factor and a quadratic factor}

Step 5: $x^2 - x - 12 = (x - 4)(x + 3)$
 $\therefore x^3 - 3x^2 - 10x + 24 = (x - 2)(x - 4)(x + 3)$ {the product of three linear factors}

(Graphically we now know that $P(x)$ cuts the x axis at $x = 2, 4$ and -3)

Step 6: Checking: $(x - 2)(x - 4)(x + 3)$ See Note 1

$$= (x^2 - 4x - 2x + 8)(x + 3)$$

$$= (x^2 - 6x + 8)(x + 3)$$

$$= x^3 + 3x^2 - 6x^2 - 18x + 8x + 24$$

$$= x^3 - 3x^2 - 10x + 24$$

$$= P(x) \checkmark$$

Notes

1. The solutions of the equation $x^3 - 3x^2 - 10x + 24 = 0$ are $x = 2, 4$ and -3 . It is important to realise that these are the solutions of $P(x)$ only when $P(x) = 0$.

- ✪ Use your computer to draw the graph of $P(x) = x^3 - 3x^2 - 10x + 24$. Use the Zoom function to find where the graph cuts the x axis. Verify that the roots are $x = 2, 4$ and -3 .

Note that generally, the number of linear factors of a polynomial equals the degree of the polynomial. In the example above, the degree of the polynomial is 3 and there are 3 linear factors. You will recall from the earlier work on quadratics that these may be the same e.g.

$$P(x) = x^2 + 4x + 4 = (x + 2)(x + 2)$$

Exercise Set 2.11

1. Solve the following equations. Check your answers algebraically

(a) $x^3 + 4x^2 - x - 4 = 0$

(b) $x^3 - 4x^2 + x + 6 = 0$

(c) $2x^3 - 2x^2 - 8x + 8 = 0$

(d) $t^3 + 3t^2 - 6t - 6 = 2$

(e) $y^3 + 6 = 2y^2 + 5y$

2. Find the roots of the following polynomials graphically using your computer package.

(a) $P(x) = x^3 + 4x^2 - x - 4$

(b) $P(x) = 2x^3 - 2x^2 - 8x + 8$

(c) $P(x) = 3x^2 + 2x - 1$

(d) $P(x) = x^3 + 2x^2 - x - 2$

Rational Functions

It's obvious that polynomials of the general form

$$y = a_0 + a_1x + a_2x^2 + a_3x^3 + \dots + a_nx^n \text{ are functions.} \quad \text{See Note 1}$$

When one polynomial is divided by another polynomial we say that the quotient is a **rational function**. When the degree of the numerator polynomial is **lower** than the degree of the denominator polynomial the rational function is said to be a **proper** rational function; otherwise it is an **improper** rational function. See Note 2

Proper rational functions may be written as the sum of simpler algebraic expressions called **partial fractions**. Being able to express proper rational functions as partial fractions is important for calculus.

Before moving on to expressing rational functions as partial fractions complete the next Exercise Set so that you can check your understanding of rational functions.

Notes

1. a_0, a_1, \dots, a_n are constants.
2. You can compare these terms with proper fraction (e.g. $\frac{1}{2}, \frac{-4}{13}$) and improper fraction (e.g. $\frac{13}{12}, \frac{-12}{5}$).

Exercise Set 2.12

1. For each of the following quotients,

- (i) decide if the quotient is a rational function or not
- (ii) if rational, state if it is proper or improper
- (iii) if rational, determine for what values of x the function is **not defined**. (If you have trouble with this, draw the graphs of the rational functions.)

Quotient	Rational Function	Improper or Improper	Not defined
(a) $\frac{x^2}{x-1}$	Yes (Ratio of 2 polynomials)	Improper (Degree of numerator polynomial is higher than that of denominator polynomial)	For $x = 1$
(b) $\frac{\sqrt{x}}{x-1}$	No (Fractional power in numerator function \therefore not a polynomial)		
(c) $\frac{x}{x^2-5x+6}$			
(d) $\frac{x^2-1}{x(x-1)^2}$			
(e) $\frac{7x+3}{x^3-2x^2-3x}$			
(f) $\frac{x^3+3x-4}{x-2}$			
(g) $\frac{\cos x}{x^2+x-1}$			

★ To express a rational function as a sum of partial fractions we need to ensure that it is proper. Can you think of a way to make $\frac{x^2}{x-1}$ into a simple sum involving a proper rational function?

[Hint: Recall the work on algebraic long division.]

.....

Answer: If we divide $(x - 1)$ which is a linear factor into x^2 we will get an expression which is one degree lower.

$$\begin{array}{r}
 x + 1 \\
 x - 1 \overline{) x^2} \\
 \underline{x^2 - x} \\
 x - 1 \\
 \underline{x - 1} \\
 0
 \end{array}$$

Now we have a remainder

So $\frac{x^2}{x-1} = (x + 1)$ plus $\frac{1}{x-1}$ remainder

See Note 1

i.e. $\frac{x^2}{x-1} = (x + 1) + \left(\frac{1}{x-1}\right)$

↑
This is simple

↑ This is now a proper rational function which can be decomposed into partial fractions.

If you are not convinced that this result is correct put the RHS on the common denominator of $(x - 1)$ and simplify.

This is a very important concept so do not proceed if you are not confident of your understanding.

Notes

1. Recall from arithmetic

$$3 \overline{) 146}$$

i.e. $\frac{146}{3} = 48$ plus $\frac{2}{3}$ remainder.

Exercise Set 2.13

Write the following improper rational functions as sums involving proper rational functions. Check each answer by putting the terms in the sum on a common denominator and simplifying.

1. $\frac{x^2 + 4x}{x + 2}$

2. $\frac{x^3 - 2x + 1}{x^2 - 4}$

3. $\frac{x^3 - 3x}{x^2 - 2x}$ [Hint: Write $x^3 - 3x$ as $x^3 + 0x^2 - 3x$]

4. $\frac{7x^3 + 3}{x^3 - 2x^2 - 3x}$

5. $\frac{x^2 - 8}{3x^2 - 12x + 6}$ [Hint: Take 3 out as a common factor in the denominator first]

Now that you can change improper rational fractions into sums involving proper rational functions it is time to look at the important algebraic technique of partial fractions. This technique will need your close attention, so it is important that you **work** through all the calculations and do all of the exercises.

Decomposition of Proper Rational Functions into Partial Fractions

Because we can always write an improper rational function as a sum involving a proper rational function we will focus here just on the decomposition of proper rational functions.

When a rational function is decomposed (separated) into partial fractions, the result is an **identity**.

See Note 1

e.g. $\frac{x + 3}{-2x^2 + 3x + 2} \equiv \frac{1}{2 - x} + \frac{1}{2x + 1}$

See Note 2

Notes

1. An identity is a statement which is true for all permissible values of x .
2. In this identity x cannot be 2 or $-\frac{1}{2}$.

★ Show that $\frac{x + 3}{-2x^2 + 3x + 2} \equiv \frac{1}{2 - x} + \frac{1}{2x + 1}$ is correct by

(a) putting the fractions on the RHS of the identity on a common denominator and then expanding

(b) using the computer package to draw the graph of $f(x) = \frac{1}{2 - x} + \frac{1}{2x + 1}$ and then superimposing the graph of $\frac{x + 3}{-2x^2 + 3x + 2}$

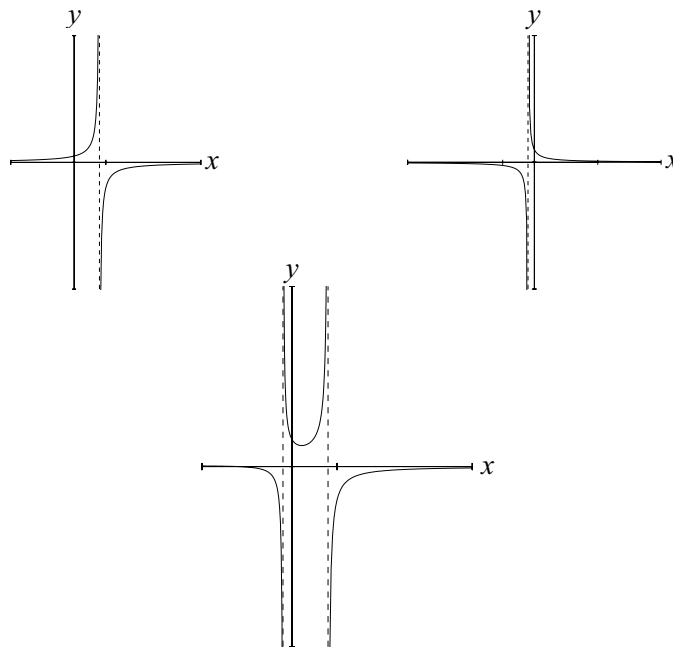

In general we will let $P(x)$ be the polynomial of the numerator and $Q(x)$ be the polynomial of the denominator of our rational function. (Note that $Q(x)$ cannot be zero). So in the above example $P(x) = x + 3$ and $Q(x) = -2x^2 + 3x + 2$.

From the decomposition of $\frac{x + 3}{-2x^2 + 3x + 2}$ into $\frac{1}{2 - x} + \frac{1}{2x + 1}$ and your solution to (a) above, you can see that the factors of the denominator play a crucial role in the decomposition. There are three cases to consider:

1. If $Q(x)$ can only be expressed as the product of **linear factors** then the partial fractions will have numerators that are **numbers**.

e.g.
$$\frac{x+3}{-2x^2+3x+2} = \frac{x+3}{(2-x)(2x+1)} = \frac{1}{2-x} + \frac{1}{2x+1}$$

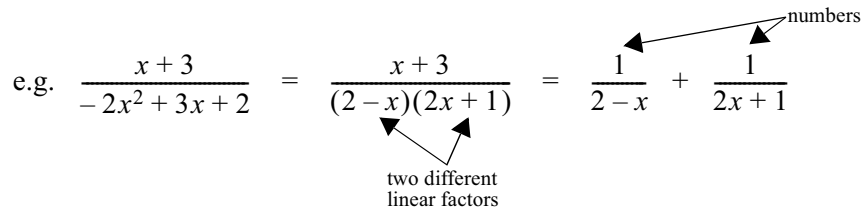

If $Q(x)$ can only be expressed as the product of a **linear factor and an irreducible quadratic factor** then the partial fraction with the linear factor of $Q(x)$ as the denominator will have a **number** as the numerator, and the partial fraction with the irreducible quadratic factor of $Q(x)$ as the denominator will have a numerator which is a **polynomial of degree 1**. See Note 1

e.g.
$$\frac{4x^2-7x+3}{x^3+2x^2-x+2} = \frac{4x^2-7x+3}{(2-x)(1+x^2)} = \frac{1}{2-x} + \frac{1-3x}{1+x^2}$$

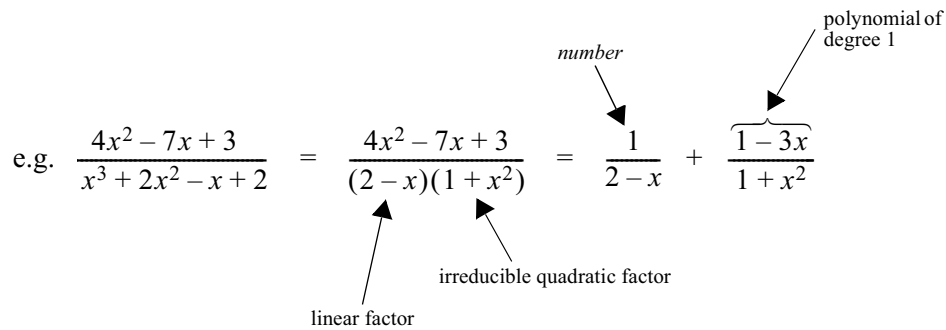

If $Q(x)$ has **repeated factors** then we must include a partial fraction for each **power** of the repeated factor.

e.g.
$$\frac{1}{x^3-2x^2+x} = \frac{1}{x((x-1)(x-1))} = \frac{1}{x} + \frac{-1}{(x-1)} + \frac{1}{(x-1)^2}$$

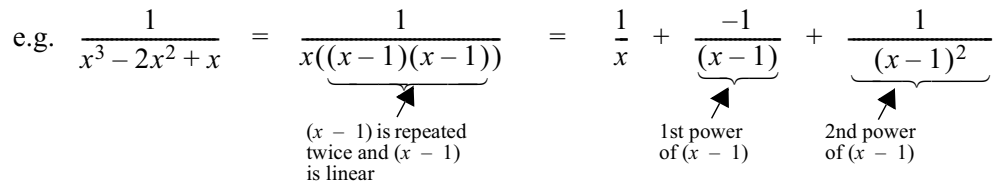

e.g.
$$\frac{x^3-1}{x^4+8x^2+16} = \frac{x^3-1}{(x^2+4)(x^2+4)} = \frac{x}{x^2+4} + \frac{-4x-1}{(x^2+4)^2}$$

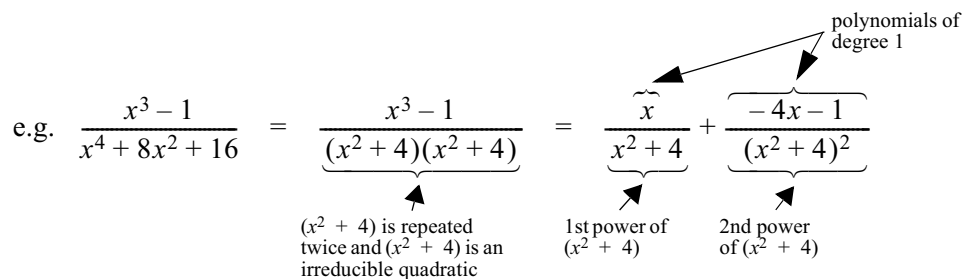

Notes

1. An irreducible quadratic is one which cannot be factorised into linear factors eg $x^2+1=0$.

The procedure for the decomposition of rational functions into partial fractions is as follows.

Step 1: Factorise the denominator $Q(x)$ into a product consisting of linear factors and/or quadratic factors.

Note if any factor is repeated.

Step 2: Write the numerators of the partial fractions in general terms and form an identity.

Step 3: Clear fractions from each side of the identity; expand brackets; simplify.

Step 4: Equate coefficients of each power of x on each side of the identity. (This is valid because the mathematical statement is an identity.)

Step 5: Solve for constants.

Step 6: Substitute for unknowns in original partial fractions.

Step 7: Check that the partial fractions when placed on a common denominator and ‘tidied-up’ yield the original rational function.

Example 2.9: Decompose $\frac{x+3}{-2x^2+3x+2}$ into partial fractions.

Step 1: Check that $P(x)$ and $Q(x)$ are indeed polynomials and that $P(x)$ does not have higher degree than $Q(x)$. As this is the case factorise the denominator. You can do this factorisation by inspection or by using the quadratic formula.

$$Q(x) = -2x^2 + 3x + 2 = (2 - x)(2x + 1)$$

Therefore we have the product of two **non-identical linear** factors.

Step 2: $\frac{P(x)}{Q(x)} = \frac{x+3}{-2x^2+3x+2} = \frac{x+3}{(2-x)(2x+1)} \equiv \frac{A}{(2-x)} + \frac{B}{(2x+1)}$ where A and B are the numbers to be determined.

$$\text{Step 3: } \frac{x+3}{(2-x)(2x+1)} \equiv \frac{A}{(2-x)} + \frac{B}{(2x+1)}$$

Clear fractions on RHS by multiplying through by $(2-x)(2x+1)$ (i.e. put rational functions on RHS on a common denominator)

$$\frac{x+3}{(2-x)(2x+1)} \times (2-x)(2x+1) = \frac{A}{(2-x)} \times (2-x)(2x+1) + \frac{B}{(2x+1)} \times (2-x)(2x+1)$$

$$\therefore x + 3 = A(2x + 1) + B(2 - x)$$

Expanding brackets on RHS

$$\therefore x + 3 = 2Ax + A + 2B - Bx$$

Gathering terms with same powers of x together

$$\therefore x + 3 = (2Ax - Bx) + (A + 2B)$$

$$\therefore x + 3 = (2A - B)x + (A + 2B)$$

Step 4: Equating coefficients of each power of x on each side of the identity

Coefficient of x^1 on LHS is 1; coefficient of x^1 on RHS is $(2A - B)$

$$\therefore 1 = 2A - B$$

Coefficient of x^0 (i.e. the value of the constant) on LHS is 3; coefficient of x^0 on RHS is $(A + 2B)$

$$\therefore 3 = A + 2B$$

Step 5: Solving simultaneously for A and B in

$$\begin{aligned} 1 &= 2A - B \\ 3 &= A + 2B \end{aligned}$$

yields $A = 1$ and $B = 1$

$$\text{Step 6: } \frac{x+3}{(2-x)(2x+1)} \equiv \frac{A}{2-x} + \frac{B}{2x+1} = \frac{1}{2-x} + \frac{1}{2x+1}$$

Step 7: Check solution

$$\frac{1}{2-x} + \frac{1}{2x+1} = \frac{1(2x+1) + 1(2-x)}{(2-x)(2x+1)}$$

$$= \frac{2x+1+2-x}{(2-x)(2x+1)}$$

$$= \frac{x+3}{(2-x)(2x+1)}$$

$$= \frac{x+3}{4x+2-2x^2-x}$$

$$= \frac{x+3}{-2x^2+3x+2}$$

which is the original rational function ✓

This is not a very easy section of work but it is important later on for calculus. Work carefully through the next examples filling in the blanks and the boxes. As you gain confidence you will be able to omit some steps.

Example 2.10: Complete the decomposition of $\frac{4x^2 - 7x + 3}{-x^3 + 2x^2 - x + 2}$ into partial fractions

Solution:

Step 1: Denominator, $Q(x)$ is $-x^3 + 2x^2 - x + 2$

See Note 1

Through trial and error and intelligent guessing I find $(2 - x)$ is a factor of $-x^3 + 2x^2 - x + 2$.

Use long division to find other factor.

$$2 - x \overline{) -x^3 + 2x^2 - x + 2}$$

$\therefore Q(x) = -x^3 + 2x^2 - x + 2 = (2 - x)(\dots\dots\dots)$

Note no repeated factors but second factor is an $\dots\dots\dots$ quadratic

Step 2: $\frac{P(x)}{Q(x)} = \frac{4x^2 - 7x + 3}{-x^3 + 2x^2 - x + 2} = \frac{4x^2 - 7x + 3}{(2 - x)(1 + x^2)} \equiv \frac{A}{2 - x} + \frac{\overbrace{Bx + C}^{\text{polynomial of degree 1}}}{1 + x^2}$

where A, B and C are to be determined

Step 3: Multiply through by $(2 - x)(1 + x^2)$ to clear fractions

$$\frac{4x^2 - 7x + 3}{(2 - x)(1 + x^2)} \times (2 - x)(1 + x^2) = \frac{A}{(2 - x)} \times (2 - x)(1 + x^2) + \frac{(Bx + C)}{1 + x^2} \times (2 - x)(1 + x^2)$$

$\therefore 4x^2 - 7x + 3 = A \times (\dots\dots\dots) + (Bx + C)(\dots\dots\dots)$

Expanding brackets on RHS

$$4x^2 - 7x + 3 = A + Ax^2 + 2Bx - Bx^2 + 2C - Cx$$

Gathering terms with same powers of x together

$$4x^2 - 7x + 3 = (\quad) x^2 + (\quad) x + (A + 2C)$$

Notes

1. A negative coefficient for x^3 indicates that at least one factor as a $-x$ term.

Step 4: Coefficient of x^2 on LHS is ; coefficient of x^2 on RHS is $(A - B)$

Coefficient of x^1 on LHS is ; coefficient of x^1 on RHS is $(2B - C)$

Coefficient of x^0 on LHS is ; coefficient of x^0 on RHS is $(A + 2C)$

Step 5: Equating coefficients of powers of x yields

$$\begin{aligned} 4 &= A - B \\ -7 &= 2B - C \\ 3 &= A + 2C \end{aligned}$$

Solution of these three equations is shown on page 2.45

Solving simultaneously gives

$$A = \text{} \quad ; \quad B = \text{} \quad ; \quad C = \text{}$$

Step 6: $\frac{4x^2 - 7x + 3}{(2-x)(1+x^2)} \equiv \frac{A}{2-x} + \frac{Bx+C}{1+x^2} = \frac{1}{(2-x)} + \frac{-3x+1}{(1+x^2)}$

Step 7: Check solution

$$\begin{aligned} \frac{1}{2-x} + \frac{-3x+1}{1+x^2} &= \frac{1(\text{) + (-3x+1)(\text{)}}{(2-x)(1+x^2)} \\ &= \frac{\text{>}}{(2-x)(1+x^2)} \\ &= \frac{4x^2 - 7x + 3}{(2-x)(1+x^2)} \\ &= \frac{4x^2 - 7x + 3}{\text{>}} \\ &= \frac{4x^2 - 7x + 3}{-x^3 + 2x^2 - x + 2} \quad \checkmark \end{aligned}$$

Example 2.11: Complete the decomposition of $\frac{1}{x^3 - 2x^2 + x}$ into partial fractions

Solution:

Step 1: $Q(x) = x^3 - 2x^2 + x = x(\text{)}(\text{)}$

Note $(x - 1)$ is repeated and $(x - 1)$ is a factor

Step 2: $\frac{1}{x^3 - 2x^2 + x} = \frac{1}{x(x-1)^2} \equiv \frac{A}{x} + \frac{B}{(x-1)} + \frac{C}{\text{>}}$

Step 3: $\frac{1}{x(x-1)^2} \times x(x-1)^2 = \frac{A}{x} \times x(x-1)^2 + \frac{B}{(x-1)} \times x(x-1)^2 + \frac{C}{(x-1)^2} \times x(x-1)^2$

$$\begin{aligned} \therefore 1 &= A(x-1)^2 + Bx(x-1) + Cx \\ &= A(x^2 - 2x + 1) + Bx(x-1) + Cx \\ &= Ax^2 - 2Ax + A + Bx^2 - Bx + Cx \\ \therefore 1 &= (\quad) x^2 + (\quad) x + (A) \end{aligned}$$

Step 4: Coefficient of x^2 on LHS is 0; coefficient of x^2 on RHS is $(A + B)$

Coefficient of x^1 on LHS is \square ; coefficient of x^1 on RHS is \square

Coefficient of \square on LHS is \square ; coefficient of x^0 on RHS is (A)

Step 5: $\therefore 0 = A + B$

$$0 = -2A - B + C$$

$$1 = \square$$

Solving simultaneously (not shown here) yields

$$A = \square ; B = \square ; C = \square$$

Step 6: $\frac{1}{x^3 - 2x^2 + x} \equiv \frac{A}{x} + \frac{B}{x-1} + \frac{C}{(x-1)^2} = \frac{\square}{x} + \frac{-1}{\square} + \frac{\square}{(x-1)^2}$

Step 7: Check solution

$$\begin{aligned} &\frac{1}{x} + \frac{-1}{(x-1)} + \frac{1}{(x-1)^2} \\ &= \frac{\square}{x(x-1)^2} \\ &= \frac{x^3 - 2x^2 + 2x - x^2 + x - 1}{\square} \\ &= \frac{1}{x^3 - 2x^2 + x} \quad \checkmark \end{aligned}$$

Example 2.12: Complete the decomposition of $\frac{x^3 - 1}{x^4 + 8x^2 + 16}$ into partial fractions. The results for some steps are given but you have to do the working.

Solution:

Factorise the denominator

$$x^4 + 8x^2 + 16 = (x^2 + 4)^2 \quad \{\text{repeated irreducible quadratic}\}$$

$$\therefore \frac{x^3 - 1}{x^4 + 8x^2 + 16} = \frac{x^3 - 1}{(x^2 + 4)^2} \equiv \frac{Ax + B}{x^2 + 4} + \frac{\boxed{}}{(x^2 + 4)^2}$$

Determine values for A, B, C and D.

First clear fractions.

$$x^3 - 1 \equiv (Ax + B)(x^2 + 4) + (Cx + D)$$

Expand RHS and equate coefficients.

$$\begin{aligned} A &= 1 \\ B &= 0 \\ 4A + C &= 0 \\ 4B + D &= -1 \end{aligned}$$

Solve simultaneously for A, B, C, D

$$A = 1; \quad B = 0; \quad C = -4; \quad D = -1$$

$$\therefore \frac{x^3 - 1}{x^4 + 8x^2 + 16} = \frac{1}{x^2 + 4} + \frac{-4x - 1}{(x^2 + 4)^2}$$

Check solution.

If you had difficulty with solving the little equations to obtain A, B, C etc. work through this next section otherwise if you now feel comfortable with the method for partial fractions try the following exercises.

Solving several simultaneous equations involving more than two variables involves reducing the equations by various substitutions until two equations in the same two unknowns are obtained.

e.g. from Example 2.11

$$4 = A - B \quad \text{_____} \quad \textcircled{1}$$

$$-7 = 2B - C \quad \text{_____} \quad \textcircled{2}$$

$$3 = A + 2C \quad \text{_____} \quad \textcircled{3}$$

From ①, $A = 4 + B$

\therefore Substituting in ③ for A yields

$$3 = 4 + B + 2C$$

$$\therefore -1 = B + 2C \quad \text{_____} \quad \textcircled{4}$$

Now ② and ④ are two equations in the same two unknowns.

From ②, $C = 2B + 7$

\therefore Substituting in ④ for C yields

$$-1 = B + 2 \times (2B + 7)$$

$$\therefore -15 = 5B \quad \therefore B = -3$$

Substituting in $C = 2B + 7$ for B yields

$$C = 2 \times (-3) + 7 \quad \therefore C = 1$$

Substituting in $A = 4 + B$ for B yields

$$A = 4 + (-3) \quad \therefore A = 1$$

Exercise Set 2.14

Express each of the following as partial fractions

- Take care that the numerator and denominator are both polynomials before attempting the decomposition.
- Also ensure that the numerator does not have a higher degree than the denominator. (If this is the case you will need to use long division to get the remainder as a proper rational function which you can then decompose into partial fractions.)
- Make sure you check your answers.

1. $\frac{3-x}{(2-x)(2x-1)}$

2. $\frac{9x-72}{x^3-3x^2-18x}$

3. $\frac{x^2-3x+12}{(2-x)(1+x^2)}$

4. $\frac{x^3+2x^2-x+3}{x^2-x-6}$

5. $\frac{9x}{(1+x)(1-2x)^2}$

6. (a) $\frac{1}{r(r+1)}$

(b) Using the result from 6(a) find $S_n = \sum_{r=1}^n \frac{1}{r(r+1)}$ and deduce the value of S_∞ .

Other Important Non Linear Functions

In the last section of work you drew some graphs of rational functions. These make up one group of non linear functions that you need to be familiar with. (I'm assuming now you can draw polynomials easily.) In previous mathematics units you will have met many other non linear functions so here we will only briefly review the more important ones.

$$y = \frac{1}{x} ; y = \sqrt{x} ; y = |x| ; y = e^x ; y = e^{-x} ; y = \log_e x ; \text{circles; and hyperbolas}$$

1. $y = \frac{1}{x}$

This function is undefined at $x = 0$. i.e. the graph will have an asymptote at $x = 0$, i.e. the y axis is the asymptote. Complete the table and roughly sketch the graph of $\frac{1}{x}$ below.

x	-100	-10	-2	-1	0	1	2	5	10
$y = \frac{1}{x}$					undef.				

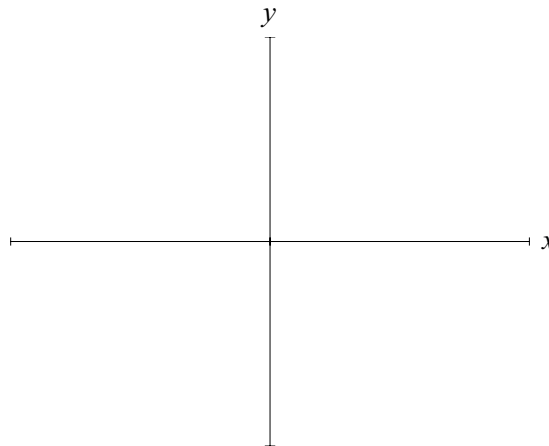

You should get a graph like this. (Note that this is a special case of a hyperbola.)

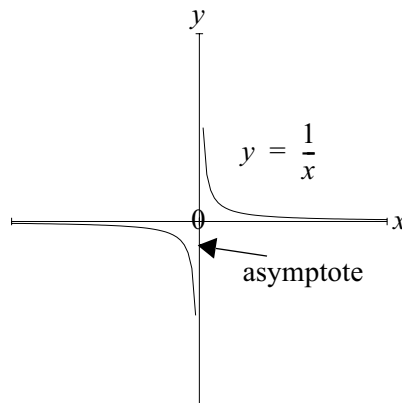

2. $y = \sqrt{x}$

This function is not defined for negative values of x . Complete the table and roughly sketch the graph of \sqrt{x} below.

x	100	64	49	36	25	9	5	4	3	2	1	0	0.1
$y = \sqrt{x}$													

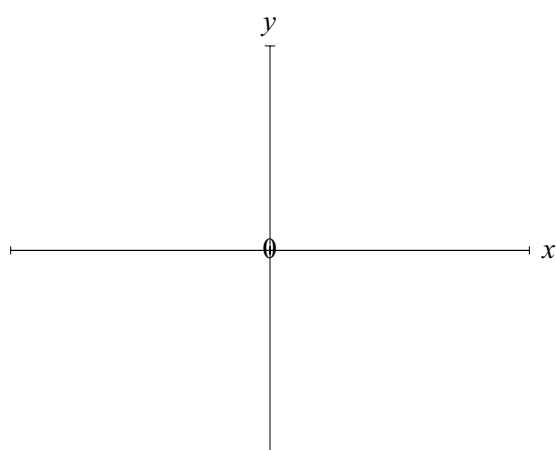

You should get a graph like this:

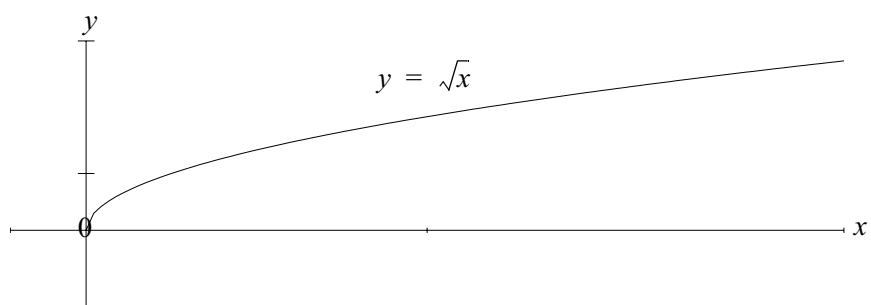

Note: The graph of $y = -\sqrt{x}$ is:

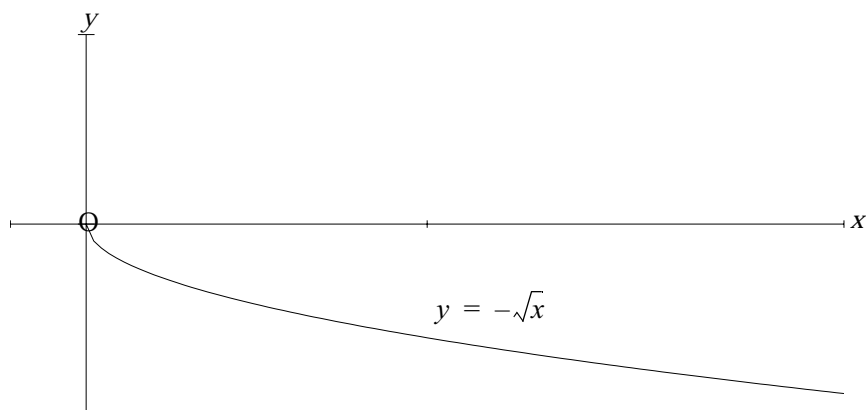

3. $y = |x|$

This function is defined for all values of x . The output of the function is always positive because the symbol ‘| |’ means ‘absolute value’. Complete the table and roughly sketch the graph of $|x|$ below.

x	-100	-50	-10	-5	-2	-1	0	1	2	5	10	50	100
$y = x $													

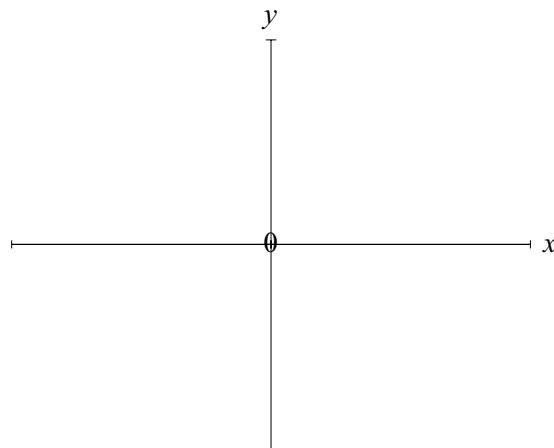

You should get a graph like this:

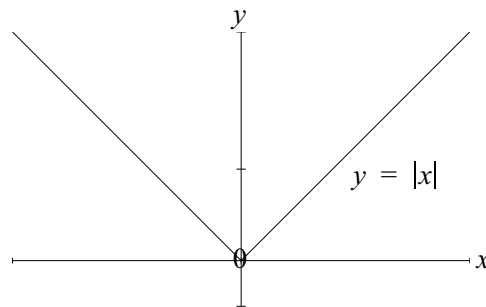

4. $y = e^x$

This is **THE** positive exponential function. i.e. the positive exponential function with base e . Complete the table and roughly sketch the graph of e^x below. See Note 1

x	-100	-50	-10	-5	-2	-1	0	1	2	5	10	50	100
$y = e^x$													

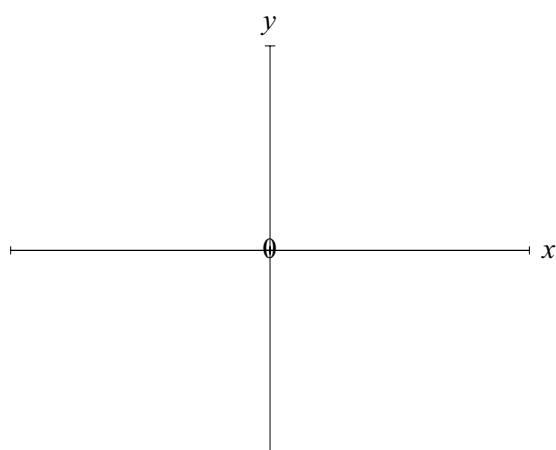

You should get a graph like this:

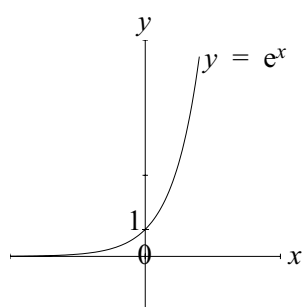

Notes

- Exponential functions can have any base. The most common are e and 10 .

5. $y = e^{-x}$

This is **THE** negative exponential function. Complete the table and roughly sketch the graph of e^{-x} below.

x	-100	-50	-10	-5	-2	-1	0	1	2	5	10	50	100
$y = e^{-x}$													

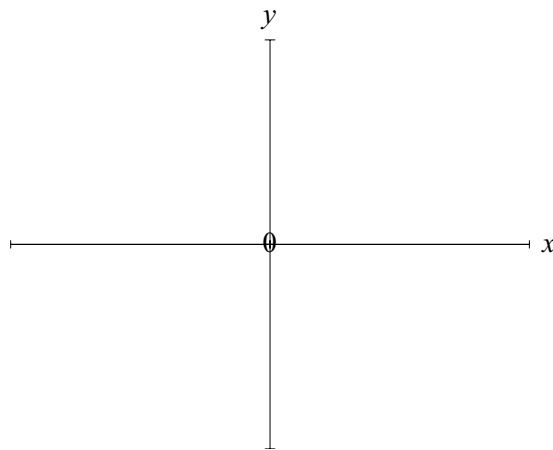

You should get a graph like this:

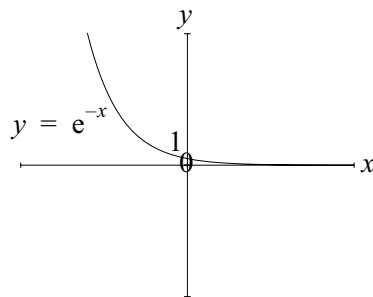

6. $y = \log_e x$ or $\ln x$

This is the logarithmic function with base e . As for exponentials, logarithmic functions can have any base. The most common are e and 10. Use your calculator and roughly sketch the graph of $y = \ln x$ below.

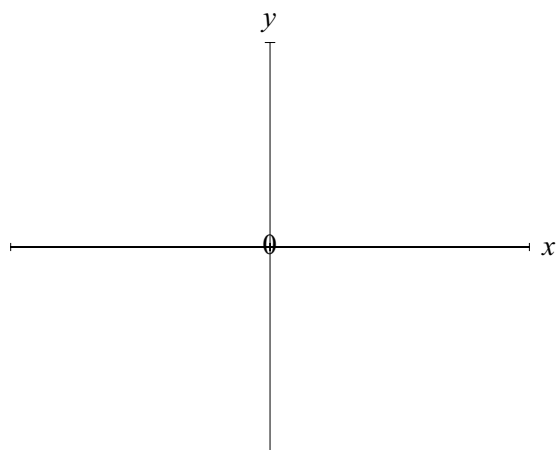

You should get a graph like this:

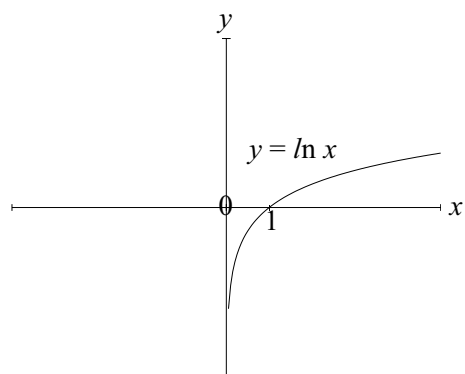

Note: Do not confuse the graph of $\ln x$ and the graph of \sqrt{x} .

7. **Circles** e.g. $(x + 1)^2 + (y - 2)^2 = 4$

i.e. $(x + 1)^2 + (y - 2)^2 = 2^2$

This circle is centred at $(-1, 2)$ and has radius 2.

Note: The General Form of a circle is $(x - h)^2 + (y - k)^2 = r^2$ where (h, k) is the centre and r the radius.

The graph of $(x + 1)^2 + (y - 2)^2 = 4$ is:

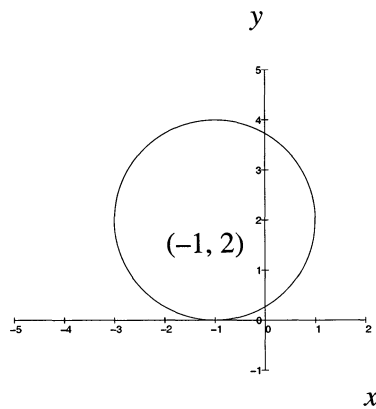

8. **Hyperbolas** e.g. $y = \frac{1}{x - 2} - 3$

This hyperbola has vertical asymptote at $x = 2$;

See Note 1

has horizontal asymptote at $y = -3$;

See Note 2

cuts x -axis at $(\frac{7}{3}, 0)$; and cuts y -axis at $(0, \frac{-7}{2})$

Note: The General Form of an hyperbola is $y = \frac{c}{x - a} + b$,

where the vertical asymptote is at $x = a$;

horizontal asymptote is at $y = b$;

curve cuts x -axis at $(a - \frac{c}{b}, 0)$;

Notes

1. When $x \rightarrow 2$, y tends to $+\infty$ or $-\infty$ depending on whether x approaches 2 from the positive or negative side. Under such conditions we say the function has a vertical asymptote at $x = 2$.
2. As $x \rightarrow +\infty$ or $-\infty$, y tends to -3 , thus the function has a horizontal asymptote at $y = -3$.

curve cuts y -axis at $\left(0, b - \frac{c}{a}\right)$

This is the form of the hyperbola that we will use in this unit. In your previous studies (e.g. in unit 11083) you may have met an alternative form of the hyperbola based on a geometric construction of this type of function when it is centred at the origin. e.g. $\frac{x^2}{a^2} - \frac{y^2}{b^2} = 1$ where $b^2 = c^2 - a^2$ and the hyperbola has foci at $(-c, 0)$ and $(c, 0)$.

Complete the table and draw the graph of $y = \frac{1}{x-2} - 3$ below.

x	-2	-1	0	1	2	3
$y = \frac{1}{x-2} - 3$						

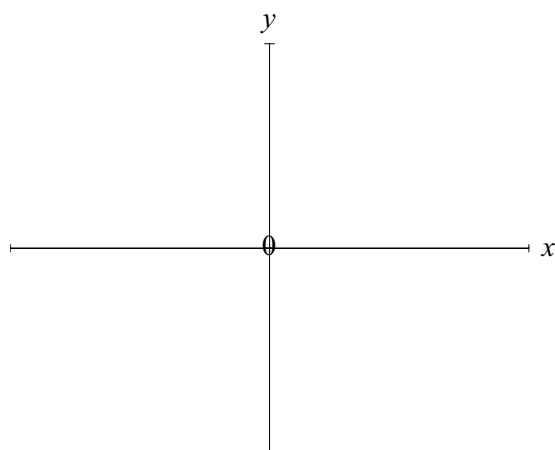

You should get this graph:

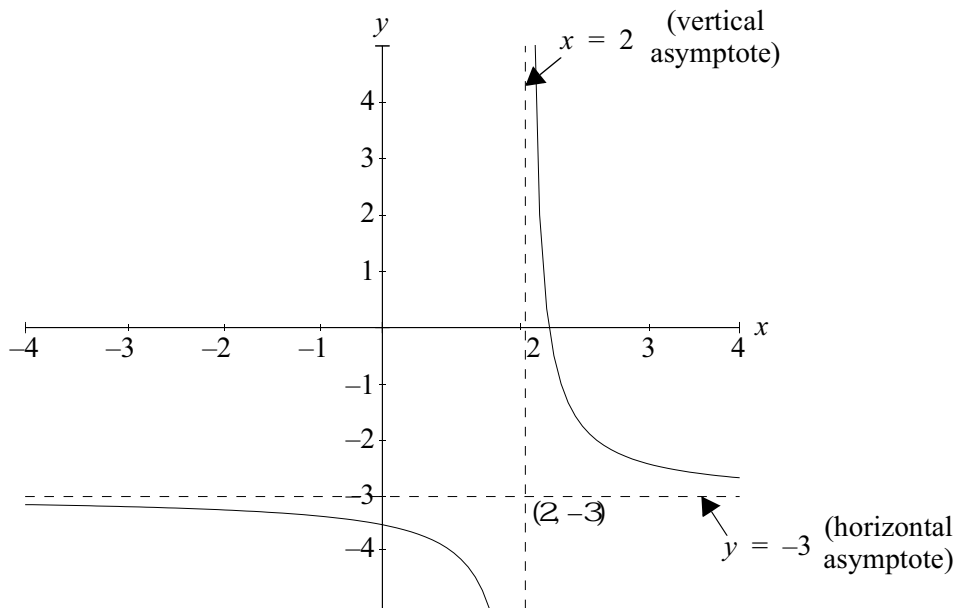

Note: Every hyperbola has two branches which are mirror reflections. In this example the reflections are across the line which passes through $(2, -3)$ at an angle of 135° or 45° (provided same scale is used on each axis)

Before proceeding with the next section of work pause here and check that you can draw graphs of straight lines, parabolas, cubics and the most common non linear functions. If you need to revise, do so now, as success with the next section depends on your familiarity with such graphs.

Solving Simultaneous Equations Algebraically and Graphically

Solving simple simultaneous algebraic equations is easy if the equations are linear.

Example 2.13: Solve $y = 2x + 7$
 $y = -2x + 5$

Solution:

This set of equations can be solved algebraically by

- (i) equating the two Right Hand Sides; solving for x ; substituting to get y , or
- (ii) by adding the two equations (thus eliminating x) and solving for y ; substituting to get x .

Method (i)	Method (ii)
$2x + 7 = -2x + 5$	$2y = 12$
$4x = -2$	$y = 6$
$x = -\frac{1}{2}$	$y = 2x + 7$
$y = 2x + 7$	$6 = 2x + 7$
$= 2 \times -\frac{1}{2} + 7$	$\therefore x = -\frac{1}{2} \rightarrow \text{Point } (-\frac{1}{2}, 6)$
$= 6 \rightarrow \text{Point } (-\frac{1}{2}, 6)$	

$\therefore (-\frac{1}{2}, 6)$ satisfies both equations and hence is the required solution.

The set of equations can also be solved graphically. Solving these equations graphically means we are looking for points where the graphs of the equations intersect.

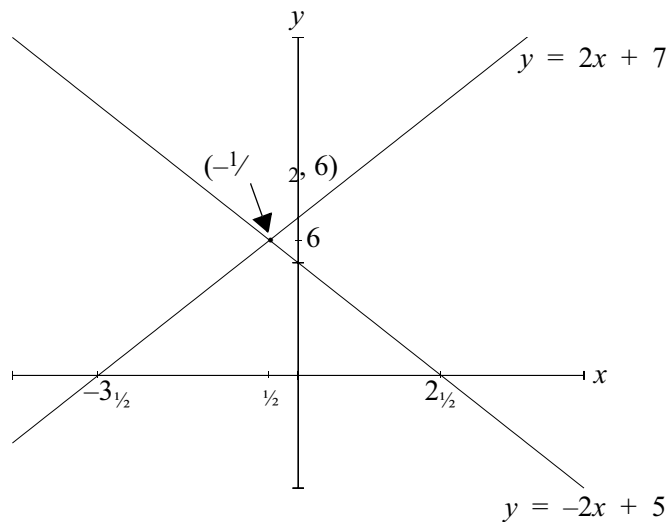

Example 2.14: Solve $y = 3x + 2$ ①
 $x^2 + y^2 = 4$ ②

Solution:

Algebraically:

From ①, $y = 3x + 2$ \therefore substitute in ② for y

$$\begin{aligned} x^2 + (3x + 2)^2 &= 4 \\ x^2 + 9x^2 + 12x + 4 &= 4 \\ \therefore 10x^2 + 12x &= 0 \\ \therefore x(10x + 12) &= 0 \\ \therefore x = 0 \text{ or } x &= -\frac{6}{5} \end{aligned}$$

From ①, when $x = 0$, $y = 3 \times 0 + 2 = 2 \rightarrow (0, 2)$ as one solution

From ①, when $x = -\frac{6}{5}$, $y = 3 \times -\frac{6}{5} + 2 = -\frac{8}{5} \rightarrow (-\frac{6}{5}, -\frac{8}{5})$ as the other solution

There are two solutions: when $x = 0, y = 2$ and Check solutions by
when $x = -\frac{6}{5}, y = -\frac{8}{5}$ substituting in both
original equations

Graphically:

To solve these equations graphically, examine the equations and determine the types of graphs involved.

$y = 3x + 2$ is a straight line with slope 3 and y -intercept of 2 ; and $x^2 + y^2 = 4$ is a circle with centre at (0, 0) and radius 2.

Drawing the graphs of these equations gives:

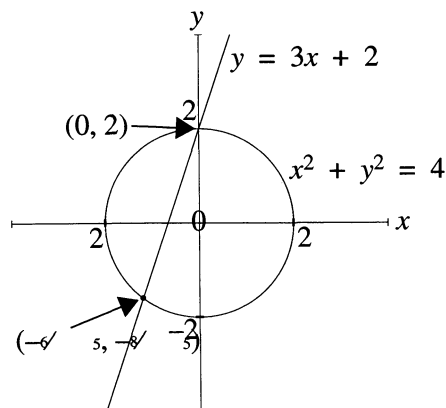

and zooming in on the points of intersection yields the required solutions of (0, 2) and $(-\frac{6}{5}, -\frac{8}{5})$

Whenever possible we solve equations algebraically as then the solution is exact. If we cannot do this (or it is computationally difficult) graphical techniques are often used.

Example 2.15: Solve $x^2 - 3 - \sqrt{x} = 0$.

Solution:

We can write this equation as $x^2 - 3 = \sqrt{x}$.

If we let $y_1 = x^2 - 3$ and $y_2 = \sqrt{x}$, then, when $y_1 = y_2$ (i.e. $x^2 - 3 = \sqrt{x}$) we have the solution of the original equation.

To solve this set of equations is quite messy but it is easy to do graphically.

$y_1 = x^2 - 3$ is a parabola, saucer shaped (i.e. with a minimum) which cuts the y -axis at $y = 3$. Its axis of symmetry is $x = \frac{3}{2}$. Following the work in the Revision Module or using calculus (if you have studied course TPP7183 / 11083 or its equivalent) you can draw $y_1 = x^2 - 3$.

$y_2 = \sqrt{x}$ is a non linear equation whose graph we also know and can therefore draw.

We are interested only in those parts of the graphs where the curves intersect. A rough sketch shows that the curves intersect once only, at about (2.1, 1.5). To obtain a better estimate you can redraw the curves for the domain say from $x = 1$ to $x = 3$ or zoom in on the point of intersection using your computer package.

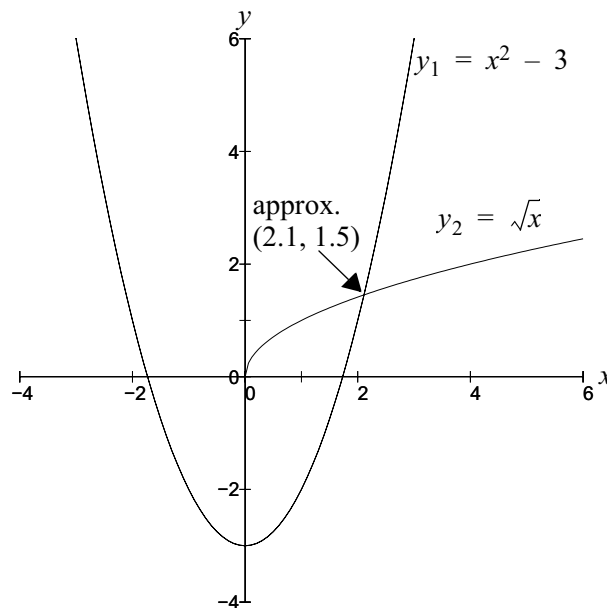

Now you can use the graphical technique to solve simultaneous equations you have a tool for finding roots of and solving quite complicated equations. Here's one more example before you try the exercise set.

Example 2.16: Find the **positive** solution of $x + 3 = e^{0.5x}$

Solution:

The solutions of $x + 3 = e^{0.5x}$ are the same values of x which satisfy the simultaneous equations,

$$\begin{aligned} y_1 &= x + 3 \\ y_2 &= e^{0.5x} \end{aligned}$$

Using the graphical approach seems sensible.

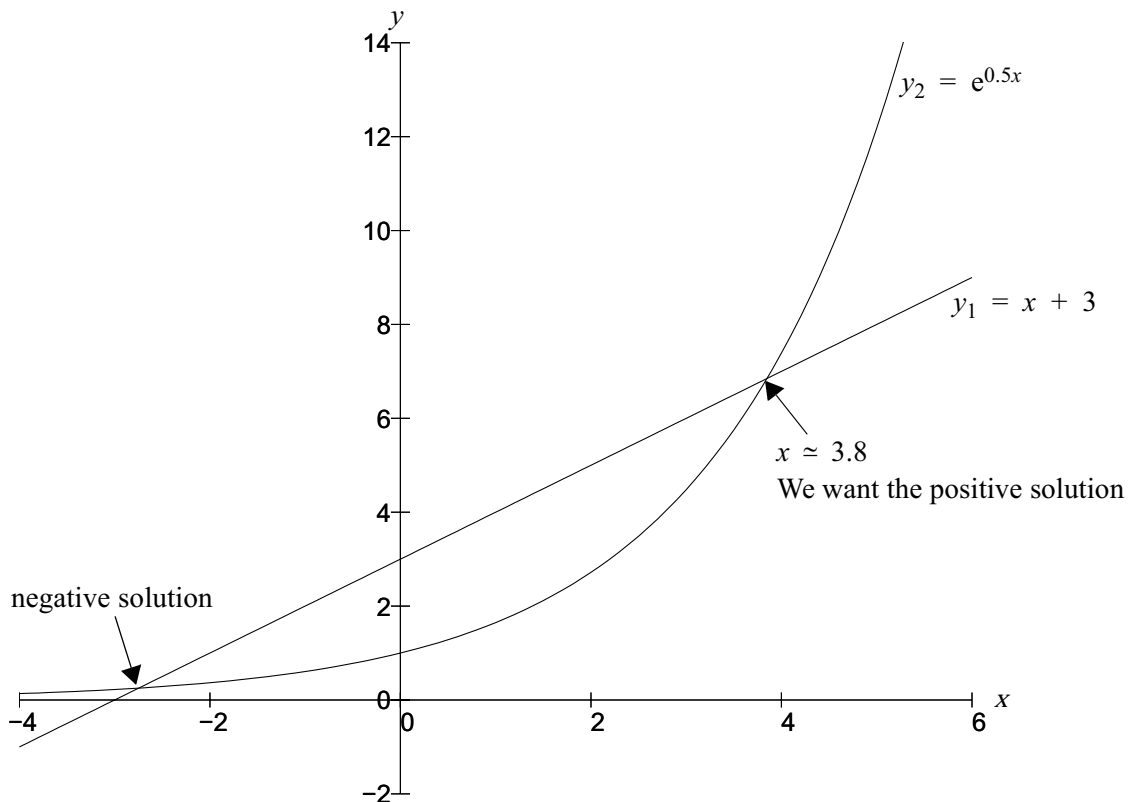

So the positive solution is $x \approx 3.8$. We can check the validity of this solution by substituting in the original equation.

$$x + 3 = e^{0.5x}$$

Consider LHS: when $x = 3.8$

$$x + 3 = 3.8 + 3 = 6.8$$

Consider RHS: when $x = 3.8$

$$e^{0.5x} = e^{0.5 \times 3.8} = e^{1.9} = 6.69 \approx 6.8$$

So $x = 3.8$ is a reasonable approximation to the solution.

Using your computer package you could zoom in on the point of interest and obtain a more accurate approximation.

Exercise Set 2.15

For Questions 1–8 find the solution of each of set of simultaneous equations. Use your graphing package where appropriate.

1. $y = 2x + 4$
 $y = 8x - 2$

2. $y = 2x - 4$
 $y = 2x + 6$

3. $(x - 2)^2 + (y - 4)^2 = 16$
 $x = 3$

4. $x^2 + y^2 = 1$
 $(x - 3)^2 + y^2 = 4$

5. $x^2 + y^2 - 4x + 2y + 4 = 0$
 $y = -3x$

[Hint: Complete the square for x and for y to obtain the standard form of a circle for the first equation.]

6. The equation of the circle passing through $(0, 0)$, $(0, 3)$ and $(1, 0)$
 $y = \ln x$

[Hint: Write three equations to the circle using each of the coordinates given and then solve to get h , k and r]

7. $y = e^{-x}$
 $y = \frac{3}{1-x} + 2$ for $x < 1$

[Hint: Multiply numerator and denominator of $\frac{3}{1-x}$ by -1 to get the second equation in standard form of a hyperbola.]

8. $y = |2x|$
 $y = \frac{2}{x}$

9. Obtain an approximate value for the positive solution of the equation

$$(x + 1)(2 - x) = 5 \ln(1 + x)$$

[Hint: Find the solution of $y_1 = (x + 1)(2 - x)$
 $y_2 = 5 \ln(1 + x)$]

Inverse Functions

In the Revision Module we said that a function defines the relationship between two sets.

e.g. the function $b = b(a) = 3a$ says that b depends on the chosen value of a , and the value of b is given by three times the value of a .

Some ordered pairs given by this function are $(2, 6), (4, 12), (8, 24), (100, 300), (-14, -42), (0.2, 0.6), (-\frac{1}{8}, -\frac{3}{8})$ etc.

We also said that

- if an element in the domain x , maps to more than one element in the range y , then the relationship between x and y is **not** a function e.g. $y = \pm\sqrt{x}$ and $x^2 + y^2 = 1$ are **not** functions Graphically this means that at least one vertical line intersects the graph of the set of ordered pairs (x, y) at more than one point.
- a one-to-one function occurs when each element in the domain is paired with only one unique element in the range. $y = 3x$ and $y = \sqrt{x}$ are both one-to-one functions Graphically this means that horizontal lines will intersect with the graph of the function once only.
- a many-to-one function is one where different elements in the domain yield the same element in the range e.g. $y = x^2$ is a many-to-one function because, for example, when $x = 2$ and when $x = -2$, the corresponding y values are both 4. Graphically this means that at least one horizontal line will intersect with the graph of the function in more than one place.

In this section we will examine how to find the inverse functional relationship i.e. the relationship which maps **from the range to the domain**, given that we know the relationship that maps **from the domain to the range**.

A function will have an inverse if each element of the domain is related to a unique element in the range i.e. if there is a one-to-one mapping from Set X to Set Y .

We will use the one-to-one function $y = f(x) = 3x$ for $-2 \leq x \leq 2$ to demonstrate.

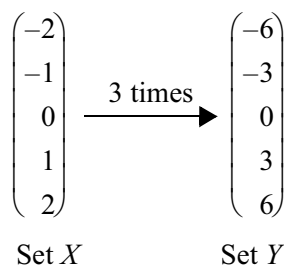

See Note 1

Notes

1. Only the integer values are shown but all the real numbers between -2 and 2 are in the Set X and hence all the real numbers between -6 and 6 are in the Set Y .

If f is a one-to-one function and $y = f(x)$, the inverse of f , denoted by f^{-1} , is a unique function such that $f^{-1}(f(x)) = x$. See Note 1

So the inverse function has a domain which is the same as the range of the original function and a range which is the same as the domain of the original function.

For our example,

$$f(x) = 3x$$

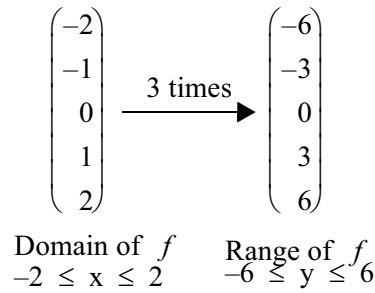

So $f^{-1}(x)$ has domain of $-6 \leq x \leq 6$ and range of $-2 \leq y \leq 2$.

What do you think is the functional relationship for f^{-1} ? [**Hint:** Examine the ordered pairs (x, y) with the order reversed.]

★

Answer:

You should have found that $f^{-1}(x) = \frac{1}{3}x$.

The graphs of $f(x)$ and $f^{-1}(x)$ are shown here on the same set of axes.

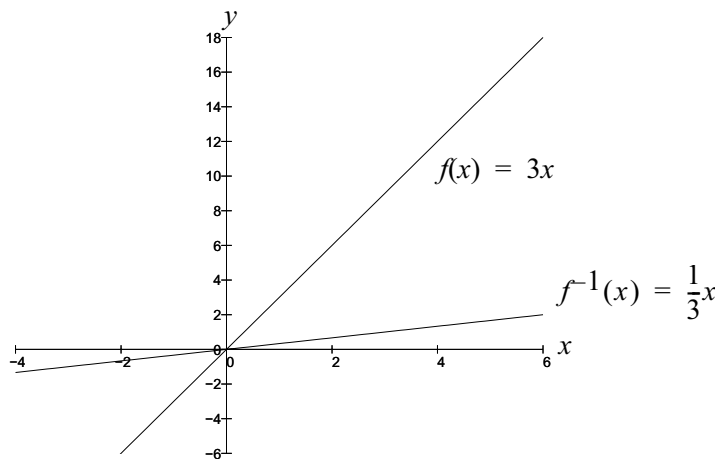

Notes

- $f^{-1}(f(x))$ is a composite function. In composite functions the output from the inner function becomes the input for the outer function, e.g. if $y = 2x$ and $w = x^2 + 1$, $(y(w(x)))$ is a composite function where the output from $w(x)$ is the input for y , e.g. if $x = 3$, $y(w(x)) = 2(3^2 + 1) = 2 \times 10 = 20$.

Now you can check that $f^{-1}(f(x)) = x$. Take any value for x , say $x = 1.5$, and read off the corresponding $f(x)$ value. When $x = 1.5$, $f(x) = f(1.5) = 4.5$.

Now use that value of $f(x)$ as the input value for $f^{-1}(x)$.

When $x = 4.5$, $f^{-1}(x) = f^{-1}(4.5) = 1.5$, which was the original value chosen for x .

- ★ Try to show that $f(f^{-1}(x)) = x$ also, by choosing a value of x , say $x = 6$, as the input for $f^{-1}(x)$ first.

.....

Answer:

From the graph when $x = 6$, reading from $f^{-1}(x)$ we get, $f^{-1}(6) = 2$. Then when $x = 2$, reading from $f(x)$ we get $f(2) = 6$

- ★ Redraw the graphs of $f(x) = 3x$ and $f^{-1}(x)$ on the same axes with the **same scale** on each axis. Then draw a line at 45° to the x -axis on the axes (i.e. draw $y = x$). Can you see that $f(x)$ and $f^{-1}(x)$ are mirror images of each other across this line? (i.e. f and f^{-1} are symmetric about the line $y = x$)

Here’s another graphical example of a function and its inverse. (Drawing lines perpendicular to $y = x$ and measuring each side of this line assists in getting the correct graph for the inverse.)

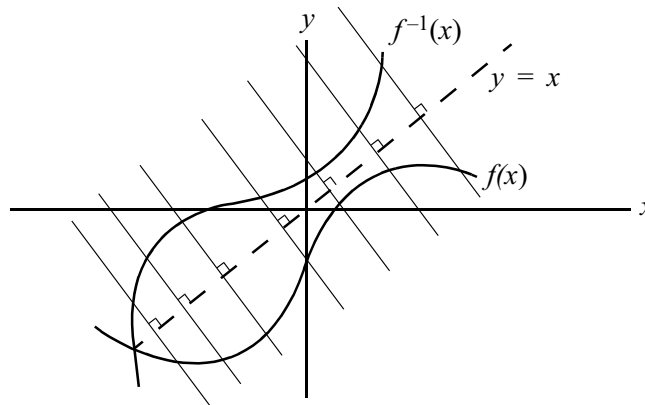

Exercise Set 2.16

1. Examine the graphs below and determine which graphs represent functions.

Of the graphs that represent functions which are one-to-one?

Of the functions that are one-to-one which pairs of graphs represent functions and their inverses?

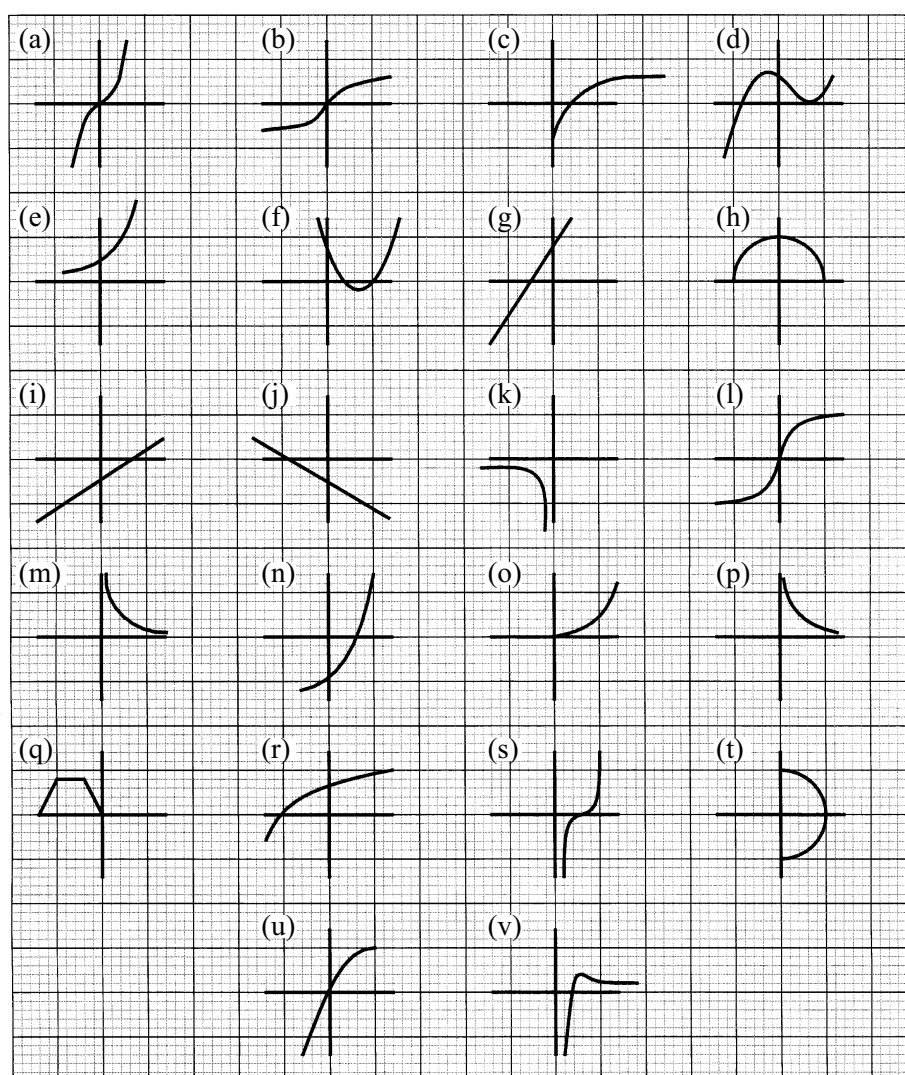

2. If $f(x) = 3x + 2$ and $f^{-1}(x) = \frac{1}{3}(x - 2)$

(i) sketch $f(x)$ and $f^{-1}(x)$ on the same axes with the same scales on each axis.

(ii) choose two values of x and show graphically that $f(f^{-1}(x)) = x$

(iii) choose two other values of x and show graphically that $f^{-1}(f(x)) = x$.

We need to be able to find the formula for inverse functions **algebraically**. We have a clue for the method from the graphical work just completed.

Example 2.17:

Find the inverse of $f(x) = 5x + 3$, if it exists.

Solution: First check by asking

- Is $f(x)$ a one-to-one function? ‘Yes, it is a one-to-one function as it is a straight line and any horizontal line will intersect with it once only.’
- Is the domain of $f(x)$ restricted? ‘No, $f(x)$ is defined for all values of x as there are no restrictions given.’

$$\begin{aligned} f(x) &= 5x + 3 \\ \text{i.e. } y &= 5x + 3 \end{aligned}$$

Now in $f^{-1}(x)$ the variables x and y have opposite to roles to those in $f(x)$.

[**Recall** the change in order of the ordered pairs of the mappings of Set X and Set Y .]

So we interchange the variables x and y to get

$$x = 5y + 3$$

and solve for y which will now be given by f^{-1}

$$\begin{aligned} \text{If } x &= 5y + 3 \\ 5y &= x - 3 \\ \therefore y &= \frac{1}{5}(x - 3) \end{aligned}$$

$$\text{i.e. } f^{-1}(x) = \frac{1}{5}(x - 3)$$

As we usually do, we now try to validate our answer. If we can show that $f^{-1}(f(x)) = x$ or $f(f^{-1}(x)) = x$, then our inverse must be correct.

$$f(f^{-1}(x)) = f\left(\underbrace{\frac{1}{5}(x-3)}_{\substack{\text{output from } f^{-1} \\ \text{which becomes} \\ \text{input for } f}}\right) = 5\left(\underbrace{\frac{1}{5}(x-3)}_{\text{input for } f}\right) + 3 = x - 3 + 3 = x \quad \checkmark$$

Exercise 2.18:

Find the inverse of $y = x^2 - 2$, if it exists.

Solution: First check

- Is $f(x)$ a one-to-one function? ‘No, $f(x) = x^2 - 2$ is a parabola and thus at least one horizontal line will cut its graph in more than one place. This means f is not a one-to-one function \therefore its inverse does not exist.’

Example 2.19:

Find the inverse of $y = x^2 + x - 6$, where $x > -\frac{1}{2}$, if it exists.

Solution: First check

- Is $f(x)$ a one-to-one function? ‘No it is not as it is a parabola, **but** the domain is restricted to $x > -\frac{1}{2}$ \therefore need to check if for this restricted domain f is one-to-one.’

The easiest way to do this is to sketch the graph of $y = x^2 + x - 6$

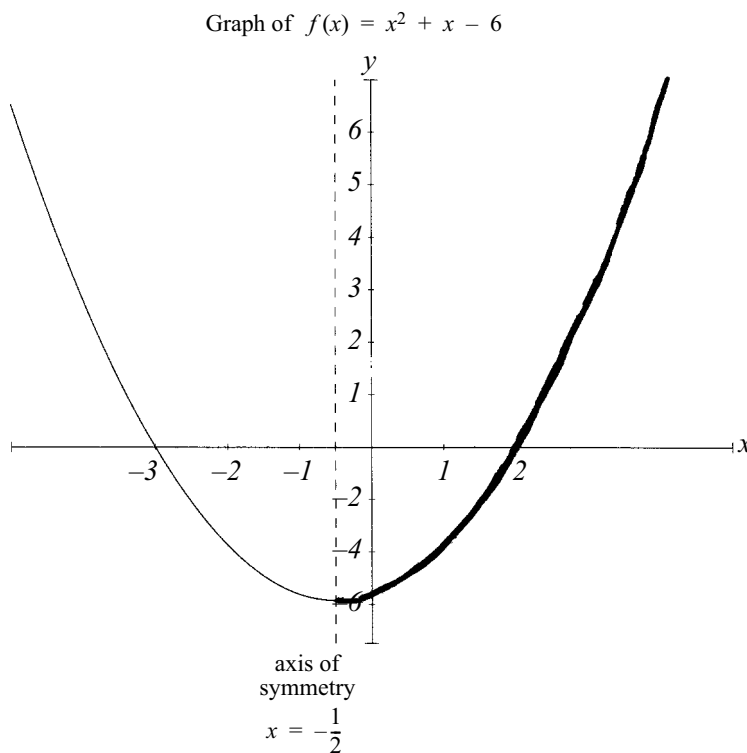

The part of the graph we are interested in (i.e. for $x > -\frac{1}{2}$) is shown by the heavier line and we note that for this restricted domain f is indeed one-to-one.

Domain of f is $-\frac{1}{2} < x < \infty$

and Range of f is $-6\frac{1}{4} < y < \infty$

\therefore Domain of f^{-1} is $-6\frac{1}{4} < x < \infty$

and Range of f^{-1} is $-\frac{1}{2} < y < \infty$

Now we will find $f^{-1}(x)$ algebraically.

If $f(x) = x^2 + x - 6$ for $-\frac{1}{2} < x < \infty$

i.e. $y = x^2 + x - 6$ for $-\frac{1}{2} < x < \infty$

Let $x = y^2 + y - 6$

$\therefore y^2 + y = 6 + x$

$\therefore (y + \frac{1}{2})^2 - \frac{1}{4} = 6 + x$ {Completing the square for y on LHS.}

$\therefore (y + \frac{1}{2})^2 = x + 6\frac{1}{4}$

$y + \frac{1}{2} = +\sqrt{x + 6\frac{1}{4}}$

$\therefore y = \sqrt{x + 6\frac{1}{4}} - \frac{1}{2}$

i.e. $f^{-1}(x) = \sqrt{x + 6\frac{1}{4}} - \frac{1}{2}$

Check solution

$$\begin{aligned}
 f^{-1}(f(x)) &= f^{-1}(x^2 + x - 6) \\
 &\quad \text{output from } f \text{ to be used as input for } f^{-1} \\
 &= \sqrt{(x^2 + x - 6) + 6\frac{1}{4}} - \frac{1}{2} \\
 &= \sqrt{x^2 + x + \frac{1}{4}} - \frac{1}{2} \\
 &= \sqrt{\left(x + \frac{1}{2}\right)^2} - \frac{1}{2} \quad \text{{Positive root only because of restricted domain}} \\
 &= x + \frac{1}{2} - \frac{1}{2} \\
 &= x \quad \checkmark
 \end{aligned}$$



We will meet inverse trigonometric functions in a later module. Other important functions that you need to be able to find and use inverses for are the **exponential and logarithmic functions**.

If $f(x) = a^x$, $f^{-1}(x) = \log_a x$.
 So $f(f^{-1}(x)) = a^{\log_a x} = x$ and $f^{-1}(f(x)) = \log_a a^x = x$
 e.g. If $f(x) = e^x$, $f^{-1}(x) = \log_e x$ or $\ln x$
 e.g. If $f(x) = \log_2 x$, $f^{-1}(x) = 2^x$

Exercise Set 2.17

- If $f(x)$ equals the height in centimetres of a person who weighs x kilograms what is the meaning of $f^{-1}(100)$ in practical terms?
- Decide if the function f will have an inverse for each of the following scenarios
 - $f(d)$ is the number of litres of petrol in your car tank when the odometer reads d km.
 - $f(t)$ is the number of customers in your local store at t minutes past noon on January 8, 1996.
 - $f(x)$ is the volume in litres of x kilograms of ice at 4°C .
 - $f(n)$ is the number of first year students whose birthday is on the n th day of the year.
 - $f(w)$ is the cost in cents of mailing a letter that weighs w grams.

- Consider the table of values below

x	1	2	3	4	5	6	7
$f(x)$	3	-7	19	4	178	2	1

- will $f(x)$ have an inverse? Explain your answer.
 - if the domain of $f(x)$ is the integers from 1 to 7, what is the domain and range of $f^{-1}(x)$?
- Consider the function $f(x) = x^2 + 3x$
 - why does this function not have an inverse?
 - choose a domain for $f(x)$ so that the inverse can be found.
 - sketch $f(x)$ for this restricted domain and $f^{-1}(x)$ on the same axes.

- The cost, C of producing P articles is given by the function

$$C(P) = 100 + 2P$$

- should the domain of $C(P)$ be restricted? If so, how?
 - find the formula for the inverse function.
 - explain in practical terms what the inverse function tells you.
- Find the inverse function for each of the following. Prove your solutions are correct.
 - $f(x) = 2 + 3x$
 - $f(x) = 1 - x^2$ for $x \geq 0$
 - $f(x) = 50e^{0.1x}$
 - $f(x) = 2x^3 - 4$
 - $f(x) = 2^{x^2-1}$ for $x \geq 0$
-

Continuity

You’ve probably come across this definition of continuity. ‘A function is continuous if it is possible to draw its graph without lifting the pen from the paper’. This is a common statement used to describe continuity but at this level of mathematics we need a more rigorous mathematical definition.

You have already met many continuous functions e.g. all the polynomials and exponential functions and several discontinuous functions e.g. the hyperbolas.

Let’s re-examine the hyperbola $y = \frac{1}{x-2} - 3$ which you drew on page 2.55 and discuss continuity in a more mathematical sense using **limits**. Limits and continuity are important concepts for bridging from algebra and geometry to calculus.

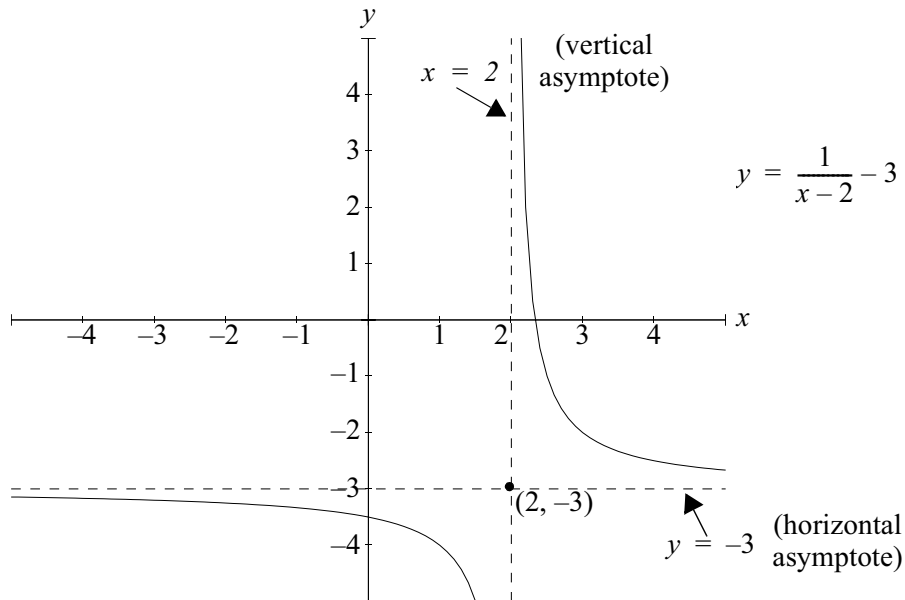

From the graph above,

As x gets bigger and bigger i.e. as x approaches $+\infty$, the value of y gets closer and closer to -3 . (The horizontal asymptote is $y = -3$). We say the limit of $f(x) = \frac{1}{x-2} - 3$ as x approaches $+\infty$ is -3 .

A shorthand way to write this is: $\lim_{x \rightarrow +\infty} f(x) = \lim_{x \rightarrow +\infty} \frac{1}{x-2} - 3 = -3$

As x gets smaller and smaller i.e. as x approaches $-\infty$, the value of y again gets closer and closer to -3 .

$$\text{i.e. } \lim_{x \rightarrow -\infty} f(x) = \lim_{x \rightarrow -\infty} \frac{1}{x-2} - 3 = -3$$

Now obviously something of interest is also happening at $x = 2$. (The vertical asymptote is $x = 2$). As x approaches 2 from the right (i.e. the positive side), the y values get bigger and bigger.

$$\text{i.e. } \lim_{x \rightarrow 2^+} f(x) = \lim_{x \rightarrow 2^+} \frac{1}{x-2} - 3 = +\infty \quad \text{See Note 1}$$

As x approaches 2 from the left (i.e. the negative side) the y values get smaller and smaller.

$$\text{i.e. } \lim_{x \rightarrow 2^-} f(x) = \lim_{x \rightarrow 2^-} \frac{1}{x-2} - 3 = -\infty \quad \text{See Note 2}$$

So the limits of $f(x)$ as x approaches 2 from the positive side and the negative side are not equal to a single number. Thus we say that $f(x) = \frac{1}{x-2} - 3$ does not have a limit as x approaches 2. See Note 3

If a function does not have a limit at some point, say $x = a$ then the function is not continuous at $x = a$. (We will come to some further conditions for continuity shortly.)

Whenever a function is undefined at some point (e.g. the value of x giving the vertical asymptote of our hyperbola), it is discontinuous at that point.

Example 2.20:

Examine the graph of the function below and discuss its continuity.

$$f(x) = \begin{cases} x^2 + 1 & \text{for } x > 2 \\ 4 & \text{for } x = 2 \\ 2x + 1 & \text{for } x < 2 \end{cases} \quad \text{See Note 4}$$

Solution:

x	-3	-2	-1	0	1	2	3	4
$f(x)$	-5	-3	-1	1	3	4	10	17

Notes

1. The positive sign 2^+ used as a superscript means ‘approaching 2 from the positive side’.
2. The negative sign 2^- used as a superscript means ‘approaching 2 from the negative side’.
3. ∞ and $-\infty$ are not numbers.
4. This functions is defined differently for different parts of the domain.

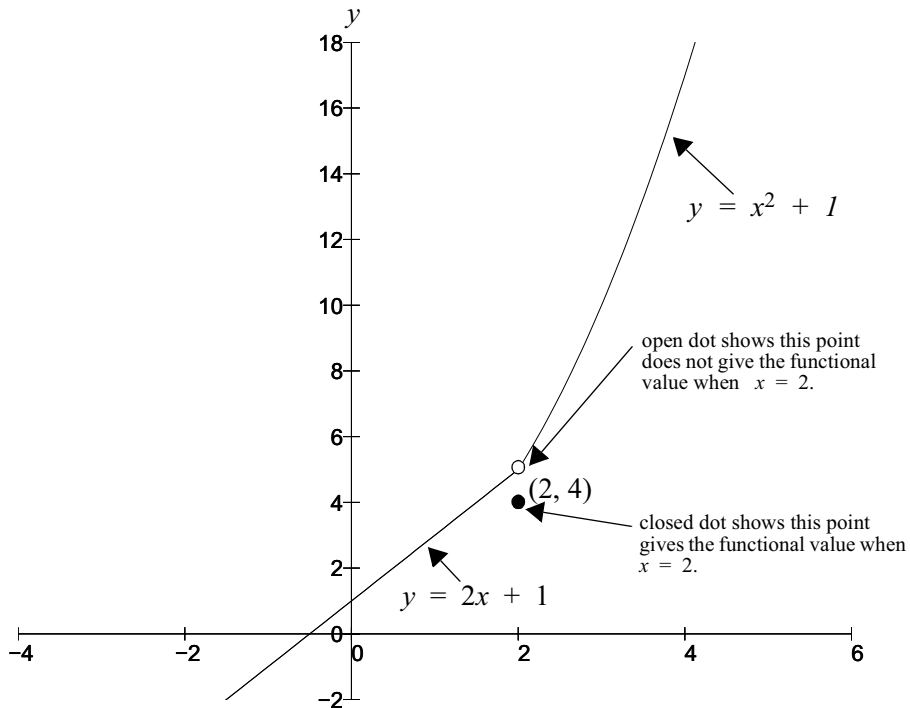

Something interesting is happening near $x = 2$. Let's investigate the continuity of this function at $x = 2$

$$\begin{aligned} \lim_{x \rightarrow 2^+} f(x) &= \lim_{x \rightarrow 2^+} x^2 + 1 && \text{(because } x^2 + 1 \text{ is the function for the domain } x \text{ greater than } 2) \\ &= 5 \end{aligned}$$

$$\begin{aligned} \lim_{x \rightarrow 2^-} f(x) &= \lim_{x \rightarrow 2^-} 2x + 1 && \text{(because } 2x + 1 \text{ is the function for the domain } x \text{ less than } 2) \\ &= 5 \end{aligned}$$

So as $\lim_{x \rightarrow 2^+} f(x) = \lim_{x \rightarrow 2^-} f(x) = 5$, we can say that the $\lim_{x \rightarrow 2} f(x)$ exists and equals 5.

But is the graph continuous at $x = 2$?

Obviously no, because when $x = 2$ exactly, the value of the function is given as 4.

So the functional value at $x = 2$ does not equal the limit at $x = 2$.

So this provides us with the definition of continuity that you need to know for this level of mathematics.

A function $f(x)$ is **continuous** at some point $x = a$ iff these three conditions are met

$$1. \quad \lim_{x \rightarrow a^+} f(x) = \lim_{x \rightarrow a^-} f(x) = \text{single number}$$

See Note 1

$$\text{i.e.} \quad \lim_{x \rightarrow a} f(x) \text{ exists;}$$

2. $f(a)$ is defined; and

$$3. \quad f(a) = \lim_{x \rightarrow a} f(x)$$

Make sure you understand these conditions.

Example 2.21:

Discuss the limit and continuity of $f(x)$ at $x = 1$ if

$$f(x) = \begin{cases} 1 & \text{for } x > 1 \\ x & \text{for } x < 1 \end{cases}$$

Solution:

$$\lim_{x \rightarrow 1^+} f(x) = \lim_{x \rightarrow 1^+} 1 = 1$$

$$\lim_{x \rightarrow 1^-} f(x) = \lim_{x \rightarrow 1^-} x = 1$$

$$\therefore \lim_{x \rightarrow 1} f(x) = 1$$

But the function is not defined at $x = 1$ \therefore the function is not continuous at $x = 1$.

See Note 2

Notes

1. 'Iff' is read as 'if and only if'.
2. Careful examination of the domain is required when several functions define $f(x)$.

Exercise Set 2.18

1. Complete each table and use it to intuitively find the required limit.

(i)

x	-1.1	-1.01	-1.001	-0.999	-0.99	-0.9
$f(x) = x^2 - 2$						

$$\lim_{x \rightarrow -1} (x^2 - 2) = ?$$

(ii)

x	-0.2	-0.1	-0.01	0.01	0.1	0.2
$f(x) = \frac{x^2 + x}{x}$						

$$\lim_{x \rightarrow 0} \frac{x^2 + x}{x} = ?$$

(iii)

x	-2.5	-2.9	-2.99	-3.01	-3.1	-3.5
$f(x) = \frac{x^2 - 9}{x + 3}$						

$$\lim_{x \rightarrow -3} \frac{x^2 - 9}{x + 3} = ?$$

(iv)

x (radian)	-0.2	-0.1	-0.01	0.01	0.1	0.2
$f(x) = \frac{\tan x}{x}$						

$$\lim_{x \rightarrow 0} \frac{\tan x}{x} = ?$$

2. Examine each graph and determine whether the $\lim_{x \rightarrow c} f(x)$ exists. Explain your reasoning.

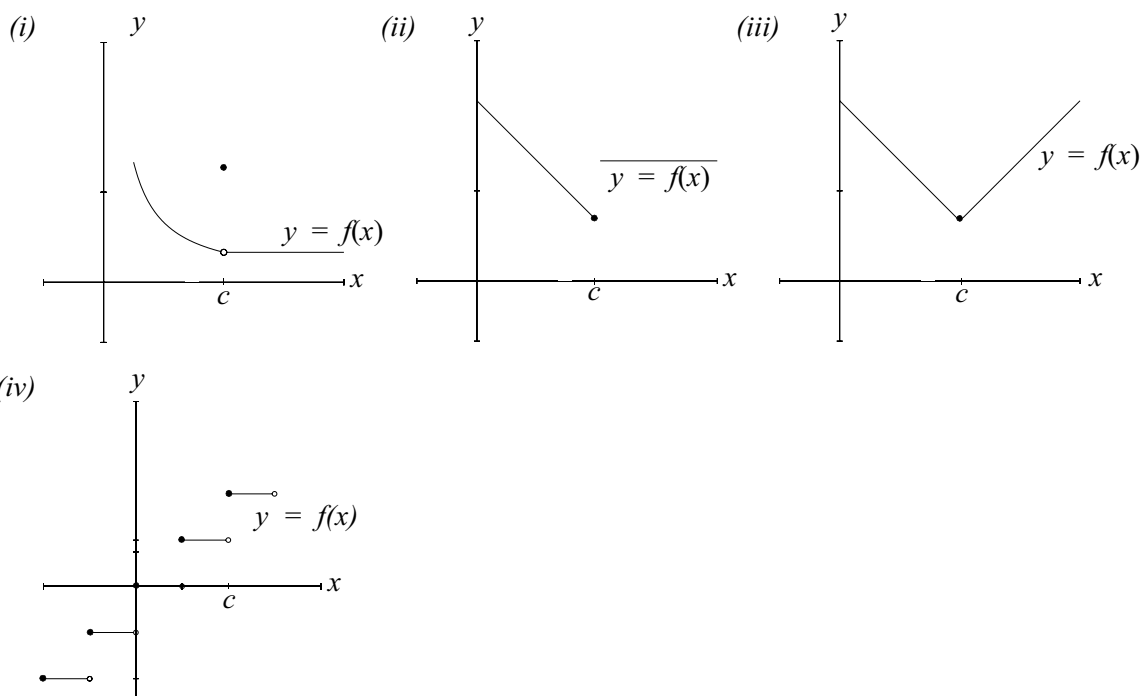

3. Determine whether $f(x)$ is continuous at the point $x = c$.

$$(i) \quad f(x) = \begin{cases} 2x + 1 & \text{if } x \leq 0 \\ 2x & \text{if } x > 0 \end{cases} \quad c = 0$$

$$(ii) \quad f(x) = \begin{cases} 3x - 1 & \text{if } x < 1 \\ 2 & \text{if } x = 1 \\ 2x & \text{if } x > 1 \end{cases} \quad c = 1$$

$$(iii) \quad f(x) = \begin{cases} x^2 + 4 & \text{if } x < -1 \\ 2 & \text{if } x = -1 \\ -3x + 2 & \text{if } x > -1 \end{cases} \quad c = -1$$

4. Discuss the continuity of the function

$$f(x) = \begin{cases} 2x + 1 & \text{for } 0 \leq x \leq 2 \\ 7 - x & \text{for } 2 < x < 4 \\ x & \text{for } 4 \leq x \leq 6 \end{cases}$$

Solutions to Exercise Sets

Solutions Exercise Set 2.1 page 2.2

1. (a) $-\frac{1}{4} < 0.25$
- (b) $-\sqrt{2} > -\sqrt{3}$
- (c) $\pi < \frac{22}{7}$
- (d) $0.00012 = 1.2 \times 10^{-4}$
- (e) $2.7 < e$

Solutions Exercise Set 2.2 page 2.4

1. $x \leq 4$ has the solution set ‘any real number **less than or equal to 4**’ or in interval notation, $(-\infty, 4]$
 e.g. $-180, -\sqrt{7}, -\pi, 2, 2.41, \pi, e, \frac{10}{3}, \sqrt{2}$
2. $-2 < y$ has the solution set ‘any real number **greater than -2** ’ or in interval notation $(-2, \infty)$
 e.g. $1\ 000, 49.2, \pi, e^2, 2.111, 6\frac{2}{9}$
3. $-\frac{1}{2} \leq p \leq 3$ has the solution set ‘any real number **between $-\frac{1}{2}$ and 3 and including $-\frac{1}{2}$ and 3**’ or in interval notation $\left[-\frac{1}{2}, 3\right]$
 e.g. $-\frac{1}{2}, -0.499, -0.21, -\frac{1}{5}, 0, 1, 2, 2.48, 3$

Solutions Exercise Set 2.3 page 2.7

1. $2x + 4 \leq 8$

$$\therefore 2x \leq 8 - 4$$

$$\therefore 2x \leq 4$$

$$\therefore x \leq 2 \quad \text{or} \quad (-\infty, 2]$$

Check: Choose say $x = 1$

See Note 1

$$\therefore \text{LHS} = 2x + 4 = 2 \times 1 + 4 = 6 \quad \text{and}$$

$$\text{RHS} = 8 \quad \therefore \text{LHS} \leq \text{RHS} \quad \checkmark$$

2. $-\frac{1}{2}p > 2p + 4$

$$\therefore -\frac{1}{2}p - 2p > 4$$

$$-\frac{5}{2}p > 4$$

$$\therefore p < 4 \times \frac{-2}{5}$$

[Note the change in direction of the inequality]

$$\therefore p < \frac{-8}{5} \quad \text{or} \quad \left(-\infty, \frac{-8}{5}\right)$$

Check: Choose say $x = -3$

$$\therefore \text{LHS} = -\frac{1}{2}p = -\frac{1}{2} \times -3 = \frac{3}{2} \quad \text{and}$$

$$\text{RHS} = 2p + 4 = 2 \times -3 + 4 = -2$$

$$\therefore \text{LHS} > \text{RHS} \quad \checkmark$$

3. $2d + 2 \leq 4d - 3$

$$\therefore 2d - 4d \leq -3 - 2$$

$$\therefore -2d \leq -5$$

[Note the change in direction of the inequality]

$$\therefore d \geq \frac{5}{2} \quad \text{or} \quad \left[\frac{5}{2}, +\infty\right)$$

Check: Choose say $d = 4$

$$\therefore \text{LHS} = 2d + 2 = 2 \times 4 + 2 = 10 \quad \text{and}$$

$$\text{RHS} = 4d - 3 = 4 \times 4 - 3 = 13$$

$$\therefore \text{LHS} \leq \text{RHS} \quad \checkmark$$

Notes

1. Choosing one particular value of x does not **prove** the solution is true but it does help in the checking process.

Solutions Exercise Set 2.3 cont.

4. $3y - 2 \geq 4y + 6$

$$\therefore 3y - 4y \geq 6 + 2$$

$$\therefore -y \geq 8$$

$$\therefore y \leq -8 \quad \text{or} \quad (-\infty, -8] \quad \text{[Note the change in direction of the inequality]}$$

Check: Choose say $y = -10$

$$\therefore \text{LHS} = 3y - 2 = 3 \times -10 - 2 = -32 \quad \text{and}$$

$$\text{RHS} = 4y + 6 = 4 \times -10 + 6 = -34$$

$$\therefore \text{LHS} \geq \text{RHS} \quad \checkmark$$

5. $2y(3 - y) > (6 - y)(3 + 2y)$

$$6y - 2y^2 > 18 + 12y - 3y - 2y^2$$

[Using the Distributive Law]

$$\therefore 6y - 2y^2 - 12y + 3y + 2y^2 > 18$$

$$\therefore -3y > 18$$

$$\therefore y < -6 \quad \text{or} \quad (-\infty, -6)$$

Check: Choose say $y = -7$

$$\therefore \text{LHS} = 2 \times -7(3 - -7) = -14 \times 10 = -140$$

$$\text{RHS} = (6 - -7)(3 + 2 \times -7) = 13 \times -11 = -143$$

$$\therefore \text{LHS} > \text{RHS} \quad \checkmark$$

6. $|2x + 4| < 3$

Absolute value of $2x + 4$ is less than 3 means

$$2x + 4 < 3 \quad \text{and} \quad -(2x + 4) < 3$$

$$\therefore 2x < -1 \quad \text{and} \quad \therefore 2x - 4 < 3$$

$$\therefore x < -\frac{1}{2} \quad \text{and} \quad \therefore -2x < 7$$

$$\therefore x > \frac{-7}{2}$$

$$\therefore -\frac{7}{2} < x < -\frac{1}{2} \quad \text{or} \quad \left(-\frac{7}{2}, -\frac{1}{2}\right)$$

Solutions Exercise Set 2.4 page 2.14

1. (a) Draw the **equalities** i.e. the lines $4x + 5y = 20$ Determine any two points (It is easiest to find the x and y intercept)
 e.g. (0, 4) and (5, 0)
- $2x + 6y = 18$ Determine any two points
 (e.g. (0, 3) and 9, 0)
- $x = 0$ } These restrict the solution to the first quadrant.
 $y = 0$ }

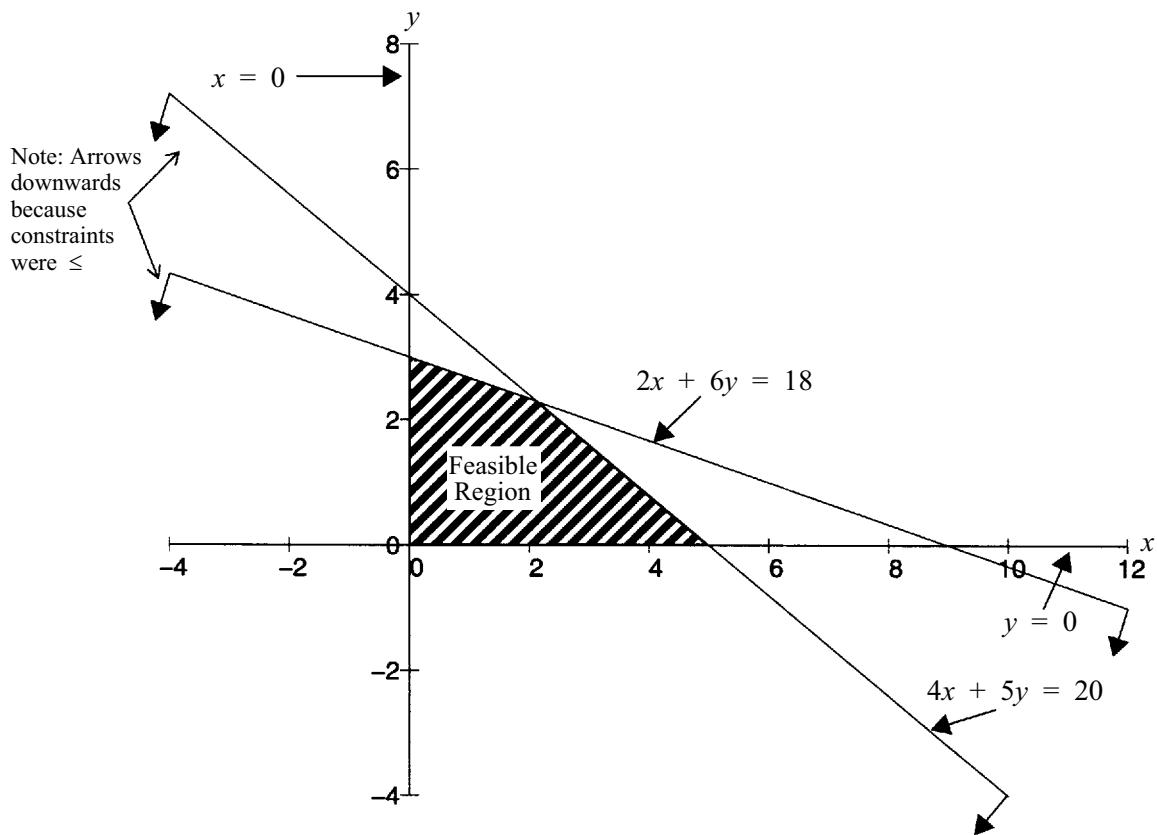

Any point in the shaded region will satisfy all the inequalities. To help check choose any point inside shaded region and check the inequalities. Choose say (3, 1).

Consider when $x = 3$ and $y = 1$

- $4x + 5y \leq 20$; LHS = $4 \times 3 + 5 \times 1 = 17$ which is \leq RHS of 20 ✓
- $2x + 6y \leq 18$; LHS = $2 \times 3 + 6 \times 1 = 12$ which is \leq RHS of 18
- $x \geq 0$ and $y \geq 0$ are obviously satisfied

Solutions Exercise Set 2.4 cont.

1. (b) The **equalities** are $x + y = 6$ Points for plotting: (0, 6), (6, 0)
 $10x + 2y = 20$ (0, 10), (2, 0)
 $y = 2$ [Care needs to be taken here]
 $x = 0$

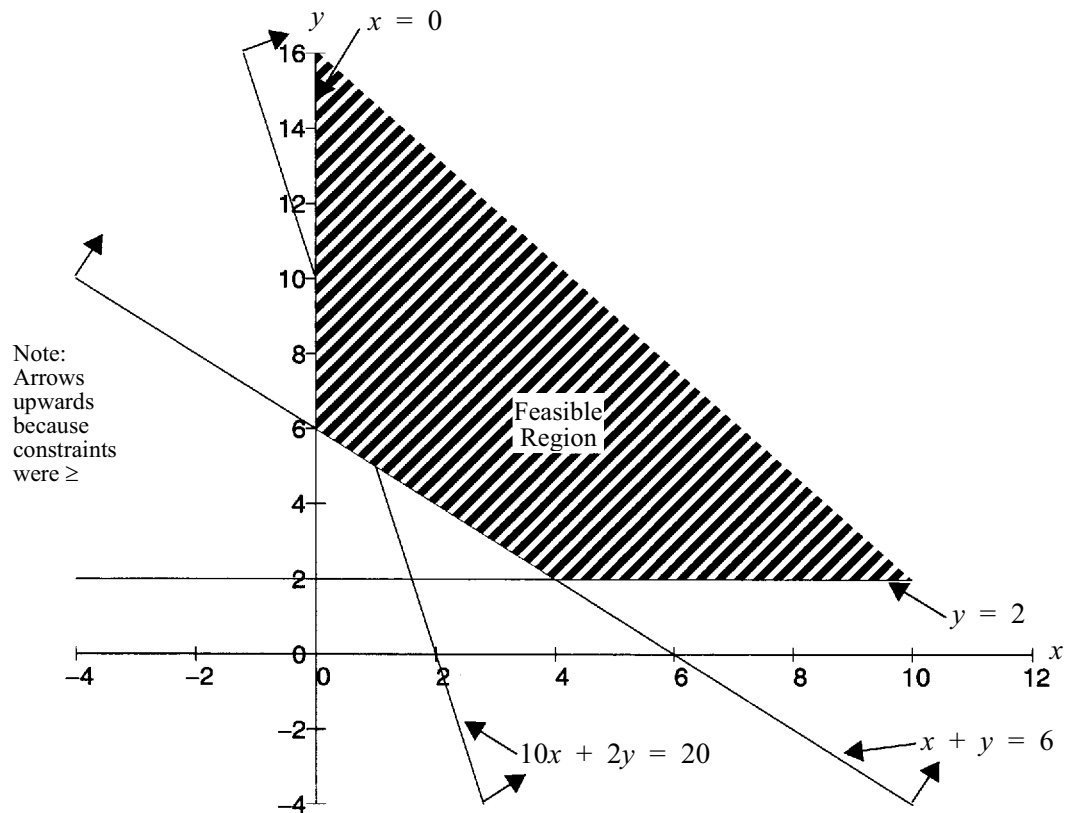

Checking: Consider a point in the region, say (6, 4)

When $x = 6$ and $y = 4$

- $x + y \geq 6$; LHS = $6 + 4 = 10$ which is \geq RHS of 6 ✓
- $10x + 2y \geq 20$; LHS = $10 \times 6 + 2 \times 4 = 68$ which is \geq RHS of 20
- $y \geq 2$ and $x \geq 0$ are also satisfied

Solutions Exercise Set 2.4 cont.

2. Max $P = x + y$

Subject to: $2x + y \leq 8$

$x + 3y \leq 9$

$x \geq 0$

$y \geq 0$

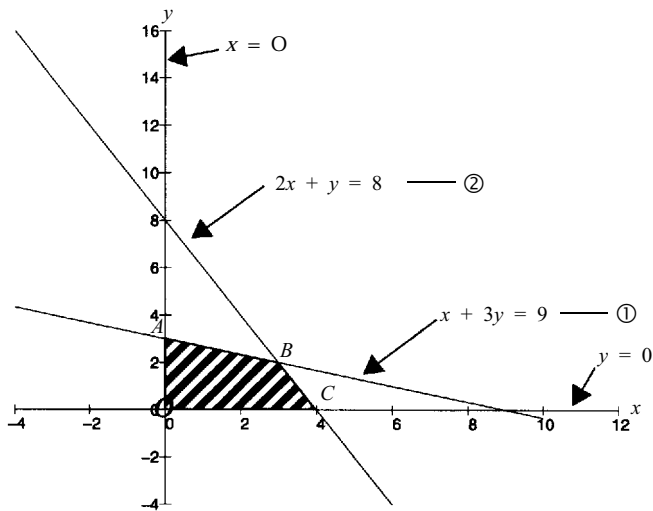

Constraints have been plotted by finding the x and y intercepts.

For ①, (0, 3) and (9, 0)

For ②, (0, 8) and (4, 0)

$P = x + y$ is maximised at one of the corner points i.e. at 0, A, B or C.

To find the co-ordinates of B **exactly** we solve simultaneously $x + 3y = 9$ and $2x + y = 8$. [Note: it is not good enough to simply read the points of intersection from the graph]

$$x + 3y = 9 \quad \text{①}$$

$$2x + y = 8 \quad \text{②}$$

$$\text{From ① } x = 9 - 3y \quad \text{③}$$

Substituting for x in ② gives

$$2(9 - 3y) + y = 8$$

$$\therefore 18 - 6y + y = 8$$

$$\therefore -5y = -10$$

$$\therefore y = 2$$

Substituting for y in ③ gives

$$x = 9 - 3 \times 2 = 3$$

$$\therefore \text{Point B is } (3, 2)$$

Solutions Exercise Set 2.4 cont.

2. continued

Point	Co Ord	$P = x + y$
O	(0, 0)	$0 + 0 = 0$
A	(0, 3)	$0 + 3 = 3$
B	(3, 2)	$3 + 2 = 5$ * maximum
C	(4, 0)	$4 + 0 = 4$

The function $P = x + y$ is maximised (under the given constraints) when $x = 3$ and $y = 2$.

3. Let x be the no. of kg of regular sausages made and y be the no. of kg of deluxe sausages made.

We seek to maximise profit, P (in dollars)

i.e. $\text{Max } P = 0.6x + 0.8y$

Subject to $0.2x + 0.4y \leq 60$ {beef availability}

$0.2x + 0.2y \leq 40$ {pork availability}

$x \geq 0$
 $y \geq 0$ {non-negativity constraints}

$0.2x + 0.4y = 60$ – ① $\rightarrow (0, 150), (300, 0)$
 $0.2x + 0.2y = 40$ – ② $\rightarrow (0, 200), (200, 0)$ {Points for plotting equalities}

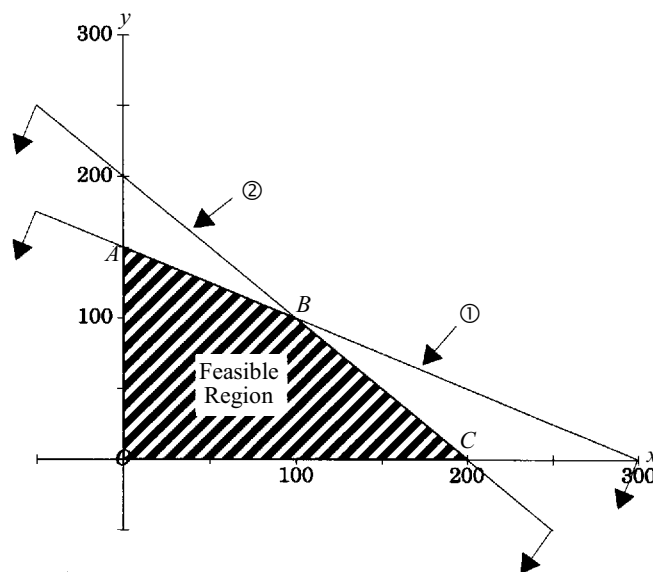

Solutions Exercise Set 2.4 cont.

3. continued

 $P = 0.6x + 0.8y$ will be maximised at 0, A, B or C

Co Ords of B are given by solving simultaneously

$$0.2x + 0.4y = 60 \quad \textcircled{1}$$

$$0.2x + 0.2y = 40 \quad \textcircled{2}$$

From $\textcircled{1}$ $0.2x = 60 - 0.4y$

$$\therefore x = 300 - 2y \quad \textcircled{3}$$

Substituting for x in $\textcircled{2}$ gives

$$0.2(300 - 2y) + 0.2y = 40$$

$$\therefore 60 - 0.4y + 0.2y = 40$$

$$-0.2y = -20$$

$$\therefore y = 100$$

Substituting for y in $\textcircled{3}$ gives

$$x = 300 - 2 \times 100$$

$$\therefore x = 100$$

 \therefore Point B is (100, 100)

Point	Co Ords	$P = 0.6x + 0.8y$
0	(0, 0)	$0.6 \times 0 + 0.8 \times 0 = 0$
A	(0, 150)	$0.6 \times 0 + 0.8 \times 150 = 120$
B	(100, 100)	$0.6 \times 100 + 0.8 \times 100 = 140$ * maximum
C	(200, 0)	$0.6 \times 200 + 0.8 \times 0 = 120$

\therefore The butcher will maximise profit on sausages (given the amount of pork and beef available) at \$140, when 100 kg of regular sausages and 100 kg of deluxe sausages are made.

Solutions Exercise Set 2.4 cont.

4. Let x be the number of thousands of dollars invested in stock A and y be the number of thousands of dollars invested in stock B. We seek to maximise R , the return on the investment (in thousands of dollars).

i.e. $\text{Max } R = 0.12x + 0.15y$

- Subject to $x \leq 80$ { no more than \$80 000 in stock A }
- $y \geq 12$ { at least \$12 000 in stock B }
- $y \leq \frac{1}{3}x$ { at least three times as much in conservative stock as in speculative stock }
- $x + y \leq 100$ { \$100 000 total available for investment }
- $x \geq 0$ { non-negativity constraints }
- $y \geq 0$

- $x = 80$ _____ ① line parallel with y -axis with x intercept $(80, 0)$
- $y = 12$ _____ ② line parallel with x -axis with y intercept $(0, 12)$
- $-\frac{1}{3}x + y = 0$ _____ ③ $\rightarrow (0, 0), (30, 10)$ {any other points will do}
- $x + y = 100$ _____ ④ $\rightarrow (0, 100), (100, 0)$

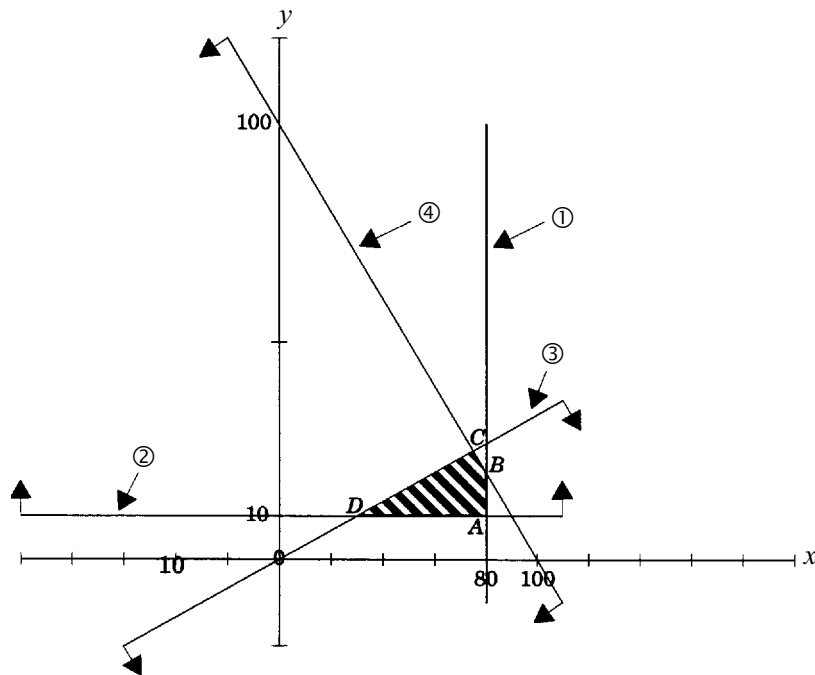

Solutions Exercise Set 2.4 cont.

4. continued

 $R = 0.12x + 0.15y$ will be maximised at A, B, C or D

Co Ords of A are given by solving simultaneously

$$x = 80 \text{ ——— } \textcircled{1}$$

$$y = 12 \text{ ——— } \textcircled{2}$$

 \therefore Point A is (80, 12)

Co Ords of B are given by solving simultaneously

$$x = 80 \text{ ——— } \textcircled{1}$$

$$x + y = 100 \text{ ——— } \textcircled{4}$$

Substituting for x in $\textcircled{4}$ gives

$$80 + y = 100$$

$$\therefore y = 20$$

 \therefore Point B is (80, 20)

Co Ords of C are given by solving simultaneously

$$-\frac{1}{3}x + y = 0 \text{ ——— } \textcircled{3}$$

$$x + y = 100 \text{ ——— } \textcircled{4}$$

Subtracting $\textcircled{3}$ from $\textcircled{4}$

$$\therefore \frac{4x}{3} = 100$$

$$\therefore x = \frac{300}{4} = 75$$

Substituting in $\textcircled{4}$ for x gives

$$75 + y = 100$$

$$\therefore y = 25$$

 \therefore Point C is (75, 25)

Co Ords of D are given by solving simultaneously

$$y = 12 \text{ ——— } \textcircled{2}$$

$$-\frac{1}{3}x + y = 0 \text{ ——— } \textcircled{3}$$

Substituting in $\textcircled{3}$ for y gives

$$-\frac{1}{3}x + 12 = 0$$

$$\therefore x = 36$$

 \therefore Point D is (36, 12)

Solutions Exercise Set 2.4 cont.

4. continued

Point	Co Ords	$R = 0.12x + 0.15y$
A	(80, 12)	$0.12 \times 80 + 0.15 \times 12 = 11.4$
B	(80, 20)	$0.12 \times 80 + 0.15 \times 20 = 12.6$
C	(75, 25)	$0.12 \times 75 + 0.15 \times 25 = 12.75$ * maximum
D	(36, 12)	$0.12 \times 36 + 0.15 \times 12 = 6.12$

The managers will receive the highest return of \$12 750 per annum when \$75 000 is invested in stock A and \$25 000 is invested in stock B.

Solutions Exercise Set 2.5 page 2.20

1. (a) $x^2 - 8x = 0$
 $\therefore x(x - 8) = 0$
 $\therefore x = 0$ or $x = 8$ Check by substituting each value of x into the **original** equation

(b) $x^2 - 2x - 24 = 0$
 $\therefore (x - 6)(x + 4) = 0$
 $\therefore x = 6$ or $x = -4$ Always check solutions

(c) $6x^2 - x - 12 = 0$
 $\therefore 6\left(x^2 - \frac{1}{6}x - 2\right) = 0$ { Can factorise out 6 on the LHS because the RHS is zero }
 $\therefore x^2 - \frac{1}{6}x - 2 = 0$ {Use the quadratic formula to solve if you can't 'see' the factors.}
 $\therefore \left(x + \frac{4}{3}\right) \left(x - \frac{3}{2}\right) = 0$
 $\therefore x = \frac{-4}{3}$ or $x = \frac{3}{2}$ Check solutions

(d) $9x^2 + 6x + 1 = 0$

$$x = \frac{-b \pm \sqrt{b^2 - 4ac}}{2a}$$

$$= \frac{-6 \pm \sqrt{36 - 36}}{18}$$
 Only one solution for x. Check its validity.
 $\therefore x = \frac{-6}{18} = \frac{-1}{3}$

Solutions Exercise Set 2.5 cont.

1. (e) $2x^2 - 3 = 0$

$$\therefore 2x^2 = 3$$

$$\therefore x^2 = \frac{3}{2}$$

$$\therefore x = +\sqrt{\frac{3}{2}} \text{ or } x = -\sqrt{\frac{3}{2}}$$

Always remember the positive and negative root.

(f) $7x^2 - 12x + 7 = 0$

$$x = \frac{+12 \pm \sqrt{144 - 196}}{14}$$

Negative under square root which is impossible

 \therefore No real solution for this equation

(g) $-2x^2 - x + 2 = 0$

$$\therefore 2x^2 + x - 2 = 0$$

$$x = \frac{-1 \pm \sqrt{1 + 16}}{4}$$

$$= \frac{-1 \pm \sqrt{17}}{4}$$

$$\therefore x = \frac{-1 + \sqrt{17}}{4} \text{ or } x = \frac{-1 - \sqrt{17}}{4}$$

$$\therefore x \approx 0.7808 \text{ or } x \approx -1.2808$$

2. (a) If $x = -\frac{2}{3}$ and $x = 5$ and these are the roots of $ax^2 + bx + c = 0$

$$\text{then } \left(x + \frac{2}{3}\right) (x - 5) = 0$$

$$\text{i.e. } x^2 - 5x + \frac{2x}{3} - \frac{10}{3} = 0$$

$$\text{i.e. } x^2 - \frac{13x}{3} - \frac{10}{3} = 0 \text{ or } 3x^2 - 13x - 10 = 0$$

Use the quadratic formula to check that the roots of this equation are $x = -\frac{2}{3}$ and $x = 5$.

Solutions Exercise Set 2.5 cont.

2. (b) If $x = \frac{1}{3}$ is a repeated root of the equation $ax^2 + bx + c = 0$

$$\text{then } \left(x - \frac{1}{3}\right) \left(x - \frac{1}{3}\right) = 0$$

$$\text{i.e. } x^2 - \frac{1}{3}x - \frac{1}{3}x + \frac{1}{9} = 0$$

$$\text{i.e. } x^2 - \frac{2}{3}x + \frac{1}{9} = 0 \quad \text{or} \quad 9x^2 - 6x + 1 = 0$$

Compare this equation to Q1. (d).

- (c) If $x = \frac{-3-\sqrt{2}}{4}$ and $x = \frac{-3+\sqrt{2}}{4}$ and these are the roots of $ax^2 + bx + c = 0$

$$\text{then } \left(x - \left(\frac{-3-\sqrt{2}}{4}\right)\right) \left(x - \left(\frac{-3+\sqrt{2}}{4}\right)\right) = 0$$

$$\text{i.e. } x^2 - x\left(\frac{-3+\sqrt{2}}{4}\right) - x\left(\frac{-3-\sqrt{2}}{4}\right) + \left(\frac{-3+\sqrt{2}}{4}\right) \left(\frac{-3-\sqrt{2}}{4}\right) = 0$$

$$\text{i.e. } x^2 + \frac{3x}{4} - \frac{\sqrt{2}x}{4} + \frac{3x}{4} + \frac{\sqrt{2}x}{4} + \frac{9-2}{16} = 0$$

$$\text{i.e. } x^2 + \frac{3x}{2} + \frac{7}{16} = 0 \quad \text{or} \quad 16x^2 + 24x + 7 = 0$$

Although I have not shown the checking for each of these problems you should ensure that you routinely do check.

Solutions Exercise Set 2.6 page 2.20

1. (a) $(x+3)^2 = x^2 + 3x + 3x + 3^2 = x^2 + 6x + 9$
 (b) $(x+4)^2 = x^2 + 4x + 4x + 4^2 = x^2 + 8x + 16$
 (c) $\left(x + \frac{1}{2}\right)^2 = x^2 + \frac{1}{2}x + \frac{1}{2}x + \left(\frac{1}{2}\right)^2 = x^2 + x + \frac{1}{4}$
 (d) $(x-2)^2 = x^2 - 2x - 2x + (-2)^2 = x^2 - 4x + 4$
 (e) $\left(x - \frac{3}{4}\right)^2 = x^2 - \frac{3}{4}x - \frac{3}{4}x + \left(-\frac{3}{4}\right)^2 = x^2 - \frac{3x}{2} + \frac{9}{16}$
 (f) $(2x-1)^2 = (2x)^2 - 2x - 2x + (-1)^2 = 4x^2 - 4x + 1$

Solutions Exercise Set 2.7 page 2.21

1. (b) $x^2 + 8x$ can come from $(x + 4)^2$

Coefficient of x in $x^2 + 8x$ is 8 and half of 8 is 4.

Now $(x + 4)^2 = x^2 + 8x + 16$

$$\therefore x^2 + 8x = (x + 4)^2 - 16$$

(c) $x^2 + x$ can come from $\left(x + \frac{1}{2}\right)^2$

Coefficient of x in $x^2 + x$ is 1 and half of 1 is $\frac{1}{2}$.

Now $\left(x + \frac{1}{2}\right)^2 = x^2 + x + \frac{1}{4}$

$$\therefore x^2 + x = \left(x + \frac{1}{2}\right)^2 - \frac{1}{4}$$

(d) $x^2 - 4x$ can come from $(x - 2)^2$

Coefficient of x in $x^2 - 4x$ is -4 and half of -4 is -2 .

Now $(x - 2)^2 = x^2 - 4x + 4$

$$x^2 - 4x = (x - 2)^2 - 4$$

(e) $x^2 - \frac{3}{2}x$ can come from $\left(x - \frac{3}{4}\right)^2$

Coefficient of x in $x^2 - \frac{3}{2}x$ is $-\frac{3}{2}$ and half of $-\frac{3}{2}$ is $-\frac{3}{4}$.

Now $\left(x - \frac{3}{4}\right)^2 = x^2 - \frac{3}{2}x + \frac{9}{16}$

$$\therefore x^2 - \frac{3}{2}x = \left(x - \frac{3}{4}\right)^2 - \frac{9}{16}$$

(f) $4x^2 - 4x$ can come from $(2x - 1)^2$

Coefficient of x in $4x^2 - 4x$ is -4 but the coefficient of x^2 is 4 \therefore constant in the perfect square must reflect this.

Now $(2x - 1)^2 = 4x^2 - 4x + 1$

$$\therefore 4x^2 - 4x = (2x - 1)^2 - 1$$

2. $x^2 + \frac{7}{8}x$ comes from $\left(x + \frac{7}{16}\right)^2$ and $\left(x + \frac{7}{16}\right)^2 = x^2 + \frac{7}{8}x + \frac{49}{256}$

$$\therefore x^2 + \frac{7}{8}x = \left(x + \frac{7}{16}\right)^2 - \frac{49}{256}$$

Checking: $\left(x + \frac{7}{16}\right)^2 - \frac{49}{256} = x^2 + \frac{7}{8}x + \frac{49}{256} - \frac{49}{256} = x^2 + \frac{7}{8}x \quad \checkmark$

Solutions Exercise Set 2.8 cont.

$$3. \quad 2x^2 + x \text{ comes from } 2\left\{\left(x + \frac{1}{4}\right)^2\right\} \text{ and } 2\left\{\left(x + \frac{1}{4}\right)^2\right\} = 2\left\{x^2 + \frac{1}{2}x + \frac{1}{16}\right\}$$

$$\therefore 2x^2 + x = 2\left\{\left(x + \frac{1}{4}\right)^2 - \frac{1}{16}\right\} = 2\left(x + \frac{1}{4}\right)^2 - \frac{1}{8}$$

$$\text{Checking: } 2\left(x + \frac{1}{4}\right)^2 - \frac{1}{8} = 2\left(x^2 + \frac{1}{2}x + \frac{1}{16}\right) = 2x^2 + x + \frac{1}{8} - \frac{1}{8} = 2x^2 + x \quad \checkmark$$

$$4. \quad kx^2 + x \text{ comes from } k\left\{\left(x + \frac{1}{2k}\right)^2\right\} \text{ and } k\left\{\left(x + \frac{1}{2k}\right)^2\right\} = k\left\{x^2 + \frac{1}{k}x + \frac{1}{4k^2}\right\}$$

$$\therefore kx^2 + x = k\left\{\left(x + \frac{1}{2k}\right)^2 - \frac{1}{4k^2}\right\} = k\left(x + \frac{1}{2k}\right)^2 - \frac{1}{4k}$$

$$\text{Checking: } k\left(x + \frac{1}{2k}\right)^2 - \frac{1}{4k} = k\left(x^2 + \frac{x}{k} + \frac{1}{4k^2}\right) - \frac{1}{4k}$$

$$= kx^2 + x + \frac{1}{4k} - \frac{1}{4k} = kx^2 + x \quad \checkmark$$

$$5. \quad x^2 - 8x \text{ comes from } (x - 4)^2 \text{ and } (x - 4)^2 = x^2 - 8x + 16$$

$$\therefore x^2 - 8x = (x - 4)^2 - 16$$

$$\text{Checking: } (x - 4)^2 - 16 = x^2 - 8x + 16 - 16 = x^2 - 8x$$

$$6. \quad x^2 - 9x \text{ comes from } \left(x - \frac{9}{2}\right)^2 \text{ and } \left(x - \frac{9}{2}\right)^2 = x^2 - 9x + \frac{81}{4}$$

$$\therefore x^2 - 9x = \left(x - \frac{9}{2}\right)^2 - \frac{81}{4}$$

$$\text{Checking: } \left(x - \frac{9}{2}\right)^2 - \frac{81}{4} = x^2 - 9x + \frac{81}{4} - \frac{81}{4} = x^2 - 9x \quad \checkmark$$

$$7. \quad x^2 - ax \text{ comes from } \left(x - \frac{a}{2}\right)^2 \text{ and } \left(x - \frac{a}{2}\right)^2 = x^2 - ax + \frac{a^2}{4}$$

$$\therefore x^2 - ax = \left(x - \frac{a}{2}\right)^2 - \frac{a^2}{4}$$

$$\text{Checking: } \left(x - \frac{a}{2}\right)^2 - \frac{a^2}{4} = x^2 - ax + \frac{a^2}{4} - \frac{a^2}{4} = x^2 - ax \quad \checkmark$$

Solutions Exercise Set 2.9 page 2.28

1. (i) $x^2 + 8x - 4 = (x + 4)^2 - 16 - 4 = (x + 4)^2 - 20$

(ii) Checking: $(x + 4)^2 - 20 = x^2 + 8x + 16 - 20 = x^2 + 8x - 4 \quad \checkmark$

(iii) If $x^2 + 8x - 4 = 0$, then $(x + 4)^2 - 20 = 0$

i.e. $(x + 4)^2 = 20$

$\therefore x + 4 = \pm\sqrt{20}$

$\therefore x = -4 + \sqrt{20}$ or $x = -4 - \sqrt{20}$

i.e. $x = -4 + 2\sqrt{5}$ or $x = -4 - 2\sqrt{5}$

i.e. $x \approx 0.4721$ or $x \approx -8.4721$

See Note 1

(iv) Checking: When $x = 0.4721$, LHS = $x^2 + 8x - 4 = (0.4721^2) + 8 \times 0.4721 - 4 \approx$ RHS \checkmark

2. (i) $x^2 + 4x + 9 = (x + 2)^2 - 4 + 9 = (x + 2)^2 + 5$

(ii) Checking: $(x + 2)^2 + 5 = x^2 + 4x + 4 + 5 = x^2 + 4x + 9 \quad \checkmark$

(iii) If $x^2 + 4x + 9 = 0$, then $(x + 2)^2 + 5 = 0$

i.e. $(x + 2)^2 = -5$ It is impossible for a square to give -5 , so there is no solution to the quadratic $x^2 + 4x + 9 = 0$. (Geometrically, this means the graph of $y = x^2 + 4x + 9$ does not cut the x -axis.)

(iv) Checking can be done by graphing $y = x^2 + 4x + 9$

3. (i) $-8x^2 + 16x - 4 = -8\left\{x^2 - 2x + \frac{1}{2}\right\} = -8\left\{(x - 1)^2 - 1 + \frac{1}{2}\right\}$

$= -8\left\{(x - 1)^2 - \frac{1}{2}\right\} = -8(x - 1)^2 + 4$

(ii) Checking: $-8(x - 1)^2 + 4 = -8(x^2 - 2x + 1) + 4 = -8x^2 + 16x - 8 + 4 = -8x^2 + 16x - 4 \quad \checkmark$

Notes

1. You can check using the surd form or convert to decimals (a very small rounding error may occur).

Solutions Exercise Set 2.9 cont.

3. (iii) If $-8x^2 + 16x - 4 = 0$, then $-8(x-1)^2 + 4 = 0$

i.e. $-8(x-1)^2 = -4$

$\therefore (x-1)^2 = \frac{1}{2}$

$\therefore x-1 = \pm\sqrt{\frac{1}{2}}$

$\therefore x = 1 \pm \sqrt{\frac{1}{2}}$

$\therefore x = 1 + \sqrt{\frac{1}{2}}$ or $x = 1 - \sqrt{\frac{1}{2}}$

i.e. $x \approx 1.7071$ or $x \approx 0.2929$

(iv) Checking: When $x = 1.7071$, LHS = $-8x^2 + 16x - 4 = -8 \times 1.7071^2 + 16 \times 1.7071 - 4$
 $\approx 0 = \text{RHS } \checkmark$

When $x = 0.2929$, LHS = $-8 \times 0.2929^2 + 16 \times 0.2929 - 4 \approx 0 = \text{RHS } \checkmark$

4. (i) $-3x^2 + 6x + 4 = -3\left\{x^2 - 2x - \frac{4}{3}\right\} = -3\left\{(x-1)^2 - 1 - \frac{4}{3}\right\}$
 $= -3\left\{(x-1)^2 - \frac{7}{3}\right\} = -3(x-1)^2 + 7$

(ii) Checking: $-3(x-1)^2 + 7 = -3(x^2 - 2x + 1) + 7 = -3x^2 + 6x - 3 + 7 = -3x^2 + 6x + 4 \checkmark$

(iii) If $-3x^2 + 6x + 4 = 0$, then $-3(x-1)^2 + 7 = 0$

i.e. $-3(x-1)^2 = -7$

$\therefore (x-1)^2 = \frac{7}{3}$

$\therefore x-1 = \pm\sqrt{\frac{7}{3}}$

$\therefore x = 1 + \sqrt{\frac{7}{3}}$ or $x = 1 - \sqrt{\frac{7}{3}}$

i.e. $x \approx 2.5275$ or $x \approx -0.5275$

(iv) Checking: When $x = 2.5275$, LHS = $-3x^2 + 6x + 4 = -3 \times 2.5275^2 + 6 \times 2.5275 + 4$
 $\approx 0 = \text{RHS } \checkmark$

When $x = -0.5275$, LHS = $-3 \times (-0.5275)^2 + 6 \times -0.5275 + 4$
 $\approx 0 = \text{RHS } \checkmark$

Solutions Exercise Set 2.10 page 2.29

1. $P_1(x) = x + 4$

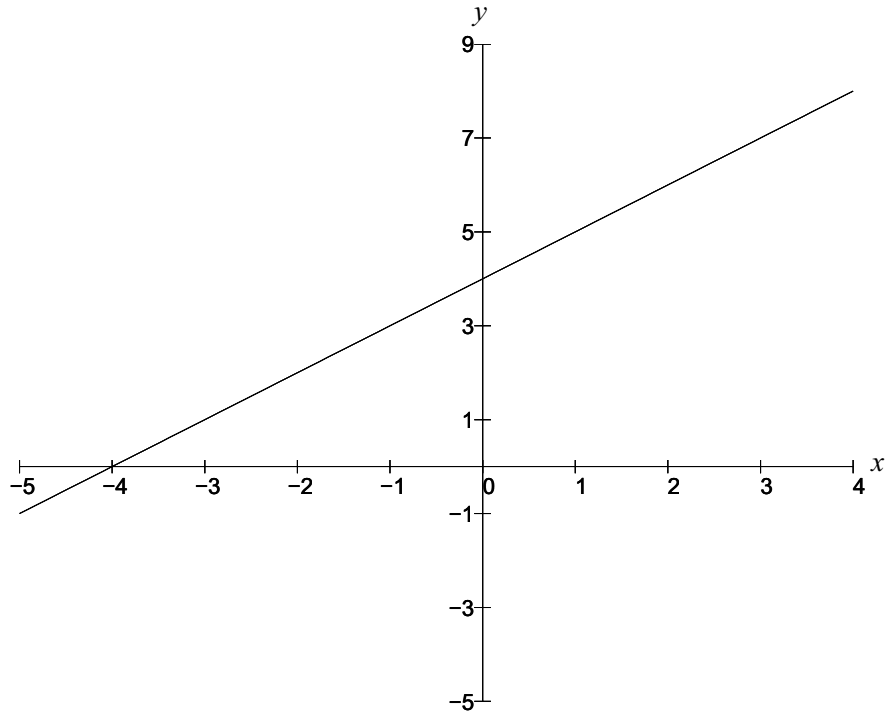

2. $P_2(x) = 8x^2 + 2x + 4$

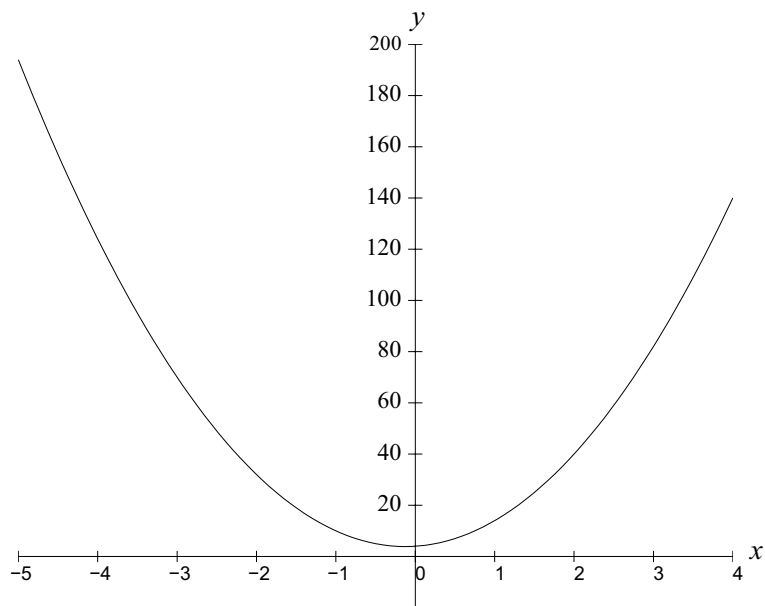

Solutions Exercise Set 2.10 cont.

3. $P_3(x) = 2x^3 + x^2 + 2x$

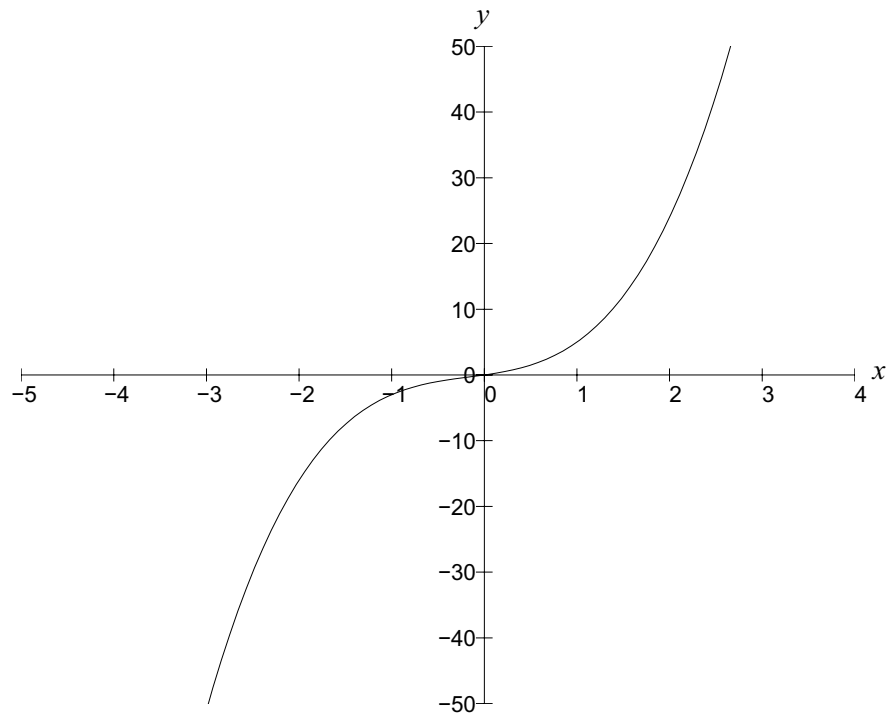

4. $P_4(x) = x^3 - 12x^2 + 3x + 4$

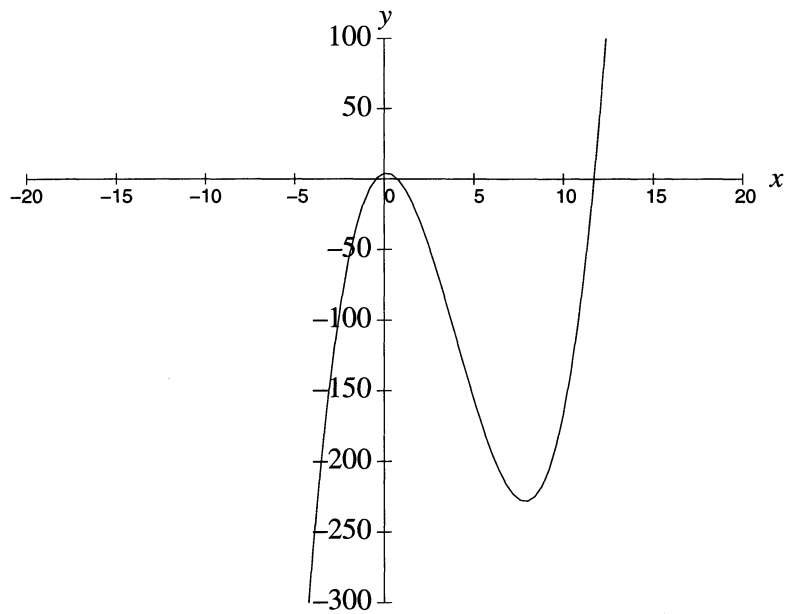

Solutions Exercise Set 2.11 page 2.32

1.

(a) $x^3 + 4x^2 - x - 4 = 0$

Try $x = 1$ as a solution: when $x = 1$, $\text{LHS} = 1^3 + 4 \times 1^2 - 1 - 4 = 0 = \text{RHS}$ So $x = 1$ is a solution and $(x - 1)$ is a factor.

Perform polynomial division to rewrite the original equation as the product of

 $(x - 1)$ and $(ax^2 + bx + c)$

$$\begin{array}{r}
 (x^2 + 5x + 4) \\
 (x - 1) \overline{) x^3 + 4x^2 - x - 4} \\
 \underline{x^3 - x^2} \\
 5x^2 - x \\
 \underline{5x^2 - 5x} \\
 4x - 4 \\
 \underline{4x - 4} \\
 0
 \end{array}$$

$$\therefore x^3 + 4x^2 - x - 4 = (x - 1)(x^2 + 5x + 4)$$

See Note 1

$$= (x - 1)(x + 4)(x + 1)$$

$$\therefore \text{As we are given } x^3 + 4x^2 - x - 4 = 0$$

$$\Rightarrow (x - 1)(x + 1)(x + 4) = 0$$

$$\Rightarrow x = 1 \text{ or } x = -4 \text{ or } x = -1$$

Checking: When $x = 1$, $x^3 + 4x^2 - x - 4 = 0$ ✓ (Proved valid earlier)

$$\text{When } x = -4, x^3 + 4x^2 - x - 4 = (-4)^3 + 4(-4)^2 - (-4) - 4 = 0 = \text{RHS} \quad \checkmark$$

$$\text{When } x = -1, x^3 + 4x^2 - x - 4 = (-1)^3 + 4(-1)^2 - (-1) - 4 = 0 = \text{RHS} \quad \checkmark$$

(b) $x^3 - 4x^2 + x + 6 = 0$

Try $x = 1$ as a solution: when $x = 1$, $\text{LHS} = 1^3 + 4 \times 1^2 + 1 + 6 = 4 \neq \text{RHS}$ $\therefore (x - 1)$ is not a factorTry $x = -1$ as a solution: when $x = -1$, $\text{LHS} = (-1)^3 - 4 \times (-1)^2 - 1 + 6 = 0 = \text{RHS}$ So $x = -1$ is a solution and $(x + 1)$ is a factor**Notes**

1. You can factorise the $(x^2 + 5x + 4)$ however you like. If you can't 'see' the factors, use the quadratic formula.

Solutions Exercise Set 2.11 cont.

1. (b) continued

$$\begin{array}{r}
 (x+1) \overline{) \begin{array}{r} x^3 - 4x^2 + x + 6 \\ x^3 + x^2 \\ \hline -5x^2 + x \\ -5x^2 - 5x \\ \hline 6x + 6 \\ 6x + 6 \\ \hline 0 \end{array} \\
 \hline
 \end{array}$$

$$\begin{aligned}
 \therefore x^3 - 4x^2 + x + 6 &= (x+1)(x^2 - 5x + 6) \\
 &= (x+1)(x-3)(x-2)
 \end{aligned}$$

$$\begin{aligned}
 \therefore \text{As we are given } x^3 - 4x^2 + x + 6 &= 0 \\
 \Rightarrow (x+1)(x-3)(x-2) &= 0 \\
 \Rightarrow x = -1, x = 3 \text{ or } x = 2
 \end{aligned}$$

Checking: When $x = -1$ has already been proved valid

$$\text{When } x = 3, x^3 - 4x^2 + x + 6 = 3^3 - 4 \times 3^2 + 3 + 6 = 0 = \text{RHS } \checkmark$$

$$\text{When } x = 2, x^3 - 4x^2 + x + 6 = 2^3 - 4 \times 2^2 + 2 + 6 = 0 = \text{RHS } \checkmark$$

(c) $2x^3 - 2x^2 - 8x + 8 = 0$

Try $x = 1$ as a solution: when $x = 1$, LHS = $2 \times 1^3 - 2 \times 1^2 - 8 \times 1 + 8 = 0 = \text{RHS}$ So $x = 1$ is a solution and $(x - 1)$ is a factor

$$\begin{array}{r}
 (x-1) \overline{) \begin{array}{r} 2x^3 - 2x^2 - 8x + 8 \\ 2x^3 - 2x^2 \\ \hline -8x + 8 \\ -8x + 8 \\ \hline 0 \end{array} \\
 \hline
 \end{array}$$

$$\begin{aligned}
 \therefore 2x^3 - 2x^2 - 8x + 8 &= (x-1)(2x^2 - 8) \\
 &= (x-1) \times 2(x^2 - 4) \\
 &= (x-1) \times 2(x-2)(x+2) \\
 &= (x-1)(2x-4)(x+2) \\
 \therefore \text{As we are given } 2x^3 - 2x^2 - 8x + 8 &= 0 \\
 \Rightarrow (x-1)(2x-4)(x+2) &= 0 \\
 \Rightarrow x = 1, x = 2 \text{ or } x = -2
 \end{aligned}$$

Checking: When $x = 1$ has already been proved valid

$$\text{When } x = 2, 2x^3 - 2x^2 - 8x + 8 = 2 \times 2^3 - 2 \times 2^2 - 8 \times 2 + 8 = 0 = \text{RHS } \checkmark$$

$$\text{When } x = -2, 2x^3 - 2x^2 - 8x + 8 = 2 \times (-2)^3 - 2 \times (-2)^2 - 8 \times (-2) + 8 = 0 = \text{RHS } \checkmark$$

Solutions Exercise Set 2.11 cont.

(d) $t^3 + 3t^2 - 6t - 6 = 2$

$$\therefore t^3 + 3t^2 - 6t - 8 = 0$$

Try $t = 1$ as a solution: when $t = 1$, LHS = $1^3 + 3 \times 1^2 - 6 \times 1 - 8 = -14 \neq$ RHS

$\therefore (t - 1)$ is not a factor

Try $t = -1$ as a solution: when $t = -1$, LHS = $(-1)^3 + 3 \times (-1)^2 - 6 \times (-1) - 8 = 0 =$ RHS

So $t = -1$ is a solution and $(t - 1)$ is a factor

$$(t + 1) \begin{array}{r} t^2 + 2t - 8 \\ \hline t^3 + 3t^2 - 6t - 8 \\ \underline{t^3 + t^2} \\ 2t^2 - 6t \\ \underline{2t^2 + 2t} \\ -8t - 8 \\ \underline{-8t - 8} \\ 0 \end{array}$$

$$\therefore t^3 + 3t^2 - 6t - 8 = (t + 1)(t^2 + 2t - 8)$$

$$= (t + 1)(t + 4)(t - 2)$$

$$\therefore \text{As we are given } t^3 + 3t^2 - 6t - 8 = 0$$

$$\Rightarrow (t + 1)(t + 4)(t - 2) = 0$$

$$\Rightarrow t = -1, t = -4 \text{ or } t = 2$$

Checking: When $t = -1$ has already been proved valid

$$\text{When } t = -4, t^3 + 3t^2 - 6t - 6 = (-4)^3 + 3 \times (-4)^2 - 6 \times (-4) - 6 = 2 = \text{RHS } \checkmark$$

See Note 1

$$\text{When } t = 2, t^3 + 3t^2 - 6t - 6 = 2^3 + 3 \times 2^2 - 6 \times 2 - 6 = 2 = \text{RHS } \checkmark$$

Notes

- Here I have checked by substituting in the **original** equation. This is a good idea in case an error has been made right back in the beginning.

Solutions Exercise Set 2.11 cont.

(e) $y^3 + 6 = 2y^2 + 5y$

$$\therefore y^3 - 2y^2 - 5y + 6 = 0$$

Try $y = 1$ as a solution: when $y = 1$, $\text{LHS} = 1^3 - 2 \times 1^2 - 5 \times 1 + 6 = 0 = \text{RHS}$ So $y = 1$ is a solution and $(y - 1)$ is a factor

$$(y-1) \begin{array}{r} y^2 - y - 6 \\ \hline y^3 - 2y^2 - 5y + 6 \\ \underline{y^3 - y^2} \\ -y^2 - 5y \\ \underline{-y^2 + y} \\ -6y + 6 \\ \underline{-6y + 6} \end{array}$$

$$\begin{aligned} \therefore y^3 - 2y^2 - 5y + 6 &= (y-1)(y^2 - y - 6) \\ &= (y-1)(y-3)(y+2) \end{aligned}$$

$$\therefore \text{As we are given } y^3 - 2y^2 - 5y + 6 = 0$$

$$\Rightarrow (y-1)(y-3)(y+2) = 0$$

$$\Rightarrow y = 1, y = 3 \text{ or } y = -2$$

Checking: When $y = 1$ has already been proved valid

When $y = 3$, $\text{LHS} = y^3 + 6 = 3^3 + 6 = 33$ and

$$\text{RHS} = 2y^2 + 5y = 2 \times 3^2 + 5 \times 3 = 33 = \text{LHS} \quad \checkmark$$

When $y = -2$, $\text{LHS} = y^3 + 6 = (-2)^3 + 6 = -2$ and

$$\text{RHS} = 2y^2 + 5y = 2 \times (-2)^2 + 5 \times (-2) = -2 = \text{RHS} \quad \checkmark$$

Solutions Exercise Set 2.11 cont.

2. (a) $P(x) = x^3 + 4x^2 - x - 4$

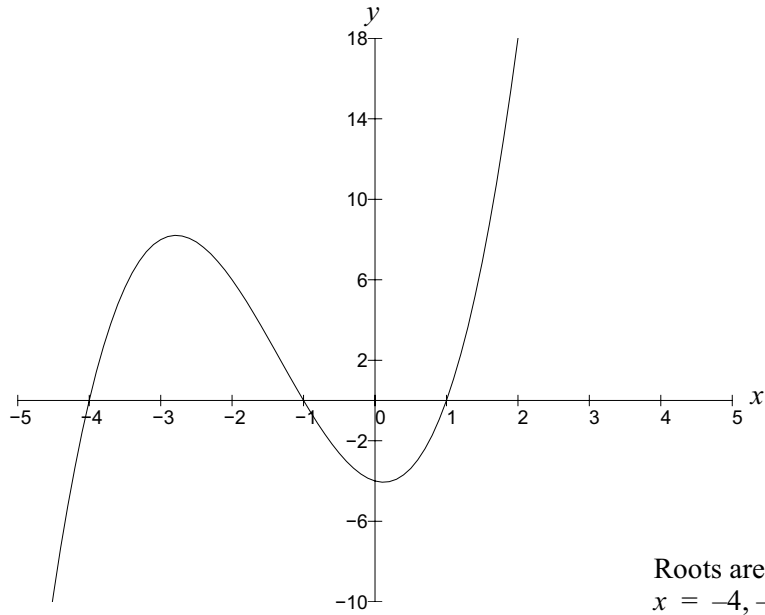

Roots are
 $x = -4, -1$ and 1

(b) $P(x) = 2x^3 - 2x^2 - 8x + 8$

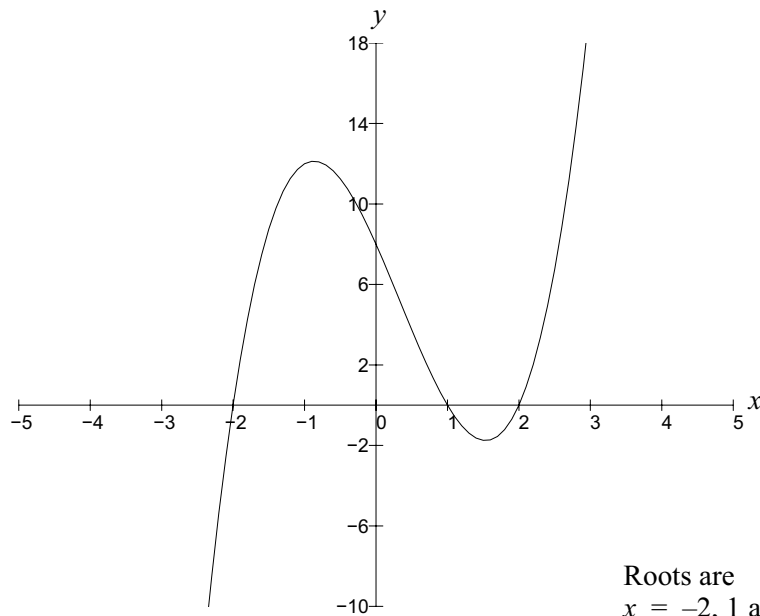

Roots are
 $x = -2, 1$ and 2

Solutions Exercise Set 2.11 cont.

(c) $P(x) = 3x^2 + 2x - 1$

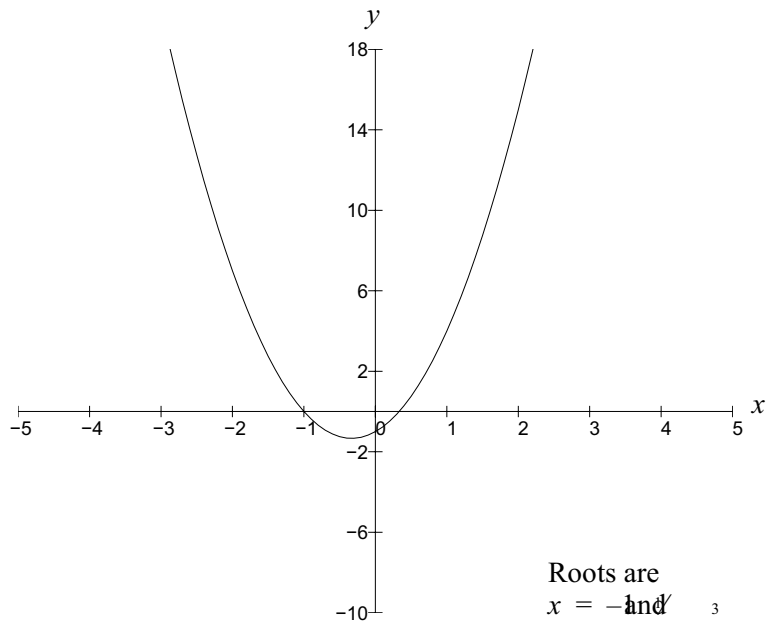

(d) $P(x) = x^3 + 2x^2 - x - 2$

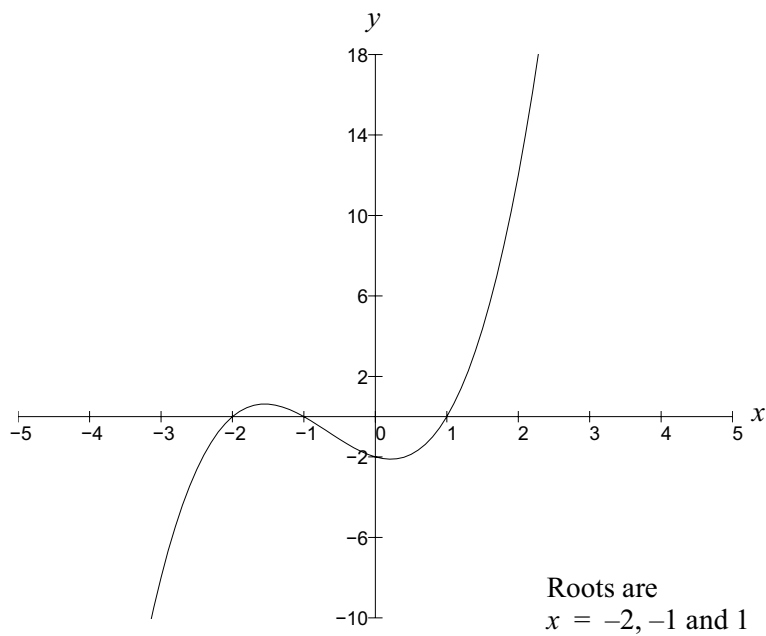

Solutions Exercise Set 2.12 page 2.34

1.

	Rational Fraction	Improper or proper	Not defined
(a) $\frac{x^2}{x-1}$	Yes	Improper	For $x = 1$
(b) $\frac{\sqrt{x}}{x-1}$	No		For $x \leq 0$ and $x = 1$
(c) $\frac{x}{x^2-5x+6} = \frac{x}{(x+3)(x-2)}$	Yes	Proper	For $x = 2$ and $x = 3$
(d) $\frac{x^2-1}{x(x-1)^2}$	Yes	Proper	For $x = 0$ and $x = 1$
(e) $\frac{7x+3}{x^3-2x^2-3x} = \frac{7x+3}{x(x+1)(x-3)}$	Yes	Proper	For $x = -1, x = 0$ and $x = 3$
(f) $\frac{x^3+3x-4}{x-2}$	Yes	Improper	For $x = 2$
(g) $\frac{\cos x}{x^2+x-1}$	No		

Solutions Exercise Set 2.13 page 2.36

1.

$$\frac{x^2+4x}{x+2} = (x+2) \begin{array}{r} x \\ x^2+4x \\ \hline x^2+2x \\ \hline 2x \end{array}$$

$$\therefore \frac{x^2+4x}{x+2} = x + \frac{2x}{x+2}$$

See Note 1

$$\text{Checking: } x + \frac{2x}{x+2} = \frac{x(x+2)+2x}{x+2} = \frac{x^2+2x+2x}{x+2} = \frac{x^2+4x}{x+2} \quad \checkmark$$

2.

$$\frac{x^3-2x+1}{x^2-4} = (x^2-4) \begin{array}{r} x \\ x^3-2x+1 \\ \hline x^3-4x \\ \hline 2x+1 \end{array}$$

$$\therefore \frac{x^3-2x+1}{x^2-4} = x + \frac{2x+1}{x^2-4}$$

$$\text{Checking: } x + \frac{2x+1}{x^2-4} = \frac{x(x^2-4)+2x+1}{x^2-4} = \frac{x^3-4x+2x+1}{x^2-4} = \frac{x^3-2x+1}{x^2-4} \quad \checkmark$$

3.

$$\frac{x^3-3x}{x^2-2x} = (x^2-2x) \begin{array}{r} x+2 \\ x^3+0x^2-3x \\ \hline x^3-2x^2 \\ \hline 2x^2-4x \\ \hline x \end{array}$$

$$\therefore \frac{x^3-3x}{x^2-2x} = x + 2 + \frac{x}{x^2-2x}$$

$$\text{Checking: } x + 2 + \frac{x}{x^2-2x} = \frac{x(x^2-2x)+2(x^2-2x)+x}{x^2-2x}$$

$$= \frac{x^3-2x^2+2x^2-4x+x}{x^2-2x} = \frac{x^3-3x}{x^2-2x} \quad \checkmark$$

Notes

1. The sums of proper rational functions are not unique. $\frac{x^2+4x}{x+2}$ also equals $x+2-\frac{4}{x+2}$.

Solutions Exercise Set 2.13 cont.

$$4. \quad \frac{7x^3 + 3}{x^3 - 2x^2 - 3x} = x^3 - 2x^2 - 3x \left[\begin{array}{r} 7x^3 + 0x^2 + 0x + 3 \\ \underline{7x^3 - 14x^2 - 21x} \\ 14x^2 + 21x + 3 \end{array} \right]$$

$$\therefore \frac{7x^3 + 3}{x^3 - 2x^2 - 3x} = 7 + \frac{14x^2 + 21x + 3}{x^3 - 2x^2 - 3x}$$

$$\text{Checking: } 7 + \frac{14x^2 + 21x + 3}{x^3 - 2x^2 - 3x} = \frac{7(x^3 - 2x^2 - 3x) + 14x^2 + 21x + 3}{x^3 - 2x^2 - 3x}$$

$$= \frac{7x^3 - 14x^2 - 21x + 14x^2 + 21x + 3}{x^3 - 2x^2 - 3x}$$

$$= \frac{7x^3 + 3}{x^3 - 2x^2 - 3x}$$

$$5. \quad \frac{x^2 - 8}{3x^2 - 12x + 6} = \frac{x^2 - 8}{3(x^2 - 4x + 2)} = \frac{1}{3} \left\{ \frac{x^2 - 8}{x^2 - 4x + 2} \right\}$$

$$\text{Now } \frac{x^2 - 8}{x^2 - 4x + 2} = (x^2 - 4x + 2) \left[\begin{array}{r} 1 \\ \underline{x^2 + 0x - 8} \\ x^2 - 4x + 2 \\ \underline{4x - 10} \end{array} \right]$$

$$= 1 + \frac{4x - 10}{x^2 - 4x + 2}$$

$$\therefore \frac{1}{3} \left\{ \frac{x^2 - 8}{x^2 - 4x + 2} \right\} = \frac{1}{3} \left\{ 1 + \frac{4x - 10}{x^2 - 4x + 2} \right\}$$

$$= \frac{1}{3} + \frac{4x - 10}{3x^2 - 12x + 6}$$

$$\text{Checking: } \frac{1}{3} + \frac{4x - 10}{3x^2 - 12x + 6} = \frac{(x^2 - 4x + 2) + 4x - 10}{3x^2 - 12x + 6}$$

$$= \frac{x^2 - 4x + 2 + 4x - 10}{3x^2 - 12x + 6} = \frac{x^2 - 8}{3x^2 - 12x + 6} \quad \checkmark$$

Solutions Exercise Set 2.14 page 2.46

$$1. \frac{3-x}{(2-x)(2x-1)} = \frac{P(x)}{Q(x)}$$

$$\text{Step 1: } Q(x) = (2-x)(2x-1)$$

{Product of two non-identical linear factors}

$$\text{Step 2: } \frac{3-x}{(2-x)(2x-1)} = \frac{A}{(2-x)} + \frac{B}{(2x-1)}$$

$$\begin{aligned} \text{Step 3: } \frac{3-x}{(2-x)(2x-1)} &= \frac{A(2x-1) + B(2-x)}{(2-x)(2x-1)} \\ &= \frac{2Ax - A + 2B - Bx}{(2-x)(2x-1)} \\ &= \frac{(2A - B)x + (-A + 2B)}{(2-x)(2x-1)} \end{aligned}$$

$$\begin{aligned} \text{Step 4: } \therefore -A + 2B &= 3 \quad \textcircled{1} \\ \text{and } 2A - B &= -1 \quad \textcircled{2} \end{aligned} \quad \left\{ \begin{array}{l} \text{Equating coefficients of power of } x \end{array} \right.$$

$$\text{Step 5: From } \textcircled{1}, A = 2B - 3 \text{ substituting in } \textcircled{2} \text{ gives } 2(2B - 3) - B = -1$$

$$\therefore 4B - 6 - B = -1 \quad \therefore 3B = 5 \quad \therefore B = \frac{5}{3} \Rightarrow A = 2 \times \frac{5}{3} - 3 = \frac{1}{3}$$

$$\begin{aligned} \text{Step 6: } \therefore \frac{3-x}{(2-x)(2x-1)} &= \frac{A}{(2-x)} + \frac{B}{(2x-1)} \\ &= \frac{1/3}{2-x} + \frac{5/3}{2x-1} \\ &= \frac{1}{6-3x} + \frac{5}{6x-3} \end{aligned}$$

$$\begin{aligned} \text{Step 7: Checking: } \frac{1}{6-3x} + \frac{5}{6x-3} &= \frac{1 \times (6x-3) + 5 \times (6-3x)}{(6-3x)(6x-3)} \\ &= \frac{6x-3+30-15x}{3(2-x) \times 3(2x-1)} \\ &= \frac{-9x+27}{9(2-x)(2x-1)} \\ &= \frac{-x+3}{(2-x)(2x-1)} \quad \checkmark \end{aligned}$$

Solutions Exercise Set 2.14 cont.

$$2. \frac{9x - 72}{x^3 - 3x^2 - 18x} = \frac{P(x)}{Q(x)}$$

$$\begin{aligned} \text{Step 1: } Q(x) &= x^3 - 3x^2 - 18x && \{\text{Product of three non-identical linear factors}\} \\ &= x(x^2 - 3x - 18) \\ &= x(x + 3)(x - 6) \end{aligned}$$

$$\text{Step 2: } \frac{9x - 72}{x^3 - 3x^2 - 18x} = \frac{A}{x} + \frac{B}{x + 3} + \frac{C}{x - 6}$$

$$\begin{aligned} \text{Step 3: } \frac{9x - 72}{x^3 - 3x^2 - 18x} &= \frac{A(x + 3)(x - 6) + Bx(x - 6) + Cx(x + 3)}{(x)(x + 3)(x - 6)} \\ &= \frac{A(x^2 - 3x - 18) + Bx^2 - 6Bx + Cx^2 + 3Cx}{(x)(x + 3)(x - 6)} \\ &= \frac{Ax^2 - 3Ax - 18A + Bx^2 - 6Bx + Cx^2 + 3Cx}{(x)(x + 3)(x - 6)} \\ &= \frac{(A + B + C)x^2 + (-3A - 6B + 3C)x + (-18A)}{(x)(x + 3)(x - 6)} \end{aligned}$$

Step 4: Equating coefficients of powers of x

$$\begin{aligned} \therefore A + B + C &= 0 \\ -3A - 6B + 3C &= 9 \\ -18A &= -72 \end{aligned}$$

Step 5: Solving (not shown here) yields $A = 4$; $B = \frac{-11}{3}$; $C = \frac{-1}{3}$

$$\text{Step 6: } \frac{9x - 72}{x^3 - 3x^2 - 18x} = \frac{4}{x} + \frac{-11/3}{x + 3} + \frac{-1/3}{x - 6} = \frac{4}{x} - \frac{11}{3(x + 3)} - \frac{1}{3(x - 6)}$$

Solutions Exercise Set 2.14 cont.

2. continued

Step 7: Checking: $\frac{4}{x} - \frac{11}{3(x+3)} - \frac{1}{3(x-6)} = \frac{4(3)(x+3)(3)(x-6) - 11(x)(3)(x-6) - 1(x)(3)(x+3)}{x \cdot 3 \cdot (x+3) \cdot 3 \cdot (x-6)}$
 (I have not found the L.C.D. here)

$$\begin{aligned} &= \frac{36(x+3)(x-6) - 33x(x-6) - 3x(x+3)}{9x(x+3)(x-6)} \\ &= \frac{36(x^2 - 3x - 18) - 33x^2 + 198x - 3x^2 - 9x}{9x(x+3)(x-6)} \\ &= \frac{36x^2 - 108x - 648 - 33x^2 + 198x - 3x^2 - 9x}{9x(x+3)(x-6)} \\ &= \frac{81x - 648}{9x(x+3)(x-6)} \\ &= \frac{9(9x - 72)}{9x(x+3)(x-6)} \\ &= \frac{9x - 72}{x(x+3)(x-6)} \quad \checkmark \end{aligned}$$

3. $\frac{x^2 - 3x + 12}{(2-x)(1+x^2)} = \frac{P(x)}{Q(x)}$

Step 1: $Q(x) = (2-x)(1+x^2)$ {Product of one linear factor and one quadratic factor}

Step 2: $\frac{x^2 - 3x + 12}{(2-x)(1+x^2)} \equiv \frac{A}{(2-x)} + \frac{Bx + C}{(1+x^2)}$

Step 3: $\frac{x^2 - 3x + 12}{(2-x)(1+x^2)} = \frac{A(1+x^2) + (Bx + C)(2-x)}{(2-x)(1+x^2)}$
 $= \frac{A + Ax^2 + 2Bx - Bx^2 + 2C - Cx}{(2-x)(1+x^2)}$
 $= \frac{(A - B)x^2 + (2B - C)x + (A + 2C)}{(2-x)(1+x^2)}$

Step 4: Equating coefficients of powers of x

$$\begin{aligned} A - B &= 1 \\ 2B - C &= -3 \\ A + 2C &= 12 \end{aligned}$$

Solutions Exercise Set 2.14 cont.

3. continued

Step 5: Solving (not shown here) yields $A = 2$; $B = 1$; $C = 5$

$$\text{Step 6: } \frac{x^2 - 3x + 12}{(2-x)(1+x^2)} = \frac{2}{(2-x)} = \frac{x+5}{(1+x^2)}$$

$$\begin{aligned} \text{Step 7: Checking } \frac{x^2 - 3x + 12}{(2-x)(1+x^2)} &= \frac{2}{(2-x)} = \frac{x+5}{(1+x^2)} \\ &= \frac{2 + 2x^2 + 2x - x^2 + 10 - 5x}{(2-x)(1+x^2)} \\ &= \frac{x^2 - 3x + 12}{(2-x)(1+x^2)} \quad \checkmark \end{aligned}$$

4. $\frac{x^3 - 2x^2 - x + 3}{x^2 - x - 6} = \frac{P(x)}{Q(x)}$ but degree of $Q(x)$ is less than that of $P(x)$ so we know that the rational function is improper and polynomial division is required.

$$\begin{array}{r} x^3 - 2x^2 - x + 3 \\ x^2 - x - 6 \overline{) } \\ \underline{x^3 + 2x^2 - x + 3} \\ - x^2 - 6x \\ \underline{3x^2 + 5x + 3} \\ - 3x - 18 \\ \underline{8x + 21} \\ 8x + 21 \end{array}$$

$$\therefore \frac{x^3 + 2x^2 - x + 3}{x^2 - x - 6} = (x + 3) + \frac{8x + 21}{x^2 - x - 6}$$

Step 1: $Q(x) = x^2 - x - 6 = (x - 3)(x + 2)$ {Product of two non-identical linear factors}

Step 2: $\frac{x^3 + 2x^2 - x + 3}{x^2 - x - 6} \equiv (x + 3) + \frac{A}{(x - 3)} + \frac{B}{(x + 2)}$ See Note 1

Notes

1. Don't forget the $(x + 3)$ term from the division stage.

Solutions Exercise Set 2.14 cont.

4. continued

$$\begin{aligned} \text{Step 3: } \frac{8x+21}{x^2-x-6} &= \frac{A(x+2)+B(x-3)}{(x-3)(x+2)} \\ &= \frac{Ax+2A+Bx-3B}{(x-3)(x+2)} \\ &= \frac{(A+B)x+(2A-3B)}{(x-3)(x+2)} \end{aligned}$$

Step 4: Equating coefficients of powers of x **from Step 3.**

See Note 1

$$\begin{aligned} A + B &= 8 \\ 2A - 3B &= 21 \end{aligned}$$

Step 5: Solving (not shown here) yields $A = 9$; $B = -1$

$$\text{Step 6: } \frac{8x+21}{x^2-x-6} = \frac{9}{(x-3)} + \frac{-1}{(x+2)}$$

See Note 2

$$\therefore \frac{x^3+2x^2-x+3}{x^2-x-6} = (x+3) + \frac{9}{(x-3)} - \frac{1}{(x+2)}$$

$$\begin{aligned} \text{Step 7: Checking } (x+3) + \frac{9}{(x-3)} - \frac{1}{(x+2)} &= \frac{(x+3)(x-3)(x+2) + 9 \times (x+2) - 1 \times (x-3)}{(x-3)(x+2)} \\ &= \frac{(x^2-9)(x+2) + 9x + 18 - x + 3}{(x-3)(x+2)} \\ &= \frac{x^3 + 2x^2 - 9x - 18 + 9x + 18 - x + 3}{(x-3)(x+2)} \\ &= \frac{x^3 + 2x^2 - x + 3}{(x-3)(x+2)} \quad \checkmark \end{aligned}$$

Notes

1. Remember that you are equating coefficients of powers of x from the **remainder**.
2. Remember the $(x + 3)$ term.

Solutions Exercise Set 2.14 cont.

$$5. \frac{9x}{(1+x)(1-2x)^2} = \frac{P(x)}{Q(x)}$$

$$\text{Step 1: } Q(x) = (1+x)(1-2x)^2 = (1+x)(1-2x)(1-2x) \\ \text{\{Product of two identical linear factors and one other linear factor\}}$$

$$\text{Step 2: } \frac{9x}{(1+x)(1-2x)^2} \equiv \frac{A}{(1+x)} + \frac{B}{(1-2x)} + \frac{C}{(1-2x)^2}$$

$$\text{Step 3: } \frac{9x}{(1+x)(1-2x)^2} = \frac{A(1-2x)^2 + B(1+x)(1-2x) + C(1+x)}{(1+x)(1-2x)^2} \quad \text{See Note 1} \\ = \frac{A(1-4x+4x^2) + B(1-2x+x-2x^2) + C + Cx}{(1+x)(1-2x)^2} \\ = \frac{A-4Ax+4Ax^2 + B-Bx^2 - Bx^2 + C + Cx}{(1+x)(1-2x)^2} \\ = \frac{(4A-2B)x^2 + (-4A-B+C)x + (A+B+C)}{(1+x)(1-2x)^2}$$

Step 4: Equating coefficients of powers of x

$$\begin{aligned} 4A - 2B &= 0 \\ -4A - B + C &= 9 \\ A + B + C &= 0 \end{aligned}$$

Step 5: Solving (not shown here) yields $A = -1$; $B = -2$; $C = 3$

$$\text{Step 6: } \frac{9x}{(1+x)(1-2x)^2} = \frac{-1}{(1+x)} + \frac{-2}{(1-2x)} + \frac{3}{(1-2x)^2}$$

$$\text{Step 7: Checking } \frac{-1}{(1+x)} + \frac{-2}{(1-2x)} + \frac{3}{(1-2x)^2} \\ = \frac{-1 \times (1-2x)^2 - 2 \times (1+x)(1-2x) + 3 \times (1+x)}{(1+x)(1-2x)^2} \\ = \frac{-1 + 4x - 4x^2 - (2+2x)(1-2x) + 3 + 3x}{(1+x)(1-2x)^2} \\ = \frac{-1 + 4x - 4x^2 - 2 + 4x - 2x + 4x^2 + 3 + 3x}{(1+x)(1-2x)^2} \\ = \frac{9x}{(1+x)(1-2x)^2} \quad \checkmark$$

Notes

1. Take care finding the **lowest** common denominator.

Solutions Exercise Set 2.14 cont.

$$6. \text{ (a) } \frac{1}{r(r+1)} = \frac{P(r)}{Q(r)}$$

$$\text{Step 1: } Q(r) = r(r+1)$$

{Product of two non-identical linear factors}

$$\text{Step 2: } \frac{1}{r(r+1)} \equiv \frac{A}{r} + \frac{B}{r+1}$$

$$\begin{aligned} \text{Step 3: } \frac{1}{r(r+1)} &\equiv \frac{A(r+1) + Br}{r \times (r+1)} \\ &= \frac{Ar + A + Br}{r(r+1)} \\ &= \frac{r(A+B) + A}{r(r+1)} \end{aligned}$$

$$\begin{aligned} \text{Step 4: } A + B &= 0 \\ A &= 1 \end{aligned}$$

Step 5: Solving (not shown here) yields $A = 1$; $B = -1$

$$\text{Step 6: } \frac{1}{r(r+1)} = \frac{1}{r} - \frac{1}{r+1}$$

$$\text{(b) } \frac{1}{r(r+1)} = \frac{1}{r} - \frac{1}{r+1}$$

$$\therefore S_n = \sum_{r=1}^n \frac{1}{r(r+1)} = \sum_{r=1}^n \frac{1}{r} - \frac{1}{r+1}$$

$$= \sum_{r=1}^n \frac{1}{r} - \sum_{r=1}^n \frac{1}{r+1}$$

$$= \left(\frac{1}{1} + \frac{1}{2} + \frac{1}{3} + \frac{1}{4} + \dots + \frac{1}{n} \right) - \left(\frac{1}{2} + \frac{1}{3} + \frac{1}{4} + \dots + \frac{1}{n} + \frac{1}{n+1} \right)$$

$$\therefore S_n = 1 - \frac{1}{n+1}$$

$$\text{As } n \rightarrow \infty, \frac{1}{n+1} \rightarrow 0 \therefore S_n \rightarrow 1 - 0$$

$$\therefore S_\infty = 1$$

Solutions Exercise Set 2.15 page 2.60

Examine the graphs for each of these problems and make sure that the algebra and geometry 'match'.

$$\begin{aligned}
 1. \quad & y = 2x + 4 \quad \text{①} \\
 & y = 8x - 2 \quad \text{②} \\
 & \therefore 2x + 4 = 8x - 2 \\
 & \therefore -6x = -6 \\
 & \therefore x = 1
 \end{aligned}$$

When $x = 1$, Equation ① gives $y = 2 \times 1 + 4 = 6$
 $\therefore x = 1, y = 6$ is the solution

Checking: Equation ① RHS = $2 \times 1 + 4 = 6 =$ LHS \checkmark
 Equation ② RHS = $8 \times 1 - 2 = 6 =$ LHS \checkmark

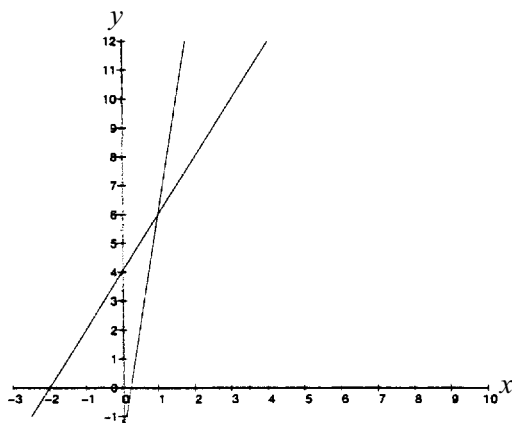

$$\begin{aligned}
 2. \quad & y = 2x - 4 \\
 & y = 2x + 6
 \end{aligned}$$

These lines have the same slope \therefore they will not have a point of intersection \Rightarrow no solution which satisfies both equations.

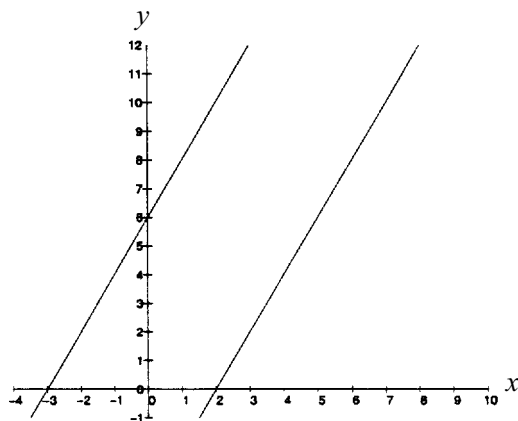

Solutions Exercise Set 2.15 cont.

$$3. \quad (x - 2)^2 + (y - 4)^2 = 16 \quad \text{①}$$

$$x = 3 \quad \text{②}$$

Substituting in Equation ① for x gives

$$(3 - 2)^2 + (y - 4)^2 = 16$$

$$\therefore 1 + (y - 4)^2 = 16$$

$$\therefore (y - 4)^2 = 15$$

$$\therefore y - 4 = \pm\sqrt{15}$$

$$\therefore y = \sqrt{15} + 4 \text{ or } y = -\sqrt{15} + 4$$

$$\therefore x = 3, y = \sqrt{15} + 4 \text{ and } x = 3, y = -\sqrt{15} + 4 \text{ are the solutions}$$

Checking: Equation ① when $x = 3$ and $y = -\sqrt{15} + 4$

$$\text{LHS} = (3 - 2)^2 + (-\sqrt{15} + 4 - 4)^2 = 1^2 + (-\sqrt{15})^2 = 16 = \text{RHS} \checkmark$$

Equation ② when $x = 3$ and $y = \sqrt{15} + 4$

$$\text{LHS} = (3 - 2)^2 + (\sqrt{15} + 4 - 4)^2 = 1^2 + (\sqrt{15})^2 = 16 = \text{RHS} \checkmark$$

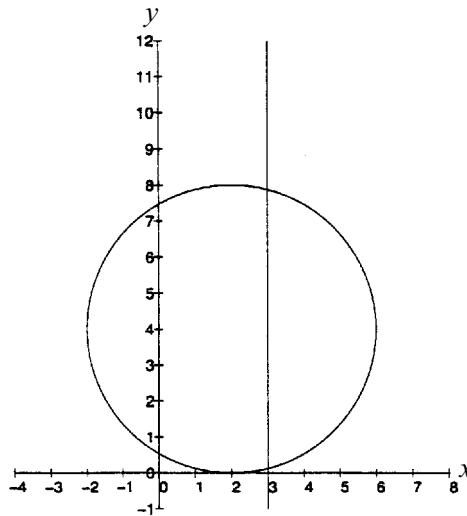

Solutions Exercise Set 2.15 cont.

$$4. \quad \begin{aligned} x^2 + y^2 &= 1 && \textcircled{1} \\ (x - 3)^2 + y^2 &= 4 && \textcircled{2} \end{aligned}$$

Subtracting equation $\textcircled{1}$ from equation $\textcircled{2}$ gives

$$\begin{aligned} (x - 3)^2 - x^2 &= 3 \\ \therefore x^2 - 6x + 9 - x^2 &= 3 \\ \therefore -6x &= -6 \\ \therefore x &= 1 \end{aligned}$$

Substituting in Equation $\textcircled{1}$ for x gives

$$\begin{aligned} 1^2 + y^2 &= 1 \\ y^2 &= 0 \\ y &= 0 \end{aligned}$$

There is only one solution, $x = 1, y = 0$

Checking: Equation $\textcircled{1}$, LHS = $1^2 + 0^2 = 1 = \text{RHS} \checkmark$
 Equation $\textcircled{2}$, LHS = $(1 - 3)^2 + 0^2 = (-2)^2 = 4 = \text{RHS} \checkmark$

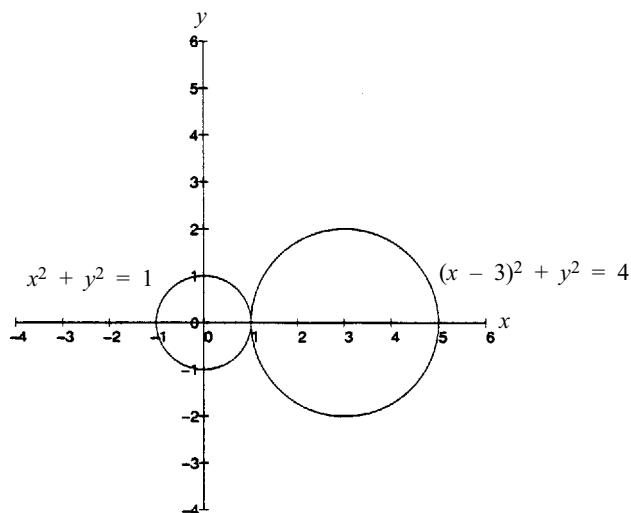

Solutions Exercise Set 2.15 cont.

$$5. \quad x^2 + y^2 - 4x + 2y + 4 = 0 \quad \text{①}$$

$$y = -3x \quad \text{②}$$

See Note 1

Substituting for y in Equation ① using $y = -3x$ from Equation ②

$$x^2 + (-3x)^2 - 4x + 2(-3x) + 4 = 0$$

$$x^2 + 9x^2 - 4x - 6x + 4 = 0$$

$$\therefore 10x^2 - 10x + 4 = 0$$

$$\therefore 5x^2 - 5x + 2 = 0$$

$$\therefore x = \frac{-(-5) \pm \sqrt{(-5)^2 - 4 \times 5 \times 2}}{2 \times 5}$$

$$= \frac{2 \pm \sqrt{-15}}{10}$$

This is impossible so there is no solution which satisfies both equations. The graph below shows that the line does not intersect with the circle.

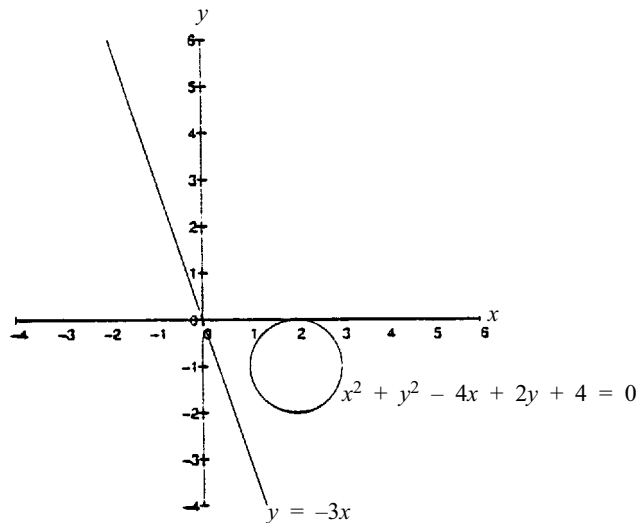

Notes

1. It would be difficult to visualise the graph of this equation if you had not used the **Hint** given in the question. By completing the square it becomes obvious that the circle is centred at $(2, -1)$ and has radius of 1. Getting an equation into a standard form that you can recognise is a very powerful tool.

Solutions Exercise Set 2.15 cont.

6. General form of a circle is

$$(x - h)^2 + (y - k)^2 = r^2$$

As (0, 0) is on the circle

$$(0 - h)^2 + (0 - k)^2 = r^2$$

$$\text{i.e. } h^2 + k^2 = r^2$$

As (0, 3) is on the circle

$$(0 - h)^2 + (3 - k)^2 = r^2$$

$$\text{i.e. } h^2 + 9 - 6k + k^2 = r^2$$

As (1, 0) is on the circle

$$(1 - h)^2 + (0 - k)^2 = r^2$$

$$\text{i.e. } 1 - 2h + h^2 + k^2 = r^2$$

Now we have three equations in h, k and r to solve simultaneously

$$h^2 + k^2 = r^2 \text{ _____ ①}$$

$$h^2 + 9 - 6k + k^2 = r^2 \text{ _____ ②}$$

$$h^2 + 1 - 2h + k^2 = r^2 \text{ _____ ③}$$

$$\text{From ①, } k^2 = r^2 - h^2 \text{ _____ ④}$$

Substituting in ③ for k^2 gives

$$h^2 + 1 - 2h + r^2 - h^2 = r^2$$

$$\therefore 1 - 2h = 0$$

$$\therefore h = \frac{1}{2}$$

Substituting in ② for h gives

$$\left(\frac{1}{2}\right)^2 + 9 - 6k + k^2 = r^2 \text{ _____ ⑤}$$

$$\text{From ④, } k^2 = r^2 - \left(\frac{1}{2}\right)^2$$

$$\therefore k^2 = r^2 - \left(\frac{1}{4}\right)$$

Substituting in ⑤ for k^2 gives

$$\frac{1}{4} + 9 - 6k + r^2 - \frac{1}{4} = r^2$$

$$\therefore 9 - 6k = 0$$

$$\therefore k = \frac{3}{2}$$

Substituting in ① for h and k gives

$$\left(\frac{1}{2}\right)^2 + \left(\frac{3}{2}\right)^2 = r^2$$

$$\therefore r^2 = \frac{1}{4} + \frac{9}{4} = \frac{10}{4} = \frac{5}{2}$$

 \therefore The circle has the equation

$$(x - \frac{1}{2})^2 + (y - \frac{3}{2})^2 = \frac{5}{2}$$

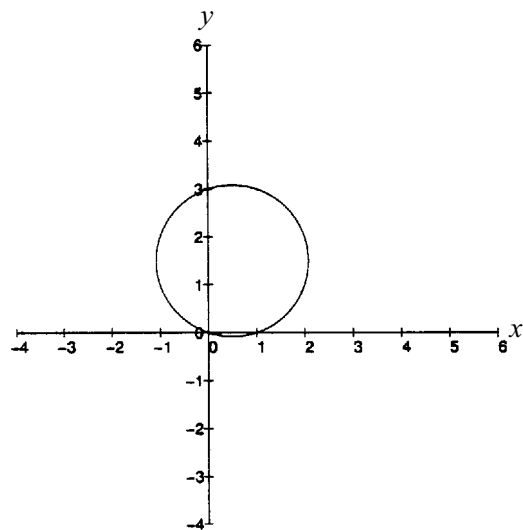

Solutions Exercise Set 2.15 cont.

6. continued

$$\text{Solving } (x - \frac{1}{2})^2 + (y - \frac{3}{2})^2 = \frac{5}{2} \text{ and } y = \ln x$$

looks complicated and indeed cannot be done algebraically. So the graphical method will be used. You could also do it numerically using guess and check.)

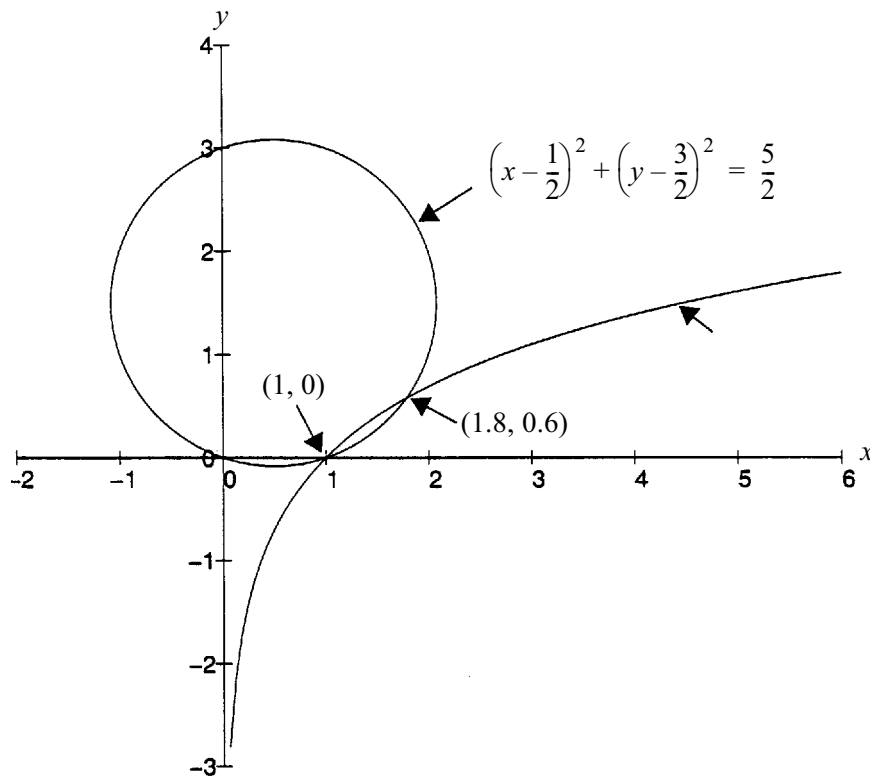

Zooming in on the points of intersection gives $x = 1$, $y = 0$ and $x \approx 1.8$, $y \approx 0.6$ as the solutions.

Remember to check the solutions by substituting in each of the original equations.'

Solutions Exercise Set 2.15 cont.

7. $y = e^{-x}$ _____ ①

$y = \frac{3}{1-x} + 2$ _____ ②

Using the **Hint** rewrite Equation ② as $y = \frac{-3}{x-1} + 2$ _____ ③

which is the equation to a hyperbola. This hyperbola is shown below.

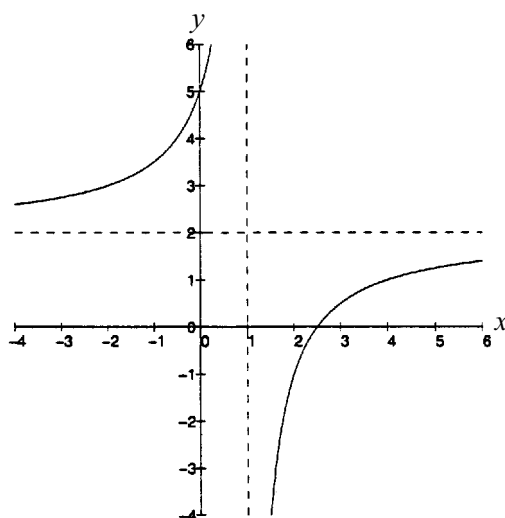

The graphical technique looks appropriate for solving the equations. Note that the hyperbola is restricted to the LH branch because it is defined for $x < 1$ only.

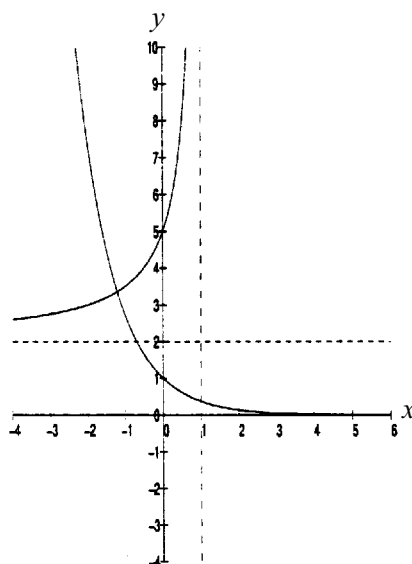

Zooming in on the point of intersection gives the solution $x \approx -1.2$, $y \approx 3.3$

Check this solution.

Solutions Exercise Set 2.15 cont.

8. $y = |2x|$ _____ ①

$y = \frac{2}{x}$ _____ ②

Rewrite Equation to give the equations for each branch of the graph of $y = |2x|$.

- The LH branch has equation $y_1 = -2x$ for $x \leq 0$
- The RH branch has equation $y_2 = 2x$ for $x \geq 0$

Then solve Case (i) $y_1 = -2x$ and $y = \frac{2}{x}$ for $x \leq 0$

and Case (ii) $y_2 = 2x$ and $y = \frac{2}{x}$ for $x \geq 0$

Case (i)

$$y_1 = -2x \quad \text{for } x \leq 0$$

$$y = \frac{2}{x}$$

$$\therefore -2x = \frac{2}{x} \quad \therefore x^2 = -1$$

This is impossible so there is no point of intersection of the hyperbola with the LH branch of $y = |2x|$

Case (ii)

$$y_2 = 2x \quad \text{for } x \geq 0$$

$$y = \frac{2}{x}$$

$$\therefore 2x = \frac{2}{x} \quad \therefore x^2 = 1 \quad \therefore x = +1 \text{ or } x = -1$$

But $y_2 = 2x$ is defined for $x \geq 0$, therefore there is only one solution and this occurs when $x = 1$ and $y = 2$.

Check this result with the graphs of $y = |2x|$ and $y = \frac{2}{x}$

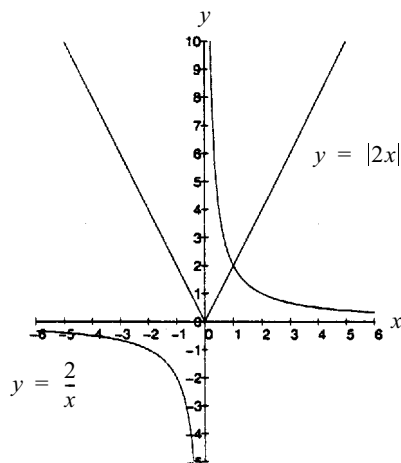

Solutions Exercise Set 2.15 cont.

9. Rewriting $(x + 1)(2 - x) = 5 \ln(1 + x)$ as two functions

$$y_1 = (x + 1)(2 - x) \text{ and}$$

$$y_2 = 5 \ln(1 + x)$$

when $y_1 = y_2$ the solution to the original equation is found.

$y_1 = (x + 1)(2 - x)$ is a parabola cutting the x -axis at $x = -1$ and $x = 2$ with a maximum turning point and axis of symmetry at $x = \frac{1}{2}$.

$y_2 = 5 \ln(1 + x)$ is a logarithmic curve.

The graphical solution method will be easiest.

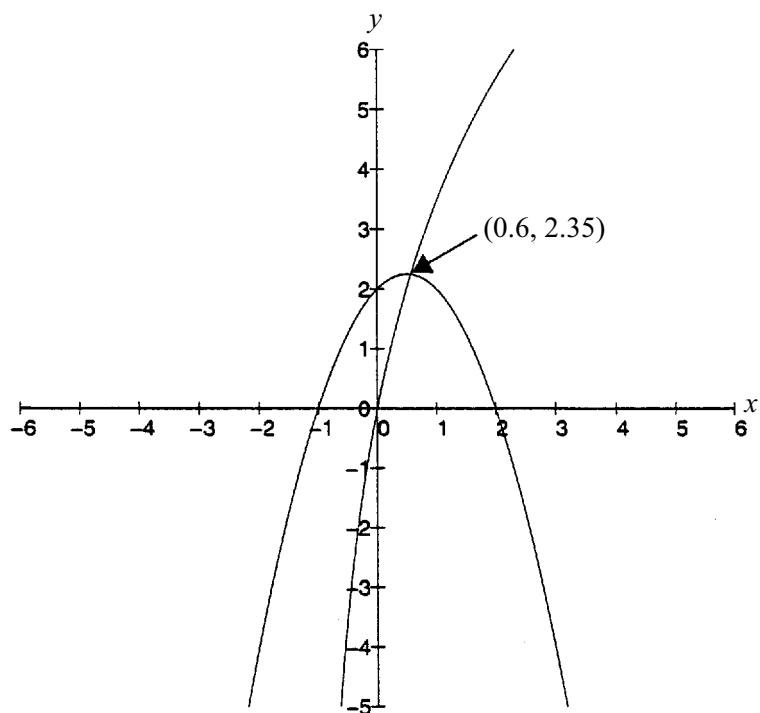

One solution only for y_1 and y_2 at $x = 0.6$ and $y = 2.35$ \therefore approximate solution to **original** equation is $x = 0.6$.

Checking: LHS of **original** equation = $(x + 1)(2 - x) = (0.6 + 1)(2 - 0.6) = 2.24$
 RHS of original equation = $5 \ln(1 + x) = 5 \ln(1 + 0.6) = 2.35$

You can improve the accuracy of the solution by zooming in further on the intersection point of y_1 and y_2

Solutions Exercise Set 2.16 page 2.64

1.	Graph	Function	One-to-one	Graph	Function	One-to-one
	(a)	Yes	Yes	(l)	Yes	Yes
	(b)	Yes	Yes	(m)	Yes	Yes
	(c)	Yes	Yes	(n)	Yes	Yes
	(d)	Yes	No	(o)	Yes	Yes
	(e)	Yes	Yes	(p)	Yes	Yes
	(f)	Yes	No	(q)	Yes	No
	(g)	Yes	Yes	(r)	Yes	Yes
	(h)	Yes	No	(s)	Yes	Yes
	(i)	Yes	Yes	(t)	No	
	(j)	Yes	Yes	(u)	Yes	Yes
	(k)	Yes	Yes	(v)	Yes	No

Graph	Inverse
(a)	(b)
(g)	(i)
(m)	(p)
(n)	(u)

Solutions Exercise Set 2.16 cont.

2. (i)

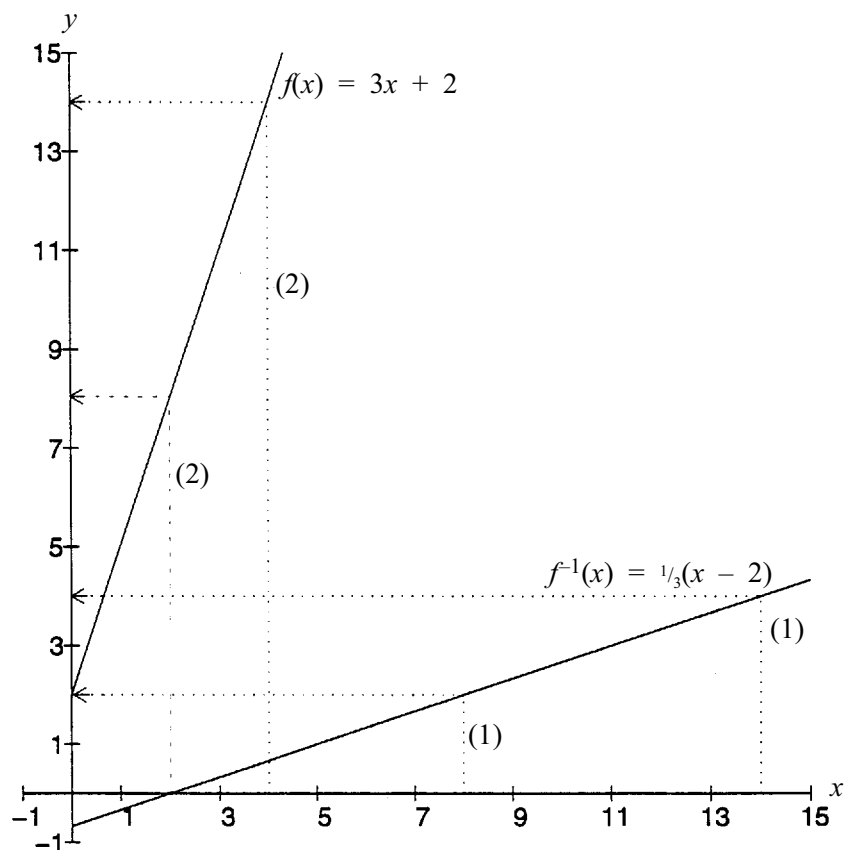

- (ii) Choose, say, $x = 8$, Step (1): $f^{-1}(8) = 2$ (reading from graph)
 Step (2): $f(f^{-1}(8)) = f(2) = 8$ (reading from graph)

Choose, say, $x = 14$, Step (1): $f^{-1}(14) = 4$ (reading from graph)
 Step (2): $f(f^{-1}(14)) = f(4) = 14$ (reading from graph)

For the two values chosen for x (and, in fact for any value of x)
 $f(f^{-1}(x)) = x$

- (iii) Following the same procedure but doing Step 2 first and then Step 1 shows that
 $f(f^{-1}(x)) = x$

Solutions Exercise Set 2.17 page 2.68

- If $f(x)$ is the height of a person who weighs x kg,
 $f^{-1}(x)$ is the weight of a person whose height is x cm See Note 1

So $f^{-1}(100)$ is the weight of a person who is 100 cm tall.
- $f(d)$ will not have an inverse as many different odometer readings will have the same number of litres in the tank depending on when it was last filled (i.e. $f(d)$ is not a one-to-one function).
 - The same number of people may be in the stores at say 12.10, 12.30, 12.50 etc. so $f(t)$ is not a one-to-one function and hence does not have an inverse.
 - There is a direct and unique relationship between the number of kilograms of ice and the volume it occupies. So $f(x)$ is a one-to-one function and its inverse exists.
 - Several first year students can have birthdays on the same day of the year. So $f(n)$ is not a one-to-one function and hence does not have an inverse.
 - The heavier the letter the more it costs to post so $f(w)$ is a one-to-one function and its inverse exists. [An assumption has been made here about the pricing policy for the mailing.]

If you had trouble with any of these questions try to work backwards e.g. in (iv). (If you were given a birthday could you uniquely identify the student? Obviously not! But in (iii) if you know the volume of ice you can determine exactly the mass of ice.

- There is a unique value of $f(x)$ for each x value i.e. there is a one-to-one mapping from x to $f(x)$ so $f(x)$ will have an inverse.

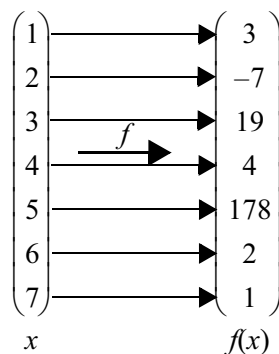

- Domain of $f(x)$ is the Set $D = \{1, 2, 3, 4, 5, 6, 7\}$ and the range of $f(x)$ is the Set $R = \{3, -7, 19, 4, 178, 2, 1\}$

The domain of $f^{-1}(x)$ will be the same as the range of $f(x)$
 i.e. $\{3, -7, 19, 4, 178, 2, 1\}$ and the range of $f(x)$ is $\{1, 2, 3, 4, 5, 6, 7\}$

Notes

- Technically $f(x)$ is the **mass** of the person. (Weight is a force)

Solutions Exercise Set 2.17 cont.

4. $f(x) = x^2 + 3x$

- (i) This is the equation of a parabola so there will be two values of x that give the same value of $f(x)$. [**Recall** that a parabola is symmetric about its axis of symmetry which in this case is at $x = \frac{-3}{2}$] e.g. $x = \frac{-1}{2}$ and $x = \frac{-5}{2}$ both give $f(x) = \frac{-5}{4}$
- (ii) Any domain which does not include the turning point will allow the inverse to be found. As the turning point will be on the axis of symmetry, this implies that any part of the domain $x \geq \frac{-3}{2}$ or any part of the domain $x \leq \frac{-3}{2}$ will be satisfactory.
- (iii) Choose say $\frac{-3}{2} \leq x \leq 2$

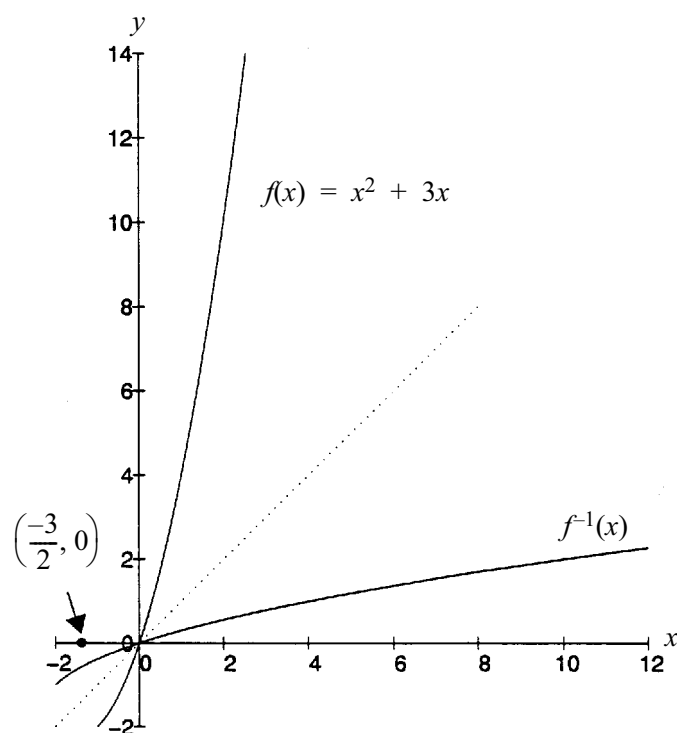

Solutions Exercise Set 2.17 cont.

5. $C(P) = 100 + 2P$

- (i) The domain should be restricted because making a negative number of articles is nonsense. So $P \geq 0$ is the domain. It also seems that there would be restrictions on the amount of inventory that can be held, the number of items the current machinery and labour can produce etc. thus there would be an upper limit also on P .

(ii) $C = 100 + 2P$

Reversing variables gives

$$P = 100 + 2C \quad [\text{Note: You are not rearranging the original equation}]$$

 \therefore Solving for C gives

$$C = \frac{P-100}{2}$$

$$\therefore C^{-1}(P) = \frac{1}{2}P - 50$$

- (iii) The number of articles that can be produced for a given amount of money.

6. (i) $f(x) = 2 + 3x$
i.e. $y = 2 + 3x$

Reversing variables: $x = 2 + 3y$
 $\therefore x - 2 = 3y$
 $\therefore y = \frac{x-2}{3}$
 i.e. $f^{-1}(x) = \frac{x-2}{3}$

Checking $f(f^{-1}(x)) = f\left(\frac{x-2}{3}\right)$
 $= 2 + 3\left(\frac{x-2}{3}\right)$
 $= 2 + x - 2$
 $= x \quad \checkmark$

(ii) $f(x) = 1 - x^2$ for $x \geq 0$
i.e. $y = 1 - x^2$

Reversing variables: $x = 1 - y^2$
 $\therefore y^2 = 1 - x$
 $\therefore y = \sqrt{1-x}$
 i.e. $f^{-1}(x) = \sqrt{1-x}$

{only concerned with positive root because of restriction on domain of $f(x)$ }

Checking $f^{-1}(f(x)) = f^{-1}(1 - x^2)$
 $= \sqrt{1 - (1 - x^2)}$
 $= \sqrt{1 - 1 + x^2}$
 $= x \quad \checkmark$

Solutions Exercise Set 2.17 cont.

$$(iii) \quad f(x) = 50e^{0.1x}$$

$$\text{i.e.} \quad y = 50e^{0.1x}$$

$$\text{Reversing variables:} \quad x = 50e^{0.1y}$$

$$\therefore \ln\left(\frac{x}{50}\right) = 0.1y$$

$$\therefore y = 10 \ln \frac{x}{50}$$

$$\text{i.e.} \quad f^{-1}(x) = 10 \ln\left(\frac{x}{50}\right)$$

Checking

$$\begin{aligned} f(f^{-1}(x)) &= f\left(10 \ln \frac{x}{50}\right) \\ &= 50e^{0.1 \times 10 \ln(x/50)} \\ &= 50e^{\ln(x/50)} \\ &= 50 \times \frac{x}{50} \\ &= x \quad \checkmark \end{aligned}$$

$$(iv) \quad f(x) = 2x^3 - 4$$

$$\text{i.e.} \quad y = 2x^3 - 4$$

[**Note:** Need to be careful that the inverse exists – a rough sketch helps]

$$\text{Reversing variables:} \quad x = 2y^3 - 4$$

$$\therefore x + 4 = 2y^3$$

$$\therefore y = \left(\frac{x+4}{2}\right)^{1/3}$$

$$\text{i.e.} \quad f^{-1}(x) = \left(\frac{x+4}{2}\right)^{1/3}$$

Checking

$$\begin{aligned} f^{-1}(f(x)) &= f^{-1}(2x^3 - 4) \\ &= \left(\frac{2x^3 - 4 + 4}{2}\right)^{1/3} \\ &= \left(\frac{2x^3}{2}\right)^{1/3} \\ &= (x^3)^{1/3} \\ &= x \quad \checkmark \end{aligned}$$

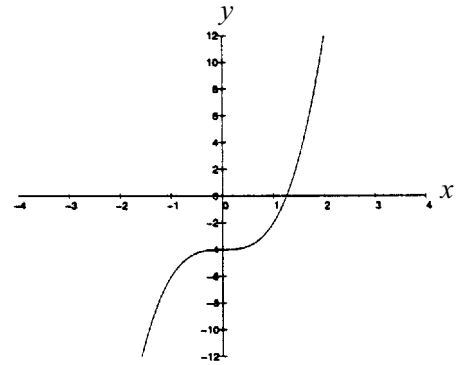

Solutions Exercise Set 2.17 cont.

$$(v) \quad f(x) = 2^{x^2-1} \quad \text{for } x \geq 0$$

$$\text{i.e.} \quad y = 2^{x^2-1}$$

Reversing variables:

$$x = 2^{y^2-1}$$

$$\therefore \log_2 x = \log_2 2^{y^2-1}$$

$$= y^2 - 1$$

$$\therefore 1 + \log_2 x = y^2$$

$$\therefore y = \sqrt{1 + \log_2 x}$$

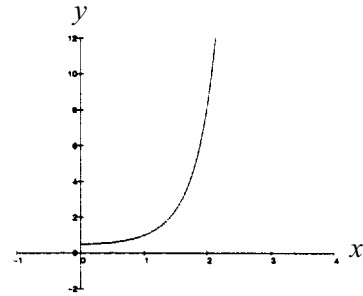

(only concerned with positive root)

Checking

$$f(f^{-1}(x)) = f(\sqrt{1 + \log_2 x})$$

$$= 2^{(\sqrt{1 + \log_2 x})^2 - 1}$$

$$= 2^{1 + \log_2 x - 1}$$

$$= 2^{\log_2 x}$$

$$= x \quad \checkmark$$

Solutions Exercise Set 2.18 page 2.73

1. (i)

	approaching $x = -1$ from the negative side			approaching $x = -1$ from the positive side		
x	-1.1	-1.01	-1.001	-0.999	-0.99	-0.9
$f(x) = x^3 - 2$	-0.79	-0.9799	-0.997999	-1.001999	-1.0199	-1.19

$$\lim_{x \rightarrow -1^-} (x^3 - 2) = -1 \quad ; \quad \lim_{x \rightarrow -1^+} (x^3 - 2) = -1$$

\therefore As $\lim_{x \rightarrow -1^-} f(x) = \lim_{x \rightarrow -1^+} f(x) = -1 \Rightarrow \lim_{x \rightarrow -1} f(x)$ exists and equals -1

(ii)

	approaching $x = 0$ from the negative side			approaching $x = 0$ from the positive side		
x	-0.2	-0.1	-0.001	0.01	0.1	0.2
$f(x) = \frac{x^2 + x}{x}$	0.8	0.9	0.999	1.01	1.1	1.2

$$\lim_{x \rightarrow 0^-} \left(\frac{x^2 + x}{x} \right) = 1 \quad ; \quad \lim_{x \rightarrow 0^+} \left(\frac{x^2 + x}{x} \right) = 1$$

\therefore As $\lim_{x \rightarrow 0^-} f(x) = \lim_{x \rightarrow 0^+} f(x) = 1 \Rightarrow \lim_{x \rightarrow 0} f(x)$ exists and equals 1

Note: This becomes obvious if $\frac{x^2 + x}{x}$ is simplified before the limit as $x \rightarrow 0$ is found.

$$\frac{x^2 + x}{x} = \frac{x^2}{x} + \frac{x}{x} = x + 1$$

$$\therefore \lim_{x \rightarrow 0} x + 1 = 1$$

Solutions Exercise Set 2.18 cont.

(iii)

	approaching $x = -3$ from the positive side			approaching $x = -3$ from the negative side		
x	-2.5	-2.9	-2.99	-3.01	-3.1	-3.5
$f(x) = \frac{x^2 - 9}{x + 3}$	-5.5	-5.9	-5.99	-6.01	-6.1	-6.5

$$\lim_{x \rightarrow -3^+} \frac{x^2 - 9}{x + 3} = -6 \quad ; \quad \lim_{x \rightarrow -3^-} \frac{x^2 - 9}{x + 3} = -6$$

\therefore As $\lim_{x \rightarrow -3^+} f(x) = \lim_{x \rightarrow -3^-} f(x) = -6 \Rightarrow \lim_{x \rightarrow -3} f(x)$ exists and equals -6

Note: This becomes obvious if $\frac{x^2 - 9}{x + 3}$ is simplified before the limit as $x \rightarrow -3$ is found.

$$\frac{x^2 - 9}{x + 3} = \frac{(x - 3)(x + 3)}{(x + 3)} = x - 3$$

$$\therefore \lim_{x \rightarrow -3} x - 3 = -6$$

(iv)

	approaching $x = 0$ from the negative side			approaching $x = 0$ from the positive side		
x See Note 1	-0.2	-0.1	-0.01	0.01	0.1	0.2
$f(x) = \frac{\tan x}{x}$	1.0135502	1.0033467	1.0000333	1.0000333	1.0033467	1.0135502

$$\lim_{x \rightarrow 0^-} \left(\frac{\tan x}{x} \right) = 1 \quad ; \quad \lim_{x \rightarrow 0^+} \left(\frac{\tan x}{x} \right) = 1$$

\therefore As $\lim_{x \rightarrow 0^-} f(x) = \lim_{x \rightarrow 0^+} f(x) = 1 \Rightarrow \lim_{x \rightarrow 0} f(x)$ exists and equals 1

This is an interesting and important example where the function is not defined at $x = 0$ but the limit does exist at $x = 0$.

Notes

1. Because $f(x)$ is a mixture of a trigonometric function and an algebraic function x **must** be in radians.

Solutions Exercise Set 2.18 cont.

2. (i) • $\lim_{x \rightarrow c} f(x)$ exists as $\lim_{x \rightarrow c^+} f(x) = \lim_{x \rightarrow c^-} f(x)$
- But $f(x)$ is not continuous at $x = c$ because $f(c) \neq \lim_{x \rightarrow c} f(x)$
- (ii) • $\lim_{x \rightarrow c} f(x)$ does not exist as $\lim_{x \rightarrow c^+} f(x) \neq \lim_{x \rightarrow c^-} f(x)$
- Because the $\lim_{x \rightarrow c} f(x)$ does not exist, $f(x)$ is not continuous at $x = c$
- (iii) • $\lim_{x \rightarrow c} f(x)$ exists as $\lim_{x \rightarrow c^+} f(x) = \lim_{x \rightarrow c^-} f(x)$
- Because the $\lim_{x \rightarrow c} f(x)$ exists and equals $f(c)$, $f(x)$ is continuous at $x = c$
- (iv) • $\lim_{x \rightarrow c} f(x)$ does not exist as $\lim_{x \rightarrow c^+} f(x) \neq \lim_{x \rightarrow c^-} f(x)$
- Because the $\lim_{x \rightarrow c} f(x)$ does not exist, $f(x)$ is not continuous at $x = c$

Note: This is the graph of the ‘greatest integer less than x ’ function. The symbol used is $[x]$.

So for $y = [x]$ some coordinates are $(3.2, 3), (3.7, 3), (-2.45, -3), (-4, -5)$

$$3. (i) f(x) = \begin{cases} 2x + 1 & \text{if } x \leq 0 \\ 2x & \text{if } x > 0 \end{cases} \quad c = 0$$

$$\lim_{x \rightarrow 0^+} f(x) = \lim_{x \rightarrow 0^+} 2x = 0 \quad \text{and} \quad \lim_{x \rightarrow 0^-} f(x) = \lim_{x \rightarrow 0^-} (2x + 1) = 1 \neq \lim_{x \rightarrow 0} f(x)$$

\therefore As $\lim_{x \rightarrow 0} f(x)$ does not exist $\Rightarrow f(x)$ is not continuous at $x = 0$

$$(ii) f(x) = \begin{cases} 3x - 1 & \text{if } x < 1 \\ 2 & \text{if } x = 1 \\ 2x & \text{if } x > 1 \end{cases} \quad c = 1$$

$$\lim_{x \rightarrow 1^+} f(x) = \lim_{x \rightarrow 1^+} 2x = 2 \quad \text{and} \quad \lim_{x \rightarrow 1^-} f(x) = \lim_{x \rightarrow 1^-} (3x - 1) = 2$$

\therefore As $\lim_{x \rightarrow 1^+} f(x) = \lim_{x \rightarrow 1^-} f(x) = 2 \Rightarrow \lim_{x \rightarrow 1} f(x)$ exists and equals 2

Now $f(1) = 2 \therefore$ As $\lim_{x \rightarrow 1} f(x) = f(1) = 2 \Rightarrow f(x)$ is continuous as $x = 1$

Solutions Exercise Set 2.18 cont.

3. continued

$$(iii) f(x) = \begin{cases} x^2 + 4 & \text{if } x < -1 \\ 2 & \text{if } x = -1 \\ -3x + 2 & \text{if } x > -1 \end{cases} \quad c = -1$$

$$\lim_{x \rightarrow -1^+} f(x) = \lim_{x \rightarrow -1^+} -3x + 2 = 5 \quad \text{and} \quad \lim_{x \rightarrow -1^-} f(x) = \lim_{x \rightarrow -1^-} x^2 + 4 = 5$$

$$\therefore \text{As } \lim_{x \rightarrow -1^+} f(x) = \lim_{x \rightarrow -1^-} f(x) = 5 \Rightarrow \lim_{x \rightarrow -1} f(x) \text{ exists and equals } 5$$

$$\text{Now } f(-1) = 2 \therefore \text{As } \lim_{x \rightarrow -1} f(x) \neq f(-1) \Rightarrow f(x) \text{ is not continuous as } x = -1$$

If you have trouble with any of these solutions draw the graphs so you can see clearly what is happening at $x = c$. You can also use the graphs to validate your answers.

$$4. f(x) = \begin{cases} 2x + 1 & \text{for } 0 \leq x \leq 2 \\ 7 - x & \text{for } 2 < x < 4 \\ x & \text{for } 4 \leq x \leq 5 \end{cases}$$

The particular values of x where ‘something interesting’ is happening is where the different functions come together to define $f(x)$ i.e. at $x = 2$ and $x = 4$.

Consider $x = 2$

$$\lim_{x \rightarrow 2^+} f(x) = \lim_{x \rightarrow 2^+} 7 - x = 5 \quad \text{and} \quad \lim_{x \rightarrow 2^-} f(x) = \lim_{x \rightarrow 2^-} 2x + 1 = 5 \quad \therefore \lim_{x \rightarrow 2} f(x) \text{ exists.}$$

$$\text{Now } f(2) = 2x + 1 \text{ when } x = 2 \text{ i.e. } f(2) = 2 \times 2 + 1 = 5$$

So $f(x)$ is continuous at $x = 2$ Consider $x = 4$

$$\lim_{x \rightarrow 4^+} f(x) = \lim_{x \rightarrow 4^+} x = 4 \quad \text{and} \quad \lim_{x \rightarrow 4^-} f(x) = \lim_{x \rightarrow 4^-} 7 - x = 3 \quad \therefore \lim_{x \rightarrow 4} f(x) \text{ does not exist} \therefore f(x) \text{ is not continuous at } x = 4$$

Solutions Exercise Set 2.18 cont.

In conclusion $f(x)$ is defined for all values of $0 \leq x \leq 6$ and is continuous for all such values except $x = 4$. The graph of $f(x)$ verifies this conclusion.

